



Data Sheet



MOVIDRIVE[®] MDX60B/61B/62B, MOVIDRIVE[®] MDR60A/61B
MOVIDRIVE[®] compact, MOVIDRIVE[®] A
Information regarding UL





Content

1	MOVIDRIVE® MDX60B/61B	4
1.1	Information regarding UL	4
1.2	Wiring diagram for basic unit	9
2	MOVIDRIVE® MDR60A/61B and MDX62B	12
2.1	Information regarding UL	12
2.2	Wiring diagrams	15
3	MOVIDRIVE® compact	18
3.1	Information Regarding UL	18
3.2	Wiring diagram for basic unit	20
4	MOVIDRIVE® A	22
4.1	Information Regarding UL	22
4.2	Wiring diagram for basic unit	24



1 MOVIDRIVE® MDX60B/61B

1.1 Information regarding UL

1.1.1 Field wiring power terminals

- MOVIDRIVE® MDX60B/61B 0005 – 0300: Use 60/75 °C copper wire only.
MOVIDRIVE® MDX60B/61B 0370 – 2500: Use 75 °C copper wire only.
- Tighten terminals to in-lbs (Nm) as follows:

Series	Size	in-lbs	Nm
MOVIDRIVE® MDX 60B/61B	0XS, 0S, 0L	5	0.6
	1, 2S	5	0.6
	2	13	1.5
	3	31	3.5
	4, 5	120	14
	6	180	20
	7	620	70

1.1.2 Short circuit current rating

Suitable for use on a circuit capable of delivering not more than

- 200,000 rms symmetrical amperes when protected by fuses and circuit breakers as described in the tables below.
- 65,000 rms symmetrical amperes when protected by ABB and Rockwell Type E Combination Motor controllers as described in the tables below.
- MOVIDRIVE® MDX60B/61B 0005 - 2500 (400 V units only).
Max. voltage is limited to 500 V.
- MOVIDRIVE® MDX60B/61B 0015 - 0300 (230 V units only).
Max. voltage is limited to 240 V.



1.1.3 Branch circuit protection

Integral solid state short circuit protection does not provide branch circuit protection. Branch circuit protection must be provided in accordance with the National Electrical Code and any additional local codes.

AC 400/500 V
units

Three Phase 380 V – 500 V Voltage Range				
Model	SCCR: 200 kA/ 500 V when protected by: Non Semiconductor Fuses (currents are maximum values)	SCCR: 200 kA/ 500 V when protected by Inverse-Time Circuit Breaker	SCCR: 65 kA/ 480 V: when protected by ¹⁾ : Type E Combination Motor Controller	SCCR: 65 kA/ 460 V when protected by:
MOVIDRIVE MODEL, 0005 (Size 0S)	15 A / 600 V	25 A max / 500 V Min	ABB, Model MS132-2.5 Rated 480 V, 1 HP	Rockwell Automation Model 140M-C2E-B25, Rated 460 V, 1.5 HP
MOVIDRIVE MODEL, 0008 (Size 0S)	15 A / 600 V	25 A max / 500 V Min	ABB, Model MS132-4.0 Rated 480 V, 2 HP	Rockwell Automation Model 140M-C2E-B40, Rated 460 V, 3 HP
MOVIDRIVE MODEL, 0011 (Size 0M)	15 A / 600 V	25 A max / 500 V Min	ABB, Model MS132-4.0 Rated 480 V, 2 HP	Rockwell Automation Model 140M-C2E-B40, Rated 460 V, 3 HP
MOVIDRIVE MODEL, 0014 (Size 0M)	15 A / 600 V	25 A max / 500 V Min	ABB, Model MS132-6.3 Rated 480 V, 3 HP	Rockwell Automation Model 140M-C2E-B63, Rated 460 V, 5 HP
MOVIDRIVE MODEL, 0015 (Size 1)	35 A / 600 V	25 A max / 500 V Min	ABB, Model MS132-6.3 Rated 480 V, 3 HP	Rockwell Automation Model 140M-C2E-B63, Rated 460 V, 5 HP
MOVIDRIVE MODEL, 0022 (Size 1)	35 A / 600 V	25 A max / 500 V Min	ABB, Model MS132-6.3 Rated 480 V, 3 HP	Rockwell Automation Model 140M-C2E-B63, Rated 460 V, 5 HP
MOVIDRIVE MODEL, 0030 (Size 1)	35 A / 600 V	25 A max / 500 V Min	ABB, Model MS132-10 Rated 480 V, 5 HP	Rockwell Automation Model 140M-C2E-C10, Rated 460 V, 7.5 HP
MOVIDRIVE MODEL, 0040 (Size 1)	35 A / 600 V	25 A max / 500 V Min	ABB, Model MS132-12 Rated 480 V, 7.5 HP	Rockwell Automation Model 140M-D8E-C16, Rated 460 V, 10 HP
MOVIDRIVE MODEL, 0055 (Size 2S)	60 A / 600 V	25 A max / 500 V Min	ABB, Model MS132-16 Rated 480 V, 10 HP	Rockwell Automation Model 140M-D8E-C16, Rated 460 V, 10 HP
MOVIDRIVE MODEL, 0075 (Size 2S)	60 A / 600 V	25 A max / 500 V Min	ABB, Model MS132-20 Rated 480 V, 10 HP	Rockwell Automation Model 140M- D8E-C20, Rated 460 V, 15 HP
MOVIDRIVE MODEL, 0110 (Size 2)	110 A / 600 V	-	ABB, Model MS132-32 Rated 480 V, 20 HP	Rockwell Automation Model 140M-F8E-C32, Rated 460 V, 25 HP
MOVIDRIVE MODEL, 0150 (Size 3)	175 A / 600 V	90 A max / 500 V Min	ABB, Model MS450-40E Rated 480 V, 30 HP	Rockwell Automation Model 140M-F8E-C45, Rated 460 V, 30 HP
MOVIDRIVE MODEL, 0220 (Size 3)	175 A / 600 V	90 A max / 500 V Min	ABB, Model MS495-63E Rated 480 V, 50 HP	-
MOVIDRIVE MODEL, 0300 (Size 3)	225 A / 600 V	90 A max / 500 V Min	ABB, Model MS495-75E Rated 480 V, 60 HP	-
MOVIDRIVE MODEL, 0370 (Size 4)	350 A / 600 V	175 A max / 500 V Min	ABB, Model MS495-90E Rated 480 V, 75 HP	-
MOVIDRIVE MODEL, 0450 (Size 4)	350 A / 600 V	175 A max / 500 V Min	-	-
MOVIDRIVE MODEL, 0550 (Size 5)	500 A / 600 V	175 A max / 500 V Min	-	-



MOVIDRIVE® MDX60B/61B

Information regarding UL

Three Phase 380 V – 500 V Voltage Range				
Model	SCCR: 200 kA/ 500 V when protected by: Non Semiconductor Fuses (currents are maximum values)	SCCR: 200 kA/ 500 V when protected by Inverse-Time Circuit Breaker	SCCR: 65 kA/ 480 V: when protected by ¹⁾ : Type E Combination Motor Controller	SCCR: 65 kA/ 460 V when protected by:
MOVIDRIVE MODEL, 0750 (Size 5)	500 A / 600 V	175 A max / 500 V Min	-	-
MOVIDRIVE MODEL, 0900 (Size 6)	250 A / 600 V	300 A max / 500 V Min	-	-
MOVIDRIVE MODEL, 1100 (Size 6)	300 A / 600 V	300 A max / 500 V Min	-	-
MOVIDRIVE MODEL, 1320 (Size6)	400 A / 600 V	300 A max / 500 V Min	-	-
MOVIDRIVE MODEL, 1600 (Size 7)	400 A / 600 V	600 A max / 500 V Min	-	-
MOVIDRIVE MODEL, 2000 (Size 7)	500 A / 600 V	600 A max / 500 V Min	-	-
MOVIDRIVE MODEL, 2500 (Size 7)	600 A / 600 V	600 A max / 500 V Min	-	-

1) Drives employing Type E Combination Motor Controller model MS132-12, -16, -20, -25, -32 must be installed with Current Limiter Series S803W-SCLxxx-SR manufactured by ABB, otherwise SCCR rated 30kA/ 480 Vrms.



AC 230 V units

Three Phase 200 V – 240 V Voltage Range				
Model	SCCR: 200 kA/ 240 V when protected by: Non Semiconductor Fuses (currents are maximum values)	SCCR: 200 kA/ 240 V when protected by: Inverse-Time Circuit Breaker	SCCR: 65 kA/ 240 V when protected by:¹⁾ Type E Combination Motor Controller	SCCR: 65 kA/ 240 V when protected by:
MOVIDRIVE MODEL, 0015 (Size 1)	30 A / 250 V	25 A max / 240 V Min	ABB, Model MS132-10 Rated 480 V, 5 HP	Rockwell Automation Model 140M-C2E-C10, Rated 460 V, 7.5 HP
MOVIDRIVE MODEL, 0022 (Size 1)	30 A / 250 V	25 A max / 240 V Min	ABB, Model MS132-10 Rated 480 V, 5 HP	Rockwell Automation Model 140M-C2E-C10, Rated 460 V, 7.5 HP
MOVIDRIVE MODEL, 0037 (Size 1)	30 A / 250 V	25 A max / 240 V Min	ABB, Model MS132-20 Rated 480 V, 10 HP	Rockwell Automation Model 140M-D8E-C20, Rated 460 V, 15 HP
MOVIDRIVE MODEL, 0055 (Size 2)	110 A / 250 V	40 A max / 240 V Min	ABB, Model MS132-25 Rated 480 V, 15 HP	Rockwell Automation Model 140M-F8E-C25, Rated 460 V, 20 HP
MOVIDRIVE MODEL, 0075 (Size 2)	110 A / 250 V	40 A max / 240 V Min	ABB, Model MS450-40E Rated 480 V, 30 HP	Rockwell Automation Model 140M-F8E-C45, Rated 460 V, 30 HP
MOVIDRIVE MODEL, 0110 (Size 3)	175 A / 250 V	90 A max / 240 V Min	ABB, Model MS450-50E Rated 480 V, 40 HP	-
MOVIDRIVE MODEL, 0150 (Size 3)	225 A / 250 V	90 A max / 240 V Min	ABB, Model MS495-63E Rated 480 V, 50 HP	-
MOVIDRIVE MODEL, 0220 (Size 4)	350 A / 250 V	175 A max / 240 V Min	ABB, Model MS495-90E Rated 480 V, 75 HP	-
MOVIDRIVE MODEL, 0300 (Size 4)	350 A / 250 V	175 A max / 240 V Min	-	-

1) Drives employing Type E Combination Motor Controller model MS132-12, -16, -20, -25, -32 must be installed with Current Limiter Series S803W-SCLxxx-SR manufactured by ABB, otherwise SCCR rated 30kA/ 480 Vrms.



1.1.4 Motor overload protection

The units are provided with load and speed-sensitive overload protection and thermal memory retention upon shutdown or power loss.

The trip current is adjusted to 150 % of the rated motor current.

1.1.5 Ambient temperature

The units are suitable for an ambient temperature of 40 °C, max. 60 °C with derated output current.

To determine output current rating at higher than 40 °C, the output current should be derated 2.5 % per °C between 40 °C and 50 °C, and 3 % per °C between 50 °C and 60 °C.



INFORMATION

- Use only tested units with a **limited output voltage** ($V_{\max} = \text{DC } 30 \text{ V}$) and **limited output current** ($I_{\max} = 8 \text{ A}$) as an **external DC 24 V voltage source**.
- **UL certification does not apply to operation in voltage supply systems with a non-grounded star point (IT systems).**



1.2 Wiring diagram for basic unit

1.2.1 Power section (sizes 0 – 6) and brake

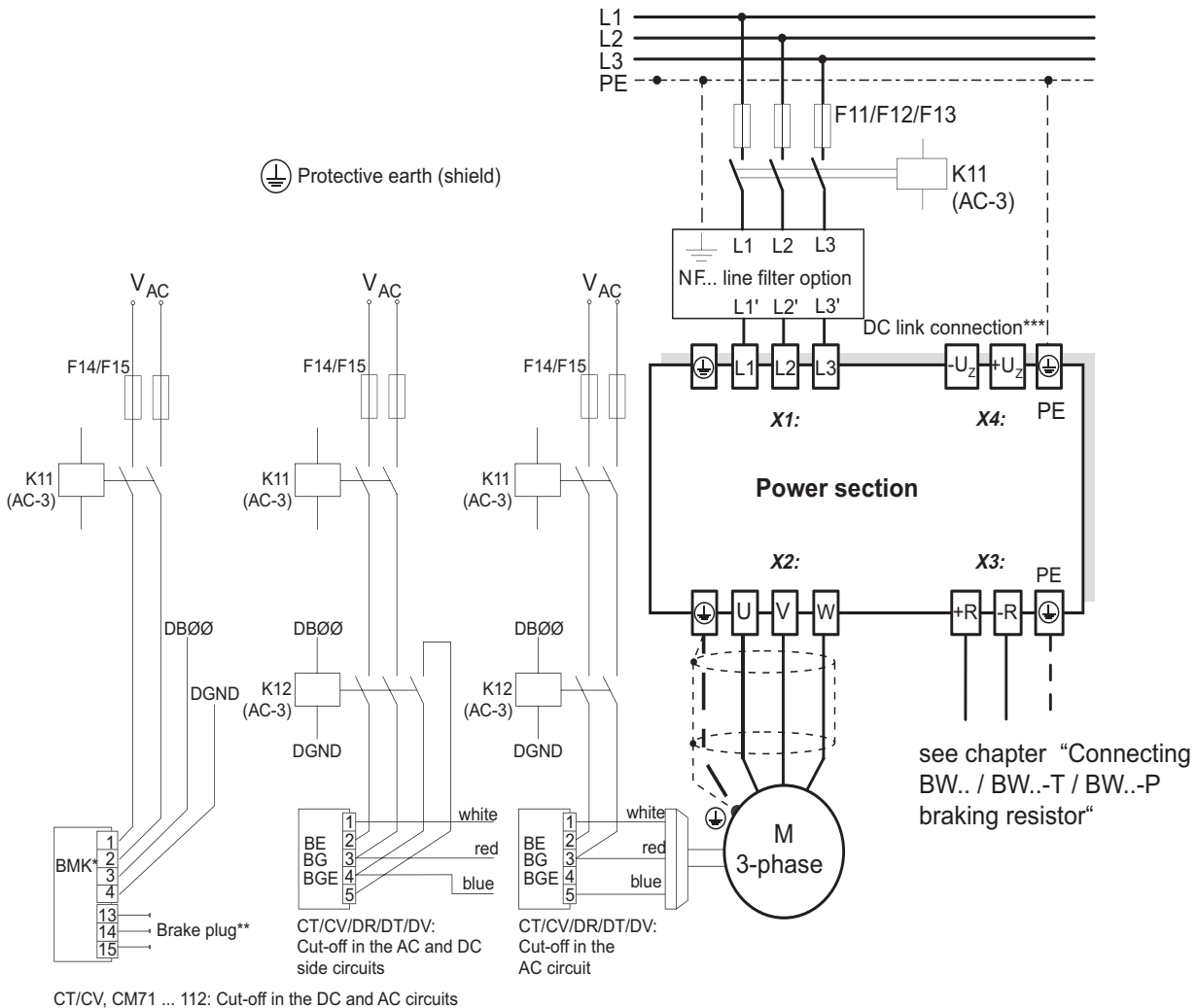

1805559691

* K12 is not required when K11 is used

** **You must adhere to the connection sequence of the brake connector.** Incorrect connection will cause irreparable damage to the brake. **Read the operating instructions for the motors** when connecting the brake using the terminal box.

*** With sizes 1, 2 and 2S, there is no PE connection next to the supply system connection terminals and motor connection terminals (X1, X2). In this case, use the PE terminal next to the DC link connection (X4).



INFORMATION

- Connect the brake rectifier using a separate supply system lead.
- **Supply via the motor voltage is not permitted!**

Always switch off the brake on the DC and AC sides with:

- all hoist applications,
- Drives that require a rapid brake response time
- CFC and SERVO operating modes



MOVIDRIVE® MDX60B/61B

Wiring diagram for basic unit

Brake rectifier in the control cabinet

Install the connection cables between the brake rectifier and the brake separately from other power cables when installing the brake rectifier in the control cabinet. Joint installation is only permitted with shielded power cables.

1.2.2 Power section and DC power supply unit (size7)

For connecting the brake, refer to the wiring diagram of size 1-6.

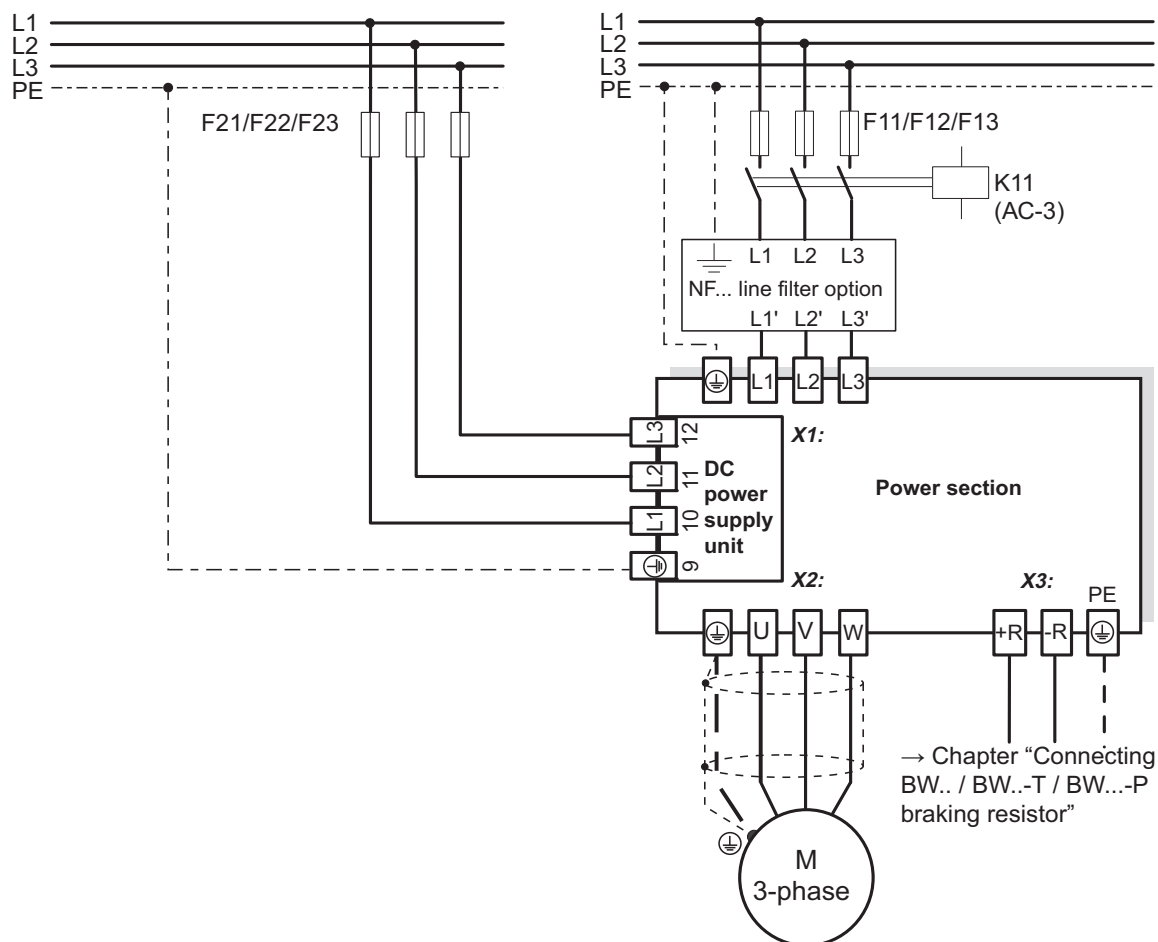

2079053451

Technical data of DC power supply unit:

- Rated current: AC 2.4 A
- Inrush current AC 30 A / AC 380 - 500 V



INFORMATION

Note that the connection of external +24 V power supply units to the X10:9 control terminal is not permitted in backup mode via power supply unit. Incorrect connection prompts an error message.



1.2.3 Braking resistor BW... / BW...-T / BW...-P

Power section

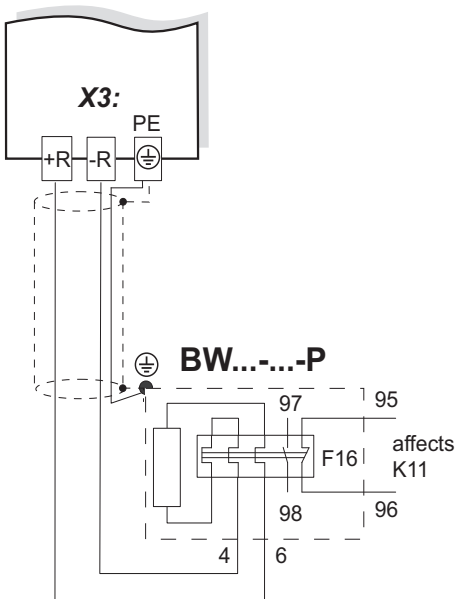

When the signal contact F16 trips, K11 must be opened and DIØØ"/Controller inhibit" must receive a "0" signal. The resistor circuit must not be interrupted!

Power section

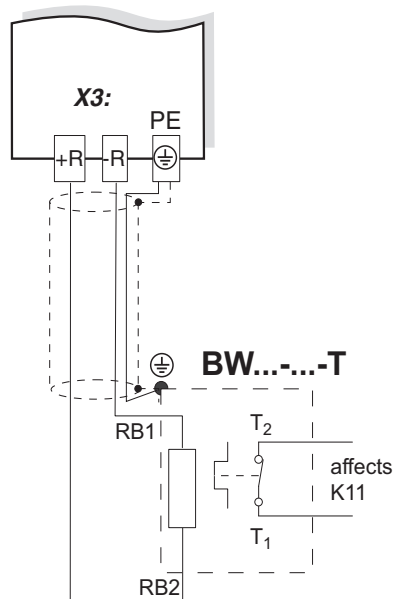

When the internal temperature switch trips, K11 must be opened and DIØØ"/Controller inhibit" must receive a "0" signal. The resistor circuit must not be interrupted!

Power section

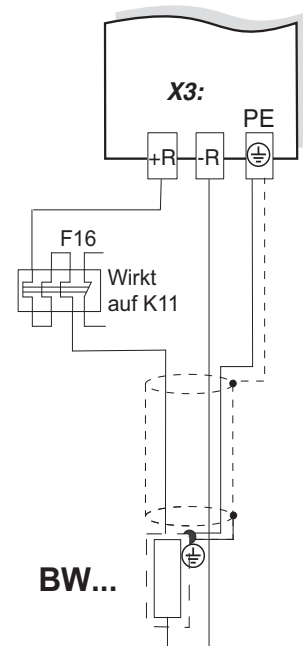

When the external bimetal relay (F16) trips, K11 must be opened and DIØØ"/Controller inhibit" must receive a "0" signal. The resistor circuit must not be interrupted!

1805563147

Braking resistor type	Design specified	Overload protection	
		Internal temperature switch (...T)	External bimetallic relay (F16)
BW...	-	-	Required
BW...-T	-	One of the two options (internal temperature switch/external bimetallic relay) is required.	
BW...-003 / BW...-005	Adequate	-	Permitted
BW090-P52B	Adequate	-	-



2 MOVIDRIVE® MDR60A/61B and MDX62B

2.1 Information regarding UL

2.1.1 Field wiring power terminals

- MOVIDRIVE® MDR60A0150 – 0750 and MOVIDRIVE® MDR61B1600 – 2500: Use 60/75 °C copper wire only.
MOVIDRIVE® MDX62B1600 – 2500: Use 75 °C copper wire only.
- Tighten terminals to in-lbs (Nm) as follows:

Series	Size	in-lbs	Nm
MOVIDRIVE® MDR60A/61B MDX62B	2	16	1.8
	3	31	3.5
	4	120	14
	7	620	70

2.1.2 Short circuit current rating

- MOVIDRIVE® MDR60A0150 – 0750 and MOVIDRIVE® MDR61B1600 – 2500:
When these regenerative power supply units are installed with the appropriate MOVIDRIVE® inverter, the system can be marked with the short circuit rating of the inverter.
Suitable for use on a circuit capable of delivering not more than
 - 200,000 rms symmetrical amperes when protected by fuses and circuit breakers as described in the tables below.
 - 65,000 rms symmetrical amperes when protected by ABB and Rockwell Type E Combination Motor controllers as described in the tables below.
 - Max. voltage is limited to 500 V.
- MOVIDRIVE® MDX62B1600 – 2500:
Suitable for use on a circuit capable of delivering not more than
 - 200,000 rms symmetrical amperes when protected by fuses and circuit breakers as described in the tables below.
 - 65,000 rms symmetrical amperes when protected by ABB and Rockwell Type E Combination Motor controllers as described in the tables below.
 - Max. voltage is limited to 500 V.



2.1.3 Branch circuit protection

Integral solid state short circuit protection does not provide branch circuit protection. Branch circuit protection must be provided in accordance with the National Electrical Code and any additional local codes.

MOVIDRIVE® MDR60A/61B

Model	SCCR: 200 kA/ 500 V when protected by: Non Semiconductor Fuses (currents are maximum values)	SCCR: 200 kA/ 500 V when protected by: Inverse-Time Circuit Breaker	SCCR: 65 kA/ 480 V when protected by: Type E Combination Motor Controller	SCCR: 65 kA/ 460 V when protected by:
MDR60A0150	50 A / 600 V	-	ABB, Model MS450-50E Rated 480V, 40 HP	Rockwell Automation Model 140M-F8E-C45, Rated 460V, 40 HP
MDR60A0370	100 A / 600 V	-	ABB, Model MS495-75E Rated 480V, 60 HP	-
MDR60A0750	175 A / 600 V	175 A max / 500 V Min	-	-
MDR61B1600	400 A / 600 V	600 A max / 500 V Min	-	-
MDR61B2500	600 A / 600 V	600 A max / 500 V Min	-	-

MOVIDRIVE® MDX62B

Three Phase 380 V – 500 V Voltage Range				
Model	SCCR: 200 kA/ 500 V when protected by: Non Semiconductor Fuses (currents are maximum values)	SCCR: 200 kA/ 500 V when protected by Inverse-Time Circuit Breaker	SCCR: 65 kA/ 480 V when protected by: Type E Combination Motor Controller	SCCR: 65 kA/ 460 V when protected by:
MOVIDRIVE MODEL, 1600 (Size 7)	400 A / 600 V	600 A max / 500 V Min	-	-
MOVIDRIVE MODEL, 2000 (Size 7)	500 A / 600 V	600 A max / 500 V Min	-	-
MOVIDRIVE MODEL, 2500 (Size 7)	600 A / 600 V	600 A max / 500 V Min	-	-



2.1.4 Motor overload protection

MOVIDRIVE® MDX62B1600 – 2500: The units are provided with load and speed-sensitive overload protection and thermal memory retention upon shutdown or power loss.

The trip current is adjusted to 150 % of the rated motor current.

2.1.5 Ambient temperature

The units are suitable for an ambient temperature of 40 °C, max. 60 °C with derated output current.

MOVIDRIVE® MDR60A0150 – 0750: To determine the output current rating at higher than 40 °C, the output current should be derated 3.0 % per °C between 40 °C and 60 °C.

MOVIDRIVE® MDR61B1600 – 2500 and MOVIDRIVE® MDX62B1600 – 2500: To determine output current rating at higher than 40 °C, the output current should be derated 2.5% per °C between 40 °C and 50 °C, and 3% per °C between 50 °C and 60 °C.



INFORMATION

- Use only tested units with a **limited output voltage** ($U_{\max} = \text{DC } 30 \text{ V}$) and **limited output current** ($I_{\max} = 8 \text{ A}$) as an **external DC 24 V voltage source**.
- **UL certification does not apply to operation in voltage supply systems with a non-grounded star point (IT systems).**



2.2.2 DC link connection with MDR60A0150 regenerative power supply unit as brake module

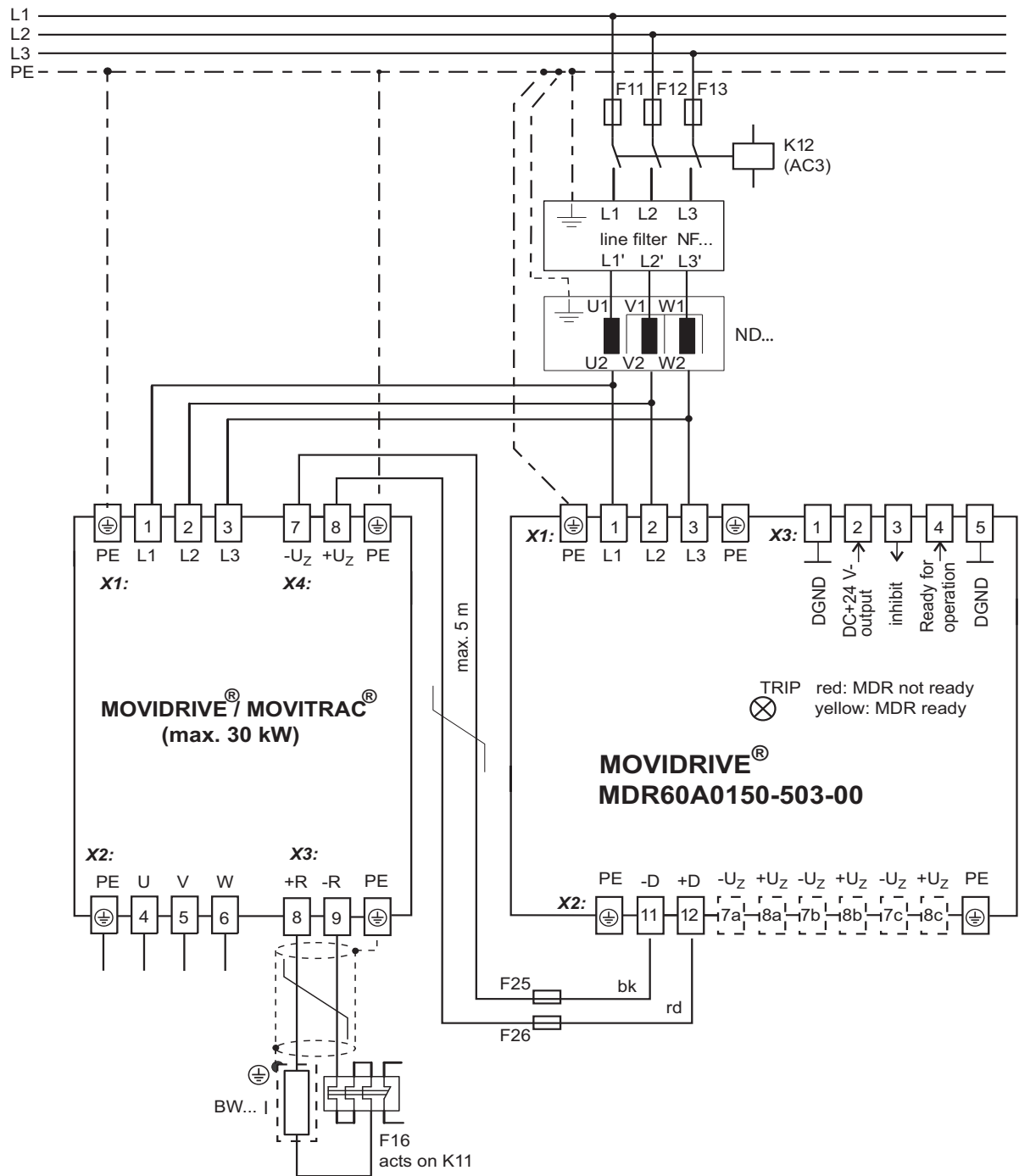

3627533963



2.2.3 DC link connection with MDR61B1600/2500 regenerative power supply unit

In conjunction with MOVIDRIVE® MDX61B/62B1600 – 2500 (size 7)

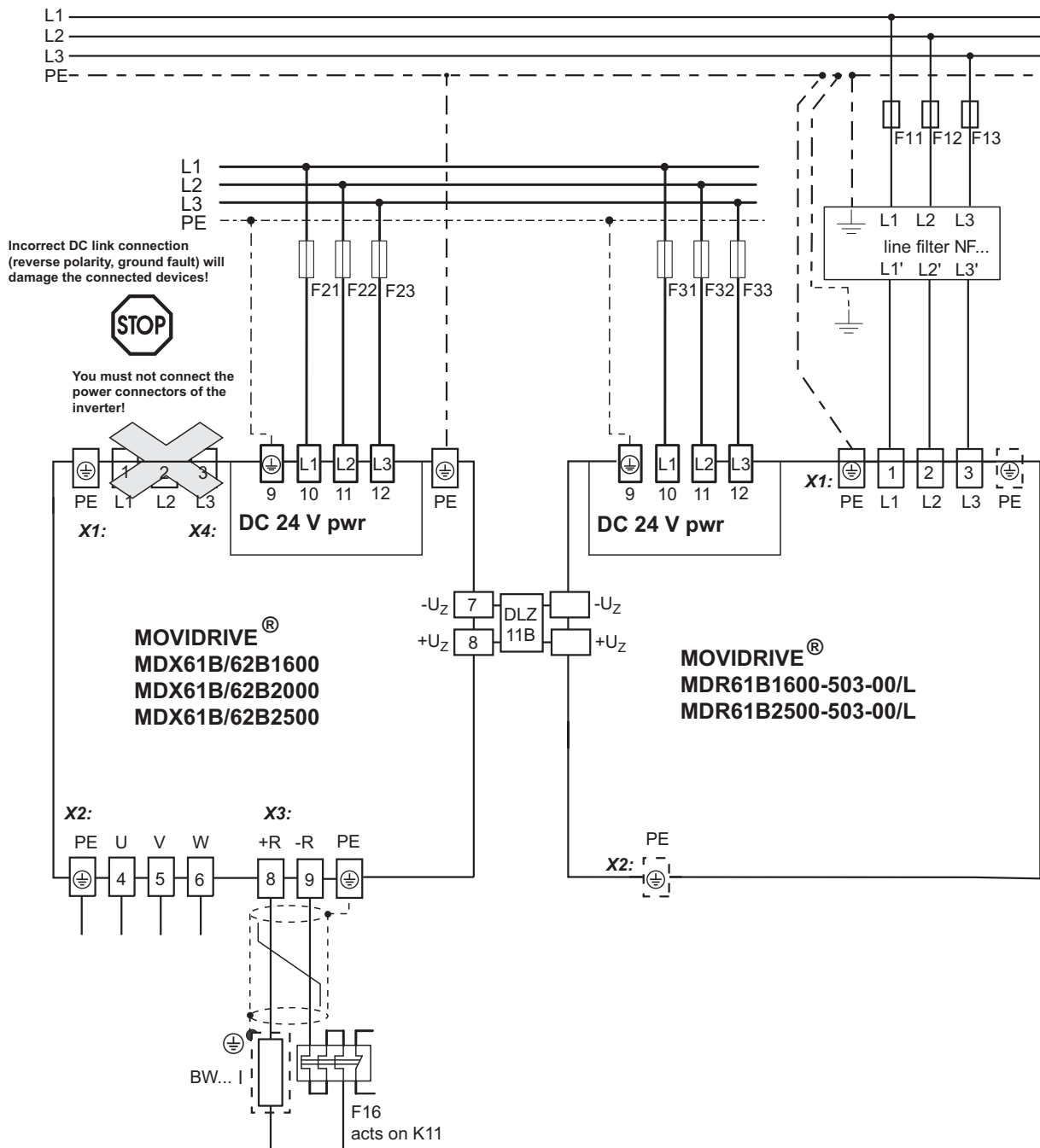

3347843723



3 MOVIDRIVE® compact

3.1 Information Regarding UL

3.1.1 Field wiring power terminals

- Use 60/75 °C copper wire only – Models with suffix 0015 to 0300.
Use 75 °C copper wire only – Models with suffix 0370 to 0750.
- Tighten terminals to in-lbs (Nm) as follows:

Series	Frame Size	in-lbs	Nm
MOVIDRIVE® compact	1	5	0.6
	2	13	1.5
	3	31	3.5
	4, 5	120	14

3.1.2 Short circuit current rating

- Suitable for use on a circuit capable of delivering not more than 200,000 rms symmetrical amperes when protected by fuses as described in the tables below.
 - MOVIDRIVE® compact models with suffix 0015 to 0750 (400 V units only).
Max. voltage is limited to 500 V.
 - MOVIDRIVE® compact models with suffix 0015 to 0300 (230 V units only).
Max. voltage is limited to 240 V.



3.1.3 Branch circuit protection

Integral solid state short circuit protection does not provide branch circuit protection. Branch circuit protection must be provided in accordance with the National Electrical Code and any additional local codes.

For maximum fuse rating see tables below.

400/500 V units

MOVIDRIVE® compact MC_4_A...5_3	Max. supply short circuit current	Max. supply voltage	Max. fuse rating Non Semiconductor Fuses
0015/0022/0030/0040	AC 200000 A	AC 500 V	AC 35 A / 600 V
0055/0075/0110	AC 200000 A	AC 500 V	AC 110 A / 600 V
0150/0220	AC 200000 A	AC 500 V	AC 175 A / 600 V
0300	AC 200000 A	AC 500 V	AC 225 A / 600 V
0370/0450	AC 200000 A	AC 500 V	AC 350 A / 600 V
0550/0750	AC 200000 A	AC 500 V	AC 500 A / 600 V

230 V units

MOVIDRIVE® compact MC_4_A...2_3	Max. supply short circuit current	Max. supply voltage	Max. fuse rating Non Semiconductor Fuses
0015/0022/0037	AC 200000 A	AC 240 V	AC 30 A / 250 V
0055/0075	AC 200000 A	AC 240 V	AC 110 A / 250 V
0110	AC 200000 A	AC 240 V	AC 175 A / 250 V
0150	AC 200000 A	AC 240 V	AC 225 A / 250 V
0220/0300	AC 200000 A	AC 240 V	AC 350 A / 250 V

3.1.4 Motor overload protection

Motor over temperature sensing is required.

3.1.5 Ambient temperature

The units are suitable for an ambient temperature of 40 °C, max. 60 °C with derated output current.

To determine output current rating at higher than 40 °C, the output current should be derated 2.5 % per °C between 40 °C and 50 °C, and 3 % per °C between 50 °C and 60 °C.

	NOTES
	<ul style="list-style-type: none"> • An external DC 24 V voltage supply has to be limited to a max. voltage $U_{max} = DC 30 V$ and max. current $I_{max} = 8 A$. • UL certification does not apply to operation in voltage supply systems with a non-grounded star point (IT systems).



3.2 Wiring diagram for basic unit

3.2.1 Wiring the power section and brake

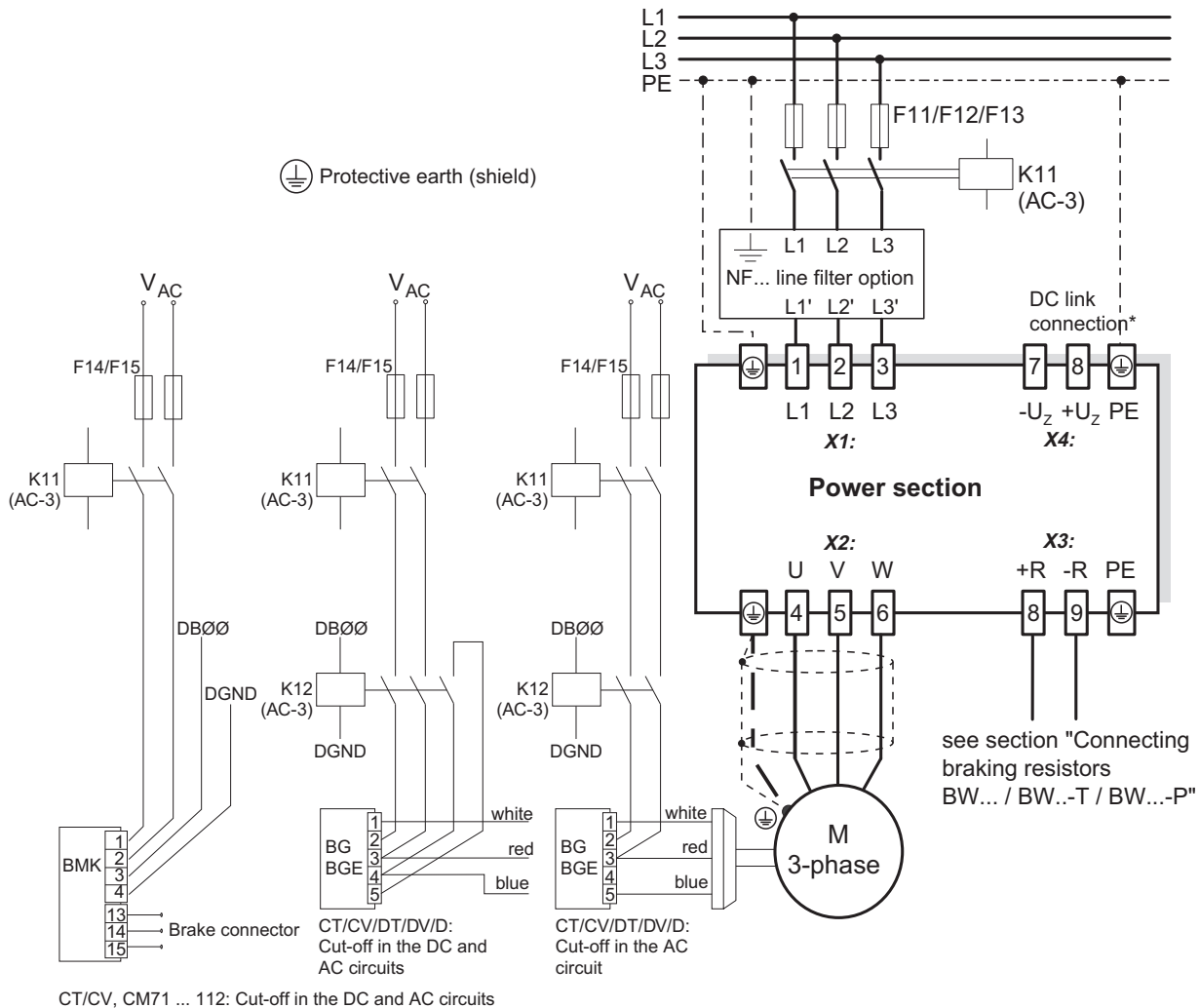

55310CEN

Figure 1: Wiring diagram, power section and brake

* With sizes 1 and 2, there is no PE connection next to the supply system connection terminals and motor connection terminals (X1, X2). In this case, use the PE terminal next to the DC link connection (X4).

Important: Read the operating instructions for the motors when connecting the brake.



STOP!

If the brake rectifier is connected via the supply system lead, the braking function is restricted.

- Connect the brake rectifier using a separate supply system lead.
- **Supply via the motor voltage is not permitted!**

Always switch off the brake on the DC and AC sides with:

- All hoist applications
- Drives that require a rapid brake response time
- CFC and SERVO operating modes



Brake rectifier in control cabinet

Install the connection cables between the brake rectifier and the brake separately from other power cables when installing the brake rectifier in the control cabinet. Joint installation is only permitted with shielded power cables.

3.2.2 Connecting BW... / BW...-T / BW...-P braking resistors

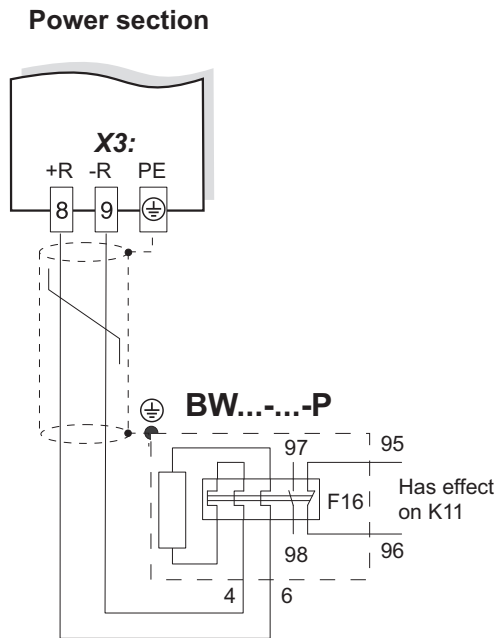

When the auxiliary contact trips, K11 must be opened and DIØØ"/Controller inhibit" assigned a "0" signal. Do not interrupt the resistor circuit!

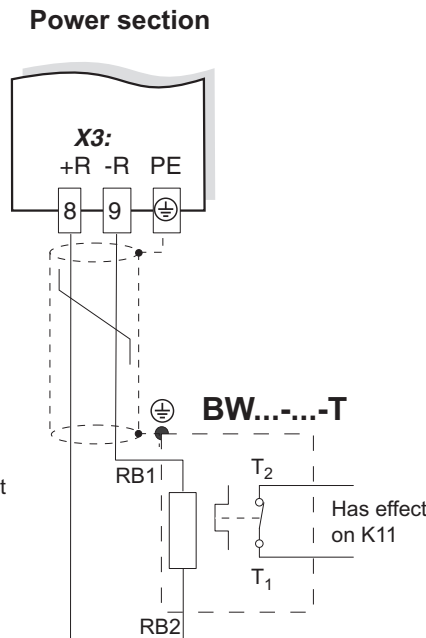

When the internal temperature switch triggers, K11 must be opened and DIØØ"/Controller inhibit assigned a "0" signal. Do not interrupt the resistor circuit!

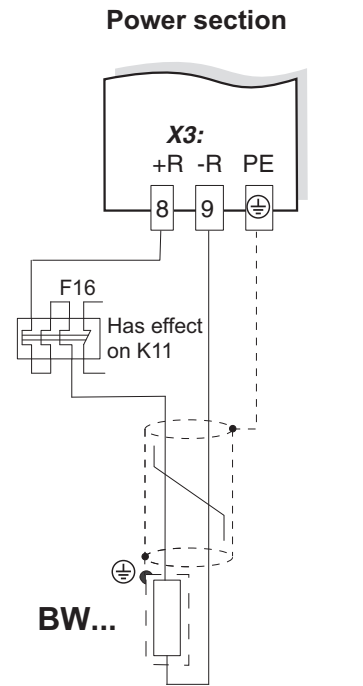

When the external bimetallic relay (F16) triggers, K11 must be opened and DIØØ"/Controller inhibit" assigned a "0" signal. Do not interrupt the resistor circuit!

59500AEN

Braking resistor type	Design specified	Overload protection	
		Internal temperature switch (..T)	External bimetallic relay (F16)
BW...	-	-	Required
BW...-T	-	One of the two options (internal temperature switch / external bimetallic relay) is required.	
BW...-003 / BW...-005	Adequate	-	Permitted



4 MOVIDRIVE® A

4.1 Information Regarding UL

4.1.1 Field wiring power terminals

- Use 60/75 °C copper wire only – Models with suffix 0015 to 0300.
Use 75 °C copper wire only – Models with suffix 0370 to 0750.
- Tighten terminals to in-lbs (Nm) as follows:

Series	Frame Size	in-lbs	Nm
MOVIDRIVE® A	1	5	0.6
	2	13	1.5
	3	31	3.5
	4, 5	120	14

4.1.2 Short circuit current rating

- Suitable for use on a circuit capable of delivering not more than 200,000 rms symmetrical amperes when protected by fuses as described in the tables below.
 - MOVIDRIVE® A models with suffix 0015 to 0750 (400 V units only).
Max. voltage is limited to 500 V.
 - MOVIDRIVE® A models with suffix 0015 to 0300 (230 V units only).
Max. voltage is limited to 240 V.



4.1.3 Branch circuit protection

Integral solid state short circuit protection does not provide branch circuit protection. Branch circuit protection must be provided in accordance with the National Electrical Code and any additional local codes.

For maximum fuse rating see tables below.

400/500 V units

MOVIDRIVE® MD_60A...5_3	Max. supply short circuit current	Max. supply voltage	Max. fuse rating Non Semiconductor Fuses
0015/0022/0030/0040	AC 200000 A	500 VAC	35 A / 600 V
0055/0075/0110	AC 200000 A	500 VAC	110 A / 600 V
0150/0220	AC 200000 A	500 VAC	175 A / 600 V
0300	AC 200000 A	500 VAC	225 A / 600 V
0370/0450	AC 200000 A	500 VAC	350 A / 600 V
0550/0750	AC 200000 A	500 VAC	500 A / 600 V

230 V units

MOVIDRIVE® MD_60A...2_3	Max. supply short circuit current	Max. supply voltage	Max. fuse rating Non Semiconductor Fuses
0015/0022/0037	AC 200000 A	240 VAC	30 A / 250 V
0055/0075	AC 200000 A	240 VAC	110 A / 250 V
0110	AC 200000 A	240 VAC	175 A / 250 V
0150	AC 200000 A	240 VAC	225 A / 250 V
0220/0300	AC 200000 A	240 VAC	350 A / 250 V

4.1.4 Motor overload protection

Motor over temperature sensing is required.

4.1.5 Ambient temperature

The units are suitable for an ambient temperature of 40 °C, max. 60 °C with derated output current.

To determine output current rating at higher than 40 °C, the output current should be derated 2.5 % per °C between 40 °C and 50 °C, and 3 % per °C between 50 °C and 60 °C.

	NOTES
	<ul style="list-style-type: none"> • An external DC 24 V voltage supply has to be limited to a max. voltage $U_{max} = DC 30 V$ and max. current $I_{max} = 8 A$. • UL certification does not apply to operation in voltage supply systems with a non-grounded star point (IT systems).



4.2 Wiring diagram for basic unit

4.2.1 Connection of the power section and brake

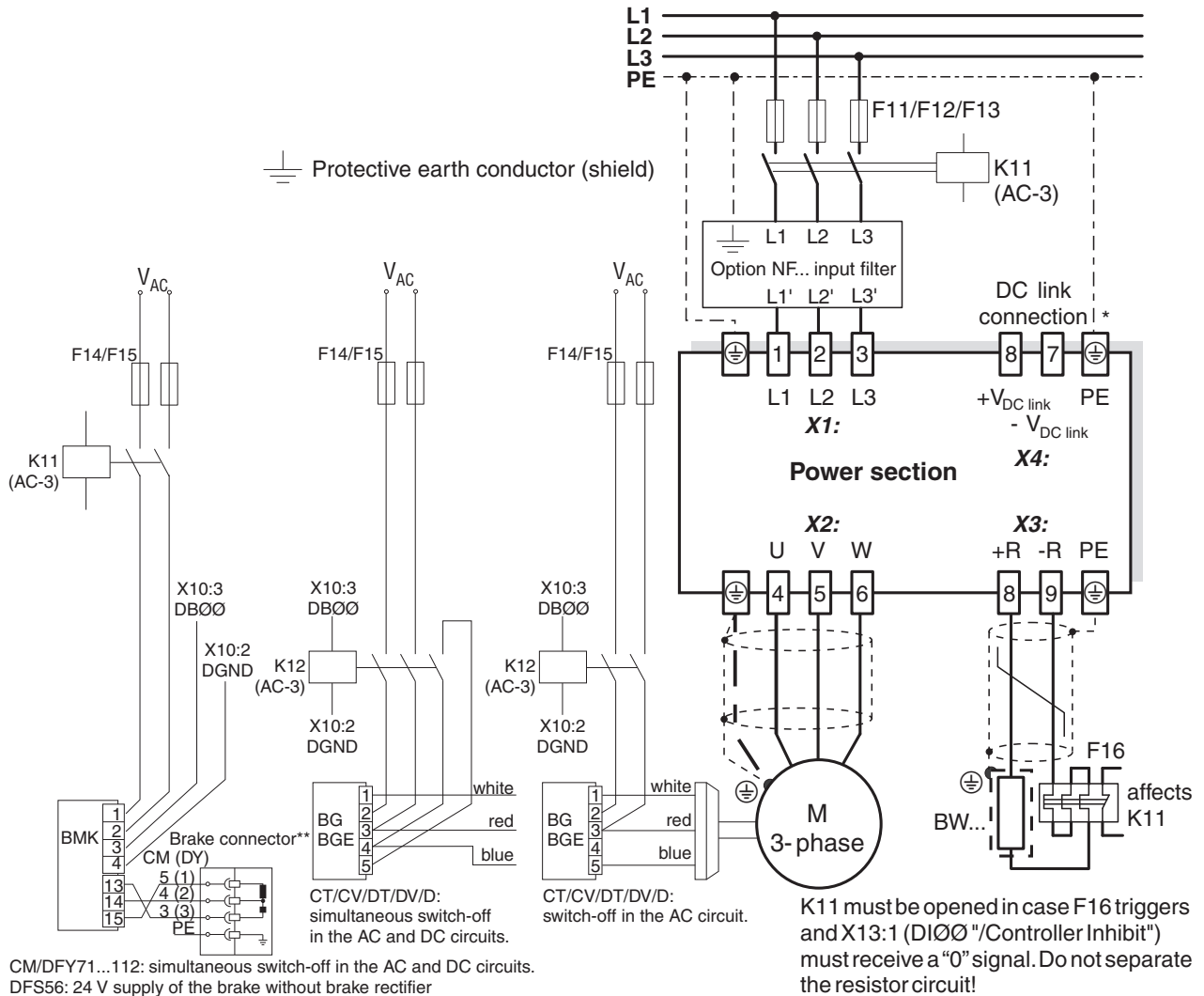

05229AEN

Figure 2: Wiring diagram, power section and brake

* With sizes 1 and 2, there is no PE connection next to the mains connection terminals. In this case, use the PE terminal next to the DC link connection.

Important: It is essential to adhere to the sequence of connections. Incorrect connection will lead to irreparable damage to the brake.

	<p>STOP!</p> <p>A separate supply system lead is required for connecting the brake rectifier. Powering it from the motor voltage is not permitted!</p>
--	--

Always switch off the brake on the DC and AC sides under the following conditions:

- all hoist applications,
- drives which require a rapid brake reaction time and
- in CFC and SERVO operating modes.



*Brake rectifier in
switch cabinet*

Route the connection cables between the brake rectifier and the brake separately from other power cables when installing the brake rectifier in the switch cabinet. Joint routing is only permitted if the power cables are shielded.

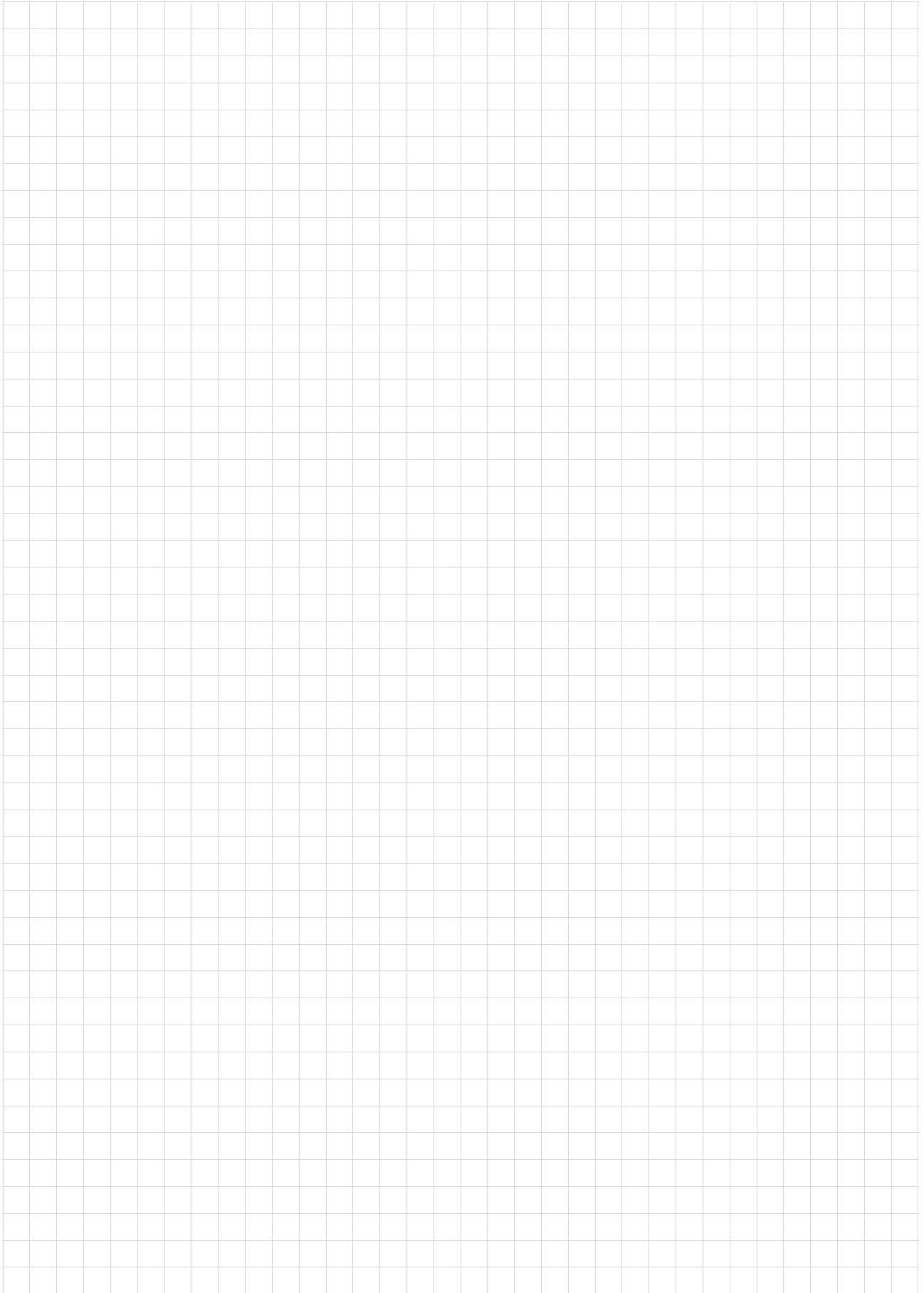

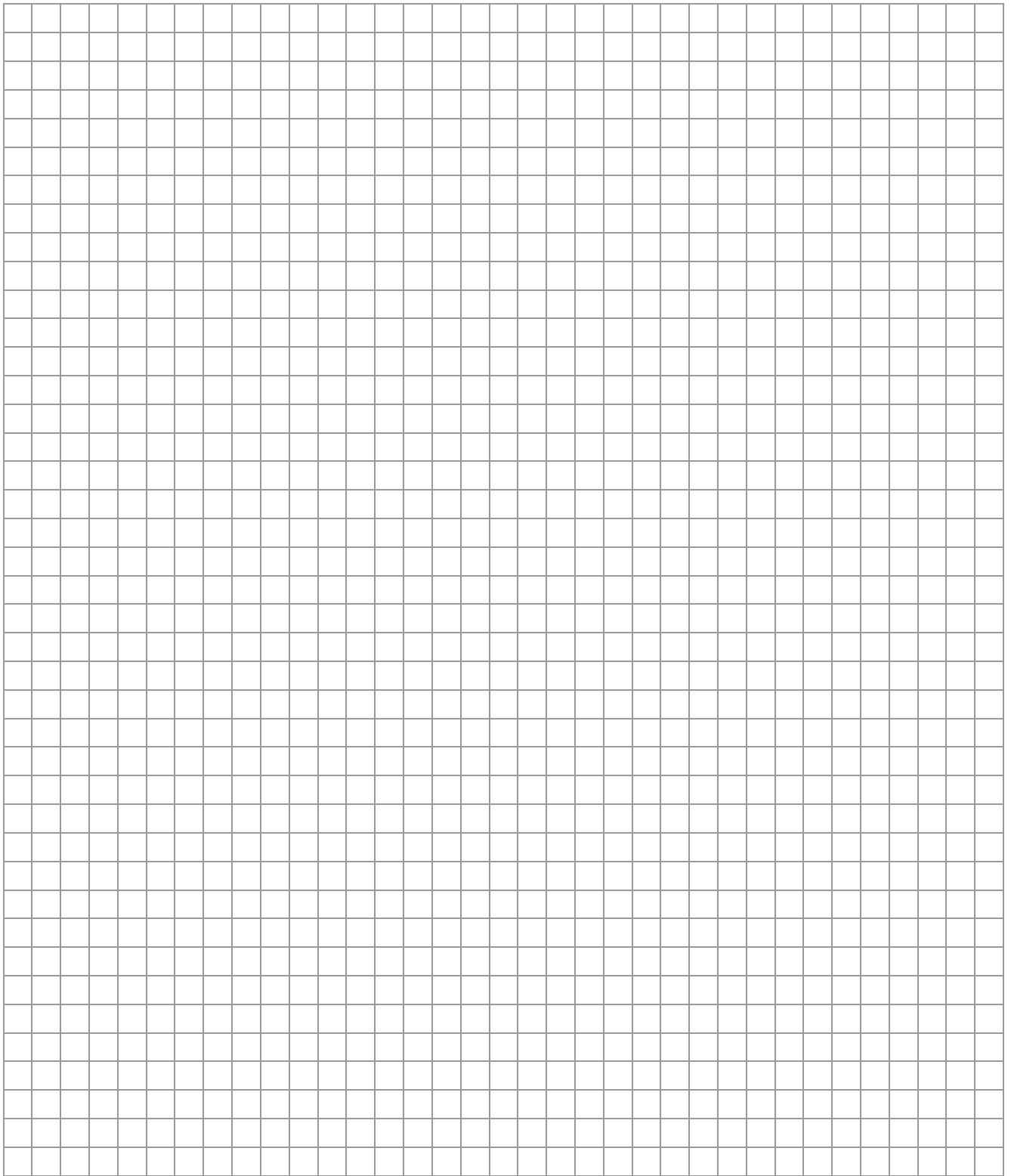



SEW-EURODRIVE
Driving the world

SEW
EURODRIVE

SEW-EURODRIVE GmbH & Co KG
P.O. Box 3023
D-76642 Bruchsal/Germany
Phone +49 7251 75-0
Fax +49 7251 75-1970
sew@sew-eurodrive.com

→ www.sew-eurodrive.com