

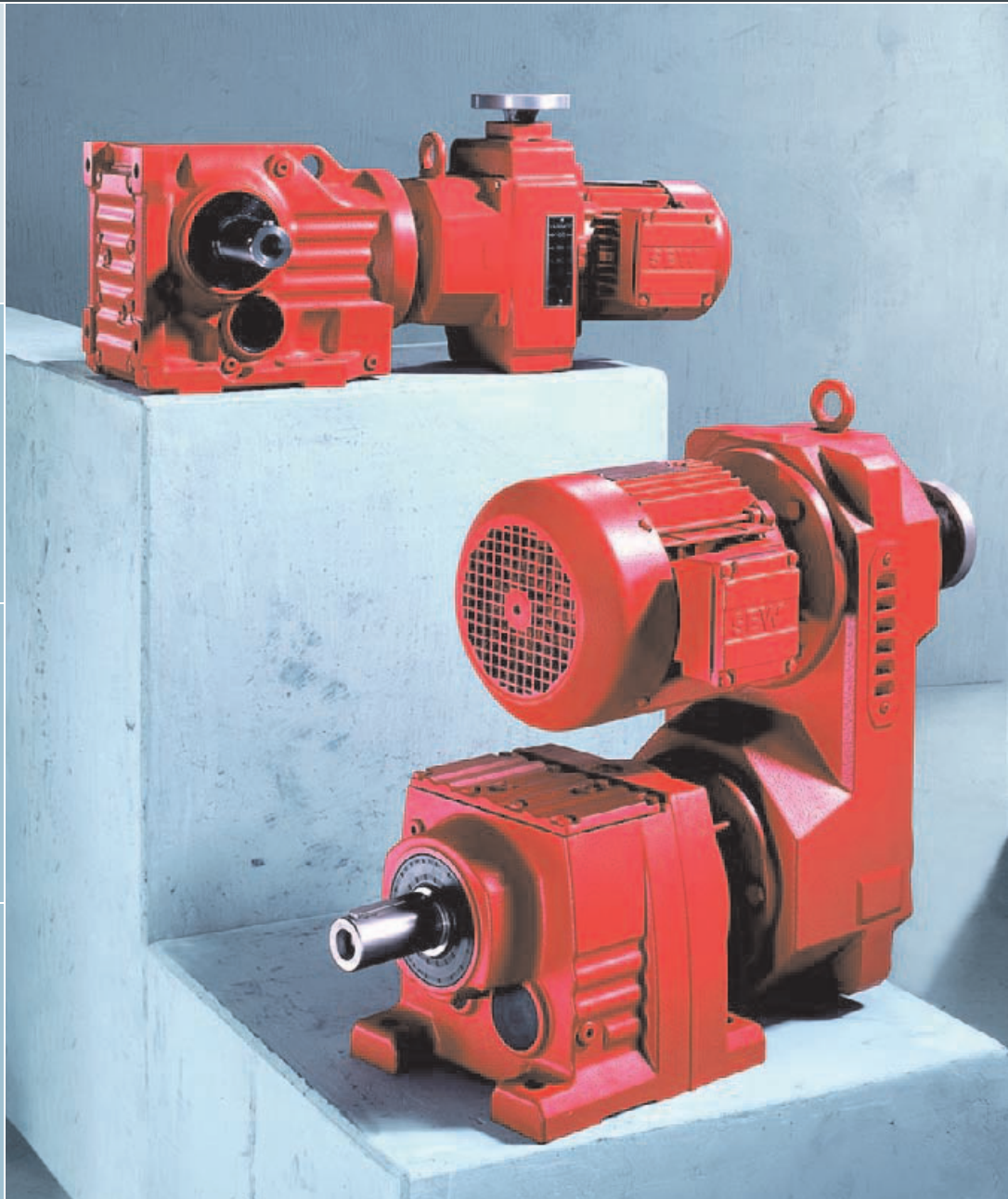

**SEW**  
EURODRIVE

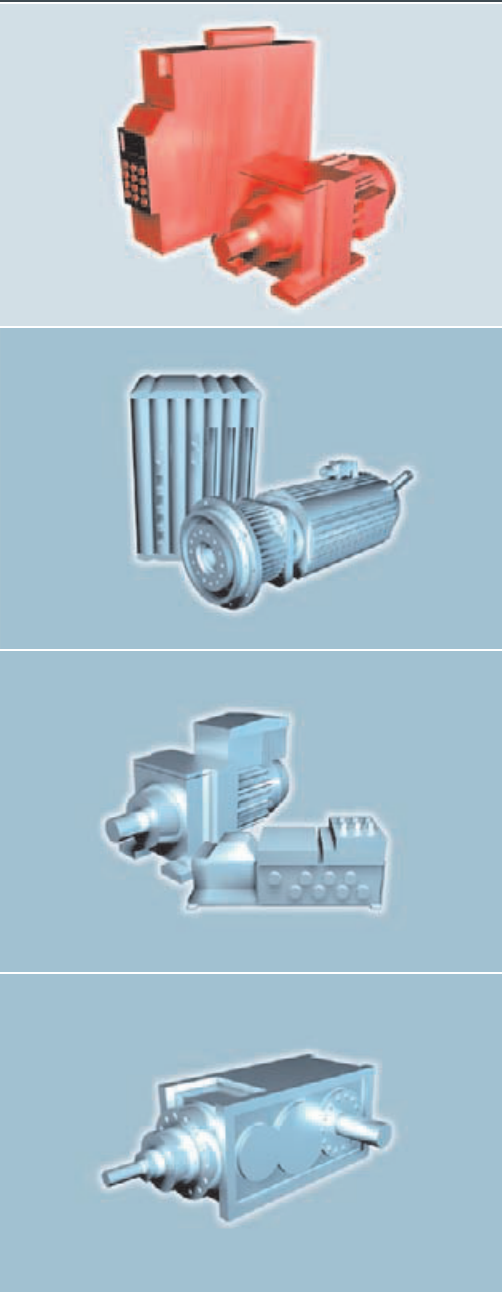

## Variable Speed Gearmotors

A3.D03







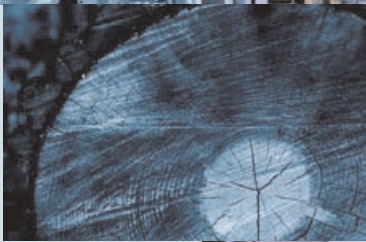
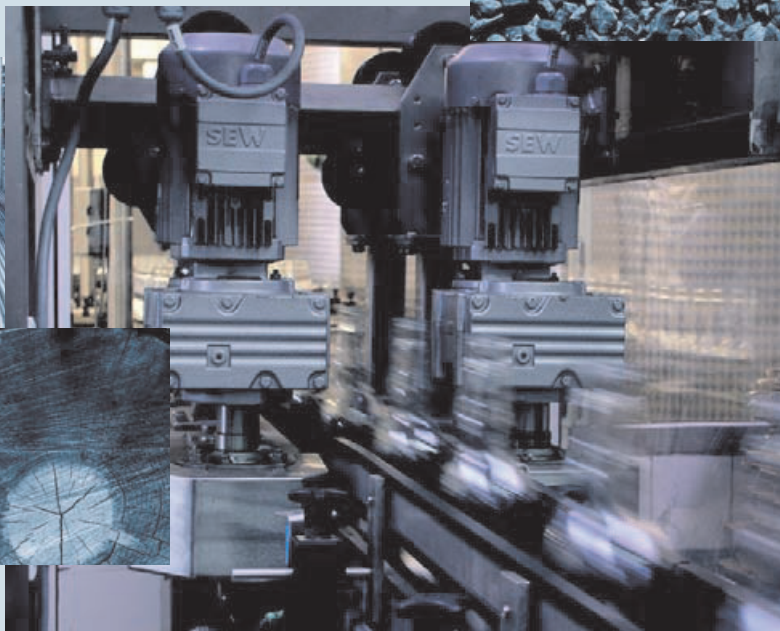
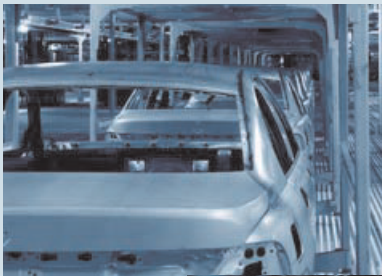
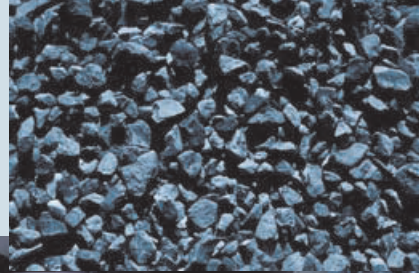











Edition 08/2004

11230126 / EN

# Catalog





	<b>1</b>	<b>The SEW-EURODRIVE Group of Companies .....</b>	<b>7</b>	<b>1</b>
	<b>2</b>	<b>Product Description and Overview of Types.....</b>	<b>9</b>	<b>2</b>
	<b>3</b>	<b>Explosion Protection to ATEX .....</b>	<b>34</b>	<b>3</b>
	<b>4</b>	<b>Project Planning for Variable Speed Drives .....</b>	<b>43</b>	<b>4</b>
	<b>5</b>	<b>Mounting Positions.....</b>	<b>92</b>	<b>5</b>
	<b>6</b>	<b>Design and Operating Notes.....</b>	<b>126</b>	<b>6</b>
	<b>7</b>	<b>Important Information, Tables and Dimension Sheets.....</b>	<b>149</b>	<b>7</b>
	<b>8</b>	<b>VARIBLOC® Foot-Mounted VU/VZ and Flange-Mounted VUF/VZF.....</b>	<b>155</b>	<b>8</b>
	<b>9</b>	<b>VARIBLOC® with Helical Gear Unit R.....</b>	<b>167</b>	<b>9</b>
	<b>10</b>	<b>VARIBLOC® with Parallel Shaft Helical Gear Unit F .....</b>	<b>249</b>	<b>10</b>
	<b>11</b>	<b>VARIBLOC® with Helical-Bevel Gear Unit K.....</b>	<b>295</b>	<b>11</b>
	<b>12</b>	<b>VARIBLOC® with Helical-Worm Gear Unit S.....</b>	<b>349</b>	<b>12</b>
	<b>13</b>	<b>VARIMOT® Foot-Mounted and Flange-Mounted Version D/DF.....</b>	<b>381</b>	<b>13</b>
	<b>14</b>	<b>VARIMOT® with Helical Gear Unit R.....</b>	<b>389</b>	<b>14</b>
	<b>15</b>	<b>VARIMOT® with Parallel Shaft Helical Gear Unit F.....</b>	<b>439</b>	<b>15</b>
	<b>16</b>	<b>VARIMOT® with Helical-Bevel Gear Unit K .....</b>	<b>471</b>	<b>16</b>
	<b>17</b>	<b>VARIMOT® with Helical-Worm Gear Unit S.....</b>	<b>517</b>	<b>17</b>
	<b>18</b>	<b>AC Motors .....</b>	<b>547</b>	<b>18</b>
	<b>19</b>	<b>Abbreviation Key and Index.....</b>	<b>574</b>	<b>19</b>



<b>1</b>	<b>The SEW-EURODRIVE Group of Companies .....</b>	<b>7</b>
<b>2</b>	<b>Product Description and Overview of Types.....</b>	<b>9</b>
2.1	VARIBLOC® variable speed gearmotor .....	10
2.2	VARIMOT® variable speed gearmotor.....	11
2.3	General information .....	12
2.4	Variable speed gearmotor versions .....	13
2.5	Unit designations for variable speed gear units and options .....	15
2.6	Gear unit designations .....	16
2.7	Unit designations for AC motors and options.....	17
2.8	Sample unit designation of a variable speed gearmotor.....	18
2.9	Versions .....	20
<b>3</b>	<b>Explosion protection to ATEX .....</b>	<b>34</b>
3.1	Drive engineering to EU Directive 94/9/EC (ATEX 100a) .....	34
3.2	Regulations .....	36
3.3	Categories and protection types .....	39
3.4	Requirements for operating variable speed gear units in potentially explosive atmospheres .....	41
3.5	VARIBLOC® in explosion-proof design.....	41
3.6	VARIMOT® in explosion-proof design .....	42
3.7	Drive selection for explosion protected designs.....	42
<b>4</b>	<b>Project Planning for Variable Speed Drives .....</b>	<b>43</b>
4.1	Additional documentation.....	43
4.2	Drive selection data for standard variable speed gearmotors.....	44
4.3	Drive selection data for explosion-proof standard variable speed gearmotors .....	45
4.4	Project planning process for standard variable speed gearmotors.....	46
4.5	Project planning notes for standard variable speed gearmotors.....	47
4.6	Efficiency of SEW gear units.....	47
4.7	Permitted overhung loads of reduction gear units .....	52
4.8	RM gear units.....	65
4.9	Standard variable speed gearmotor selection .....	68
4.10	Service factors .....	69
4.11	Protection and monitoring of standard variable speed gearmotors .....	72
4.12	VARIBLOC® options .....	74
4.13	VARIMOT® options.....	85
<b>5</b>	<b>Mounting Positions.....</b>	<b>92</b>
5.1	General information on mounting positions .....	92
5.2	Important order information.....	93
5.3	Overview of standard VARIBLOC® and gear unit combinations .....	96
5.4	Key to mounting position sheets .....	106
5.5	VARIMOT® D.. variable speed gear units.....	107
5.6	VARIMOT® DF... variable speed gear units .....	108
5.7	Variable speed gearmotors with helical gear unit .....	109
5.8	Variable speed gearmotors with parallel shaft helical gear unit.....	114
5.9	Variable speed gearmotors with helical-bevel gear unit .....	117
5.10	Variable speed gearmotors with helical-worm gear unit .....	120



<b>6</b>	<b>Design and Operating Notes.....</b>	<b>126</b>	
6.1	Lubricants .....	126	<b>1</b>
6.2	Lubricant table for standard variable speed gearmotors.....	127	<b>2</b>
6.3	Lubricant table for explosion-proof variable speed gearmotors .....	128	<b>3</b>
6.4	Lubricant fill quantities for variable speed gearmotors.....	129	<b>4</b>
6.5	Installation/removal of gear units with hollow shafts and keys.....	133	<b>5</b>
6.6	Gear units with hollow shaft .....	136	<b>6</b>
6.7	TorqLOC® mounting system for units with hollow shaft.....	137	<b>7</b>
6.8	Option, offset hollow shaft with shrink disc .....	139	<b>8</b>
6.9	Flange contours of the RF.. and R..F gear units.....	146	<b>9</b>
6.10	Fastening of gear units .....	147	<b>10</b>
6.11	Torque arms.....	147	<b>11</b>
6.12	Fixed covers.....	148	<b>12</b>
<b>7</b>	<b>Important Information, Tables and Dimension Sheets .....</b>	<b>149</b>	<b>13</b>
7.1	Structure of the selection tables.....	149	<b>14</b>
7.2	Dimension sheet information .....	151	<b>15</b>
<b>8</b>	<b>VARIBLOC® foot-mounted VU/VZ and flange-mounted VUF/VZF.. .....</b>	<b>155</b>	<b>16</b>
8.1	VARIBLOC® in foot-mounted version .....	155	<b>17</b>
8.2	Selection tables for VARIBLOC® foot-mounted and flange-mounted ..	156	<b>18</b>
8.3	Selection tables for VARIBLOC® foot-mounted and flange-mounted, non-ventilated .....	159	<b>19</b>
8.4	Dimension sheets for VARIBLOC® foot-mounted and flange-mounted	160	
<b>9</b>	<b>VARIBLOC® with helical gear unit R.. .....</b>	<b>167</b>	
9.1	VARIBLOC® with helical gear unit.....	167	
9.2	Selection tables for VARIBLOC® with helical gear unit .....	168	
9.3	Dimension sheets for VARIBLOC® with helical gear unit .....	212	
<b>10</b>	<b>VARIBLOC® with parallel shaft helical gear unit F.. .....</b>	<b>249</b>	
10.1	VARIBLOC® with parallel shaft helical gear unit.....	249	
10.2	Selection tables for VARIBLOC® with parallel shaft helical gear unit ..	251	
10.3	Dimension sheets for VARIBLOC® with parallel shaft helical gear unit	274	
10.4	Dimension sheets for VARIBLOC® with parallel shaft helical gear unit and torque arm F../G.....	294	
<b>11</b>	<b>VARIBLOC® with helical-bevel gear unit K.....</b>	<b>295</b>	
11.1	VARIBLOC® with helical-bevel gear unit.....	295	
11.2	Selection tables for VARIBLOC® with helical-bevel gear unit.....	297	
11.3	Dimension sheets for VARIBLOC® with helical-bevel gear unit.....	318	
11.4	Dimension sheets for VARIBLOC® with helical-bevel gear unit and torque arm KA../T.....	348	
<b>12</b>	<b>VARIBLOC® with helical-worm gear unit S.....</b>	<b>349</b>	
12.1	VARIBLOC® with helical-worm gear unit.....	349	
12.2	Selection tables for VARIBLOC® with helical-worm gear unit.....	351	
12.3	Dimension sheets for VARIBLOC® with helical-worm gear unit .....	366	
12.4	Dimension sheets for VARIBLOC® with helical-worm gear unit and torque arm S../T.....	380	
<b>13</b>	<b>VARIMOT® foot-mounted and flange-mounted D/DF.....</b>	<b>381</b>	
13.1	VARIMOT® in foot-mounted and flange-mounted version.....	381	
13.2	Selection tables for VARIMOT® foot-mounted and flange-mounted....	382	
13.3	Dimension sheets for VARIMOT® foot-mounted and flange-mounted.	384	



<b>14</b>	<b>VARIMOT<sup>®</sup> with helical gear unit R..</b>	<b>389</b>
14.1	VARIMOT <sup>®</sup> with helical gear unit..	389
14.2	Selection tables for VARIMOT <sup>®</sup> with helical gear unit .....	390
14.3	Dimension sheets for VARIMOT <sup>®</sup> with helical gear unit .....	409
<b>15</b>	<b>VARIMOT<sup>®</sup> with parallel shaft helical gear unit F.....</b>	<b>439</b>
15.1	VARIMOT <sup>®</sup> with parallel shaft helical gear unit. ....	439
15.2	Selection tables for VARIMOT <sup>®</sup> with parallel shaft helical gear unit ....	441
15.3	Dimension sheets for VARIBLOC <sup>®</sup> with parallel shaft helical gear unit.....	454
15.4	Dimension sheets for VARIBLOC <sup>®</sup> with parallel shaft helical gear unit and torque arm F../G.....	470
<b>16</b>	<b>VARIMOT<sup>®</sup> with helical-bevel gear unit K.....</b>	<b>471</b>
16.1	VARIMOT <sup>®</sup> with helical-bevel gear unit.. ....	471
16.2	Selection tables for VARIBLOC <sup>®</sup> with helical-bevel gear unit .....	473
16.3	Dimension sheets for VARIBLOC <sup>®</sup> with helical-bevel gear unit.....	492
16.4	Dimension sheets for VARIBLOC <sup>®</sup> with helical-bevel gear unit and torque arm KA../T.....	516
<b>17</b>	<b>VARIMOT<sup>®</sup> with helical-worm gear unit S.....</b>	<b>517</b>
17.1	VARIMOT <sup>®</sup> with helical-worm gear unit.. ....	517
17.2	Selection tables for VARIBLOC <sup>®</sup> with helical-worm gear unit .....	519
17.3	Dimension sheets for VARIBLOC <sup>®</sup> with helical-worm gear unit .....	531
17.4	Dimension sheets for VARIBLOC <sup>®</sup> with helical-worm gear unit and torque arm S../T.....	545
<b>18</b>	<b>AC motors.....</b>	<b>547</b>
18.1	Examples of different types.....	547
18.2	Technical data AC motors.....	548
18.3	Technical data on SEW brakes.....	558
18.4	Dimension sheets for AC motors .....	559
18.5	Additional lengths for brake motors .....	561
18.6	Technical data and dimensions of plug connectors .....	562
18.7	Protection canopy C.....	568
18.8	2nd shaft end .....	569
18.9	MOVI-SWITCH <sup>®</sup> .....	570
18.10	Dimensions of brake control systems .....	573
<b>19</b>	<b>Abbreviation Key and Index.....</b>	<b>574</b>
19.1	Abbreviation key .....	574
19.2	Index .....	575



## 1 The SEW-EURODRIVE Group of Companies

### **SEW- EURODRIVE Introduction**

SEW-EURODRIVE is a leading company in the global market for electrical drive engineering. Its global presence, extensive product range and broad spectrum of services make SEW-EURODRIVE the ideal partner for the machinery and plant construction industry when it comes to providing drive systems for demanding applications.

SEW-EURODRIVE possesses many years of experience in drive engineering which it puts to good use when developing, producing and selling all its drives with components drawn from mechanical and electrical engineering and electronics.

The company headquarters are in Bruchsal, Germany. Components for the SEW-EURODRIVE modular drive system are manufactured to the highest quality standards in production plants sited in Germany, France, Finland, the United States, Brazil and China. The individual drive systems are assembled with a consistently high quality standard and very short delivery times from stocked components in our assembly plants located in more than 30 industrialized countries all over the world. SEW-EURODRIVE sales, consulting, customer and spare parts services are available in more than 50 countries around the globe.

### **The product range**

- Gearmotors, gear units and motors
  - Helical gear units/gearmotors
  - Parallel shaft helical gear units/gearmotors
  - Helical-bevel gear units/gearmotors
  - Helical-worm gear units/gearmotors
  - Spiroplan® right-angle gearmotors
  - Planetary gearmotors
  - Industrial gear units
  - Low backlash gear units/gearmotors
  - Brake motors
  - Drives for overhead trolley systems
  - Geared torque motors
  - Pole-changing gearmotors
  - Aseptic gearmotors
  
- Electronically controlled drives with
  - MOVITRAC® frequency inverters
  - MOVIDRIVE® drive inverters
  - MOVIDYN® servo controllers
  - Technology and communication options for the inverters
  - Asynchronous AC motors and AC gearmotors
  - Asynchronous and synchronous servomotors and geared servomotors
  - DC motors, brake motors and gearmotors
  - Synchronous and asynchronous linear motors
  
- Components for decentralized installation
  - MOVIMOT® gearmotors with integrated frequency inverter
  - MOVI-SWITCH® gearmotors with integrated switching and protection function
  - Field distributors, fieldbus interfaces



- Mechanical variable speed drives
  - VARIBLOC® wide V-belt variable speed gearmotors
  - VARIMOT® friction disc variable speed gearmotors
  
- Explosion-proof drives to ATEX 100a for category 2 and category 3
  
- Services
  - Technical consulting
  - Application software
  - Seminars and training
  - Extensive technical documentation
  - Worldwide customer service

### ***Content of the catalog***

This catalog describes VARIBLOC® and VARIMOT® variable speed gearmotors. It contains project planning notes, mounting positions, technical data, selection tables and dimension sheets for standard variable speed gearmotors.

The catalog also provides notes on using variable speed gearmotors in potentially explosive atmospheres.

Please refer to separate catalogs for information about other SEW products:

### ***Other catalogs***

- Gearmotors
- Gear units
- Low backlash planetary gear units
- Geared servomotors
- Pole-changing gearmotors
- Drives for overhead trolley systems
- Explosion-proof drives
- MOVIMOT® Gearmotors
- Compact gear units
- Planetary gearmotors
- DAS Aseptic drives