

## 13 AC motors DT56, DR63

### 13.1 Technical data DT56, DR63

#### 13.1.1 3000 rpm - S1

Motor type	$P_N$ $M_N$	$n_N$	$I_N$ 380-415 V (400 V)	$\cos\phi$	$I_A/I_N$	$M_A/M_N$ $M_H/M_N$	$J_{Mot}$		$Z_0$	$M_{Bmax}$	$m^1$	
	kW Nm	rpm	A				2)	3)	BG <sup>4)</sup> BGE <sup>5)</sup>	Nm	kg	
							$10^{-4} \text{ kgm}^2$		1/h			
DR63S2	0.18 0.63	2720	12:46 AM (0.45)	0.88	4.2	2.4 2.2	3.6	4.8	5000 -	1.6	6.2	8.0
DR63M2	0.25 0.9	2660	0.66 (0.65)	0.86	3.5	2.2 1.9	3.6	4.8	4500 -	2.4	6.2	8.0
DR63L2	0.37 1.3	2650	1.0 (0.92)	0.87	3.5	2.1 1.9	4.4	5.6	4000 -	3.2	6.7	8.5

1) applies to flange motor

2) without brake

3) with brake

4) operation with BG brake control

5) operation with BGE brake control

#### 13.1.2 1500 rpm - S1

Motor type	$P_N$ $M_N$	$n_N$	$I_N$ 380-415 V (400 V)	$\cos\phi$	$I_A/I_N$	$M_A/M_N$ $M_H/M_N$	$J_{Mot}$		$Z_0$	$M_{Bmax}$	$m^1$	
	kW Nm	rpm	A				2)	3)	BG <sup>4)</sup> BGE <sup>5)</sup>	Nm	2)	3)
							$10^{-4} \text{ kgm}^2$		1/h		kg	
DT56M4	0.09 0.66	1300	0.31 (0.29)	0.68	2.6	2.1 1.8	1.1	1.2	10000 -	0.8	Only in combination with helical gear units R07, RF07, R07F or SPIROPLAN® gear units W10, WF10, WA10, WAF10	
DT56L4	0.12 0.88	1300	0.46 (0.42)	0.68	2.6	2.2 1.9	1.1	1.2	10000 -	1.2		
DR63S4	0.12 0.83	1380	0.39 (0.39)	0.69	3.3	2.4 2.2	3.6	4.8	10000 -	2.4	6.1	7.6
DR63M4	0.18 1.3	1320	0.55 (0.55)	0.78	2.9	1.8 1.7	3.6	4.8	10000 -	3.2	6.1	7.6
DR63L4	0.25 1.8	1300	0.73 (0.68)	0.81	2.8	1.8 1.7	4.4	5.6	10000 -	3.2	6.7	8.2

1) applies to flange motor

2) without brake

3) with brake

4) operation with BG brake control

5) operation with BGE brake control

## 13.1.3 1000 rpm - S1

Motor type	P <sub>N</sub>	M <sub>N</sub>	n <sub>N</sub>	I <sub>N</sub> 380-415 V (400 V)	cosφ	I <sub>A</sub> /I <sub>N</sub>	M <sub>A</sub> /M <sub>N</sub> M <sub>H</sub> /M <sub>N</sub>	J <sub>Mot</sub>		Z <sub>0</sub>	M <sub>Bmax</sub>	m <sup>1)</sup>	
	kW	Nm	rpm	A				2)	3)	BG <sup>4)</sup> BGE <sup>5)</sup>	Nm	kg	
								10 <sup>-4</sup> kgm <sup>2</sup>		1/h			
DR63S6	0.09	0.95	900	0.42 (0.38)	0.64	2.2	1.8 1.6	5.4	6.6	20000 -	2.5	6.0	7.5
DR63M6	0.12	1.2	900	0.62 (0.58)	0.65	2.1	1.8 1.7	5.4	6.6	20000 -	3.2	6.0	7.5
DR63L6	0.18	2	870	0.81 (0.78)	0.70	2.2	1.6 1.5	6.8	8.0	20000 -	3.2	6.6	8.1

1) applies to flange motor

2) without brake

3) with brake

4) operation with BG brake control

5) operation with BGE brake control

## 13.2 General notes on the product description

### 13.2.1 Noise

The noise levels of all motors from SEW-EURODRIVE are well within the maximum permitted noise levels set forth in IEC/EN 60034-9.

### 13.2.2 Painting

The motors from SEW-EURODRIVE are painted with "blue/gray" / RAL 7031 machine paint according to DIN 1843 as standard. Special coatings are available on request.

### 13.2.3 Surface and anti-corrosion protection

If required, all motors from SEW-EURODRIVE can also be supplied with special surface protection for applications in extremely humid and chemically aggressive environments.

### 13.2.4 Air admission and accessibility

The motors/brakemotors must be mounted on the driven machine in such a way that sufficient space, both axially and radially, is left for unimpeded air admission and for maintenance of the brake. Please also refer to the notes in the motor dimension sheets.

### 13.2.5 Brakemotors

On request, the motors can be supplied with an integrated mechanical brake. The SEW-EURODRIVE brake is an electromagnetic disk brake with a DC coil that releases electrically and brakes using spring force. Due to its operating principle, the brake is applied if the power fails. It meets the basic safety requirements. The brake can also be released mechanically if equipped with manual brake release. For this purpose, the brake is supplied with either a hand lever with automatic reset or an adjustable set screw. The brake is controlled with a brake control that is either installed in the motor wiring space or the control cabinet.

A characteristic feature of the brakes is their very short design. The brake endshield is a part of both the motor and the brake. The integrated construction of the SEW-EURODRIVE brakemotor permits particularly compact and sturdy solutions.

### 13.2.6 International markets

On request, SEW-EURODRIVE supplies UL-registered motors or CSA certified motors with connection conditions according to CSA and NEMA standard.

For the Japanese market, SEW-EURODRIVE offers motors conforming to JIS standard. Please contact SEW-EURODRIVE if required.

### 13.3 Special markets

#### 13.3.1 CSA/NEMA/UL-R

SEW-EURODRIVE offers the NEMA MG1 version or the CSA/UL-R option for drives delivered to North America. These versions have the following characteristic features:

- Terminal designation T1, T2, etc. in addition to U1, V1, etc.
- The terminal boxes are part of the motor housing.
- Cable entry in the terminal box compliant with ANSI/ASME B1.20.1.-1983 with NPT threads (conical inch threads). The following table shows the number of cable entries and NPT sizes for the respective motor sizes.

Motor size	Number and type of threads
DT56	1 × 1/2" NPT + 1 × 3/8" NPT (with adapter)
DR63	2 × 1/2" NPT (with adapter)

The NPT openings are sealed with plugs for transportation and storage.

- For AC motors/AC brakemotors modified nameplate with the following information: TEFC, K.V.A. code and design. With CSA/UL-R option also CSA and UR mark (UL registration no. E189357).

Exemplary representation of a nameplate:

<b>SEW-EURODRIVE</b>		CE	NR11/1	UL	E189357
76646 Bruchsal / Germany					
Type	DFT90L4 / BMG	Amb. °C		40	3 Phase
No.	3001123456.001.00				
rpm	1720				
○ kW	1.5 S1	K.V.A.-Code		K	○
V	230 YY / 460 Y	A	6.2 / 3.1	Hz	60
Duty	CONT.	kg	18	Ins.Cl.	F
Power fact.	0.76	IM	B5	M.L.	2
		Eff %	81	Design	C
Brake	V 230 AC Nm 20	Rectifier	BG1.5		
		181 877 5.C1		Made in Germany	

4174649099

#### 13.3.2 JIS/JEC

The drives can be built according to JIS for delivery to Japan. SEW-EURODRIVE supplies special motor terminal boxes on request. These terminal boxes have cable entries with the PF threads (straight inch thread) customary in Japan.

#### 13.3.3 V.I.K.

The German association of the Energy and Power Generation Industry V.I.K. has published for its members a recommendation for the implementation of technical requirements for AC asynchronous motors.

The drives from SEW-EURODRIVE can be supplied in compliance with these requirements. In this case, please contact SEW-EURODRIVE.

#### 13.3.4 CCC

After joining the World Trade Organization (WTO), the People's Republic of China issued a certification system – CCC "China Compulsory Certification" – for products. CCC became effective on 1 May 2002 and replaced the marks "Great Wall" (CCEE China Commission for Conformity of Electric Equipment) for domestic products and

"CCIB" (China Commodity Inspection Bureau) for imported products. The Chinese government introduced the CCC certification in order to improve the safety of household appliances. The certification requirement became effective on August 1, 2003 for many products in household applications.

As a result, machines and systems of our customers with permanently installed motors and gearmotors are usually not subject to this mandatory certification. The only known exceptions are welding machines. Therefore, for the mechanical and plant engineering sector, CCC certification will only be relevant for individually exported products, such as spare parts.

This certification also affects SEW-EURORDRIVE products. The drive solutions from SEW-EURODRIVE obtained the necessary certification on July 29, 2003.

### 13.4 Corrosion and surface protection

See chapter "Corrosion and surface protection" (→  57).

## 13.5 Type designation for AC motors and options

### 13.5.1 Standard AC motor in the series

DR.., DT..	Attached motor for gear units
DFR..	Flange-mounted design

### 13.5.2 Motor options

/BR, /BMG	Brake (reduced noise)
../HF	.. with lock-type manual brake release
../HR	.. with automatic manual brake release
/RS	Backstop
/TF	Thermistor (PTC resistor)
/TH	Thermostat (bimetallic switch)
/U	non-ventilated
/C	Protection canopy for fan guard

### 13.5.3 Plug connector options on DR63 AC motor

/IS	Integrated plug connector
/AMD..	Han® modular 10B plug connector on terminal box with single locking latch
/AME..	Han® modular 10B plug connector on terminal box, single locking latch and EMC housing
/ASD..	Han® 10ES plug connector on terminal box, single locking latch
/ASE..	Han® 10ES plug connector on terminal box, single locking latch and EMC housing

### 13.5.4 Encoder options on DR63 AC motor

/EH1S	Encoder with hollow shaft, sin/cos signals
/EH1T	Encoder with hollow shaft, TTL (RS422) signals
/EH1R	Encoder with hollow shaft, TTL (RS422) signals, $U_B = 9 - 26 \text{ V}$
EH1C	Encoder with hollow shaft, HTL signals

## 13.6 Important order information

### 13.6.1 Position of motor terminal box and cable entry

To date, the position of the motor terminal box has been specified as 0°, 90°, 180° or 270° as viewed onto the fan guard = B-side. A change in the product standard EN 60034 specifies that the following designations must be used for terminal box positions for foot-mounted motors in the future:

- As viewed onto the output shaft = A-side
- Designation as R (right), B (bottom), L (left) and T (top)

This new designation applies to foot-mounted motors without a gear unit in mounting position B3 (= M1). The previous designation is retained for gearmotors. The following figure shows both designations. Where the mounting position of the motor changes, R, B, L and T are rotated accordingly. In motor mounting position B8 (= M3), T is at the bottom.

The position of the cable entry can be selected as well. Available positions are "X" (= standard position), "1", "2" or "3".

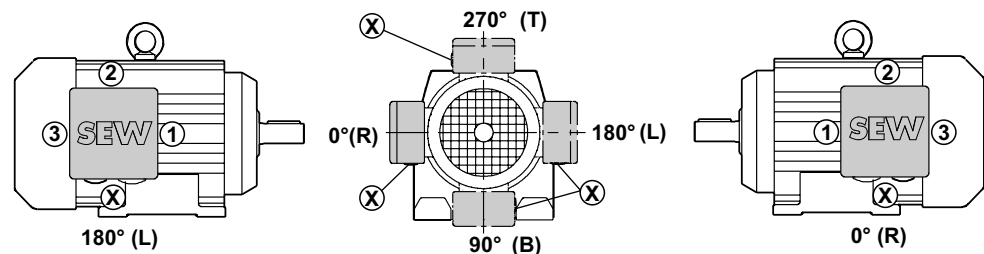

4174879627

Unless indicated otherwise, terminal box type 0° (R) with cable entry "X" will be supplied. We recommend selecting cable entry "2" with mounting position M3.

## INFORMATION



When the **terminal box is in the 90° (B)** position, check to see if the gearmotor needs to be supported.

**Only** cable entries "X" and "2" are possible with **DT56 and DR63** motors. **Exception: Cable entry "3" is also possible for DR63 with IS plug connector.**

Terminal box position	0° (R)	90° (B)	180° (L)	270° (T)
Possible cable entries	"X", "3"	"X", "1", "3"	"1", "2"	"X", "1", "3"

## 13.7 Mounting position designations of motors

See chapter "Mounting Positions" (→ 144).

## 13.8 Available motor options

### 13.8.1 Overview

The following motor options are available in various combinations:

- BMG02, BR03 (→ 641) disk brakes
- IS integrated plug connector (→ 621)
- AS., AC., AM., AB.. (→ 623) plug connectors
- Encoders and prefabricated cables for encoder connection (→ 627)
- Protection canopy C (→ 633)

## 13.9 Standards and regulations

### 13.9.1 Conformance to standards

AC motors and AC brakemotors from SEW-EURODRIVE conform to the relevant standards and regulations, in particular:

- IEC 60034-1, EN 60034-1

Rotating electrical machinery, rating and performance.

- EN 60529

IP degrees of protection provided by electrical equipment housing.

- IEC 60072

Dimensions and performance of rotating electrical machinery.

- EN 50262

Metric threads of cable glands.

- EN 50347

Standardized dimensions and power ranges.

### 13.9.2 Rated data

See section "Rated data" (→ 17).

### 13.9.3 Tolerances

See section "Tolerances" (→ 18).



## 13.10 Electrical characteristics

### 13.10.1 Inverter-compatible

AC (brake) motors can be operated on inverters, for example SEW-EURODRIVE MOVIDRIVE®, MOVITRAC® and MOVIMOT®, thanks to the high quality of insulation (including phase separator) with which they are equipped as standard.

### 13.10.2 Frequency

SEW-EURODRIVE AC motors are designed for a 50 Hz or 60 Hz line frequency on request. By default, the technical data for AC motors refers to a 50 Hz line frequency.

### 13.10.3 Motor voltage

AC motors are available for nominal voltages from 220 – 690 V. Pole-changing motors of size 63 only from 220 – 500 V.

The standard version for motor sizes 250/280 is AC 380 – 415/660 – 690 V, 50 Hz. The star or delta jumpers are mounted on the terminal board.

#### For 50 Hz power supply

The standards voltages are:

Motors	Motor size	
	DT56	DR63
	Motor voltage	
Single-speed	-	230/400 V <sub>AC</sub> Δ / Y 290/500 V <sub>AC</sub> Δ / Y
	Brake voltage	
Standard voltages	24 V <sub>DC</sub> / 230 V <sub>AC</sub> / 400 V <sub>AC</sub>	

Motors and brakes for AC 230/400 V and motors for AC 690 V may also be operated on supply systems with a nominal voltage of AC 220/380 V or AC 660 V respectively. In this case, the voltage-dependent data will change slightly.

#### Standard connections 50 Hz motors

Number of poles	Synchronous speed $n_{syn}$ at 50 Hz in rpm	Connection
2	3000	Y / Δ
4	1500	Y ; Y / Δ
6	1000	Y / Δ

#### 50 Hz motor on 60 Hz supply system

The rated data of motors designed for 50 Hz supply systems is slightly different when the motors are operated on 60 Hz supply systems:

Motor voltage at 50 Hz	Motor connection	U in V at 60 Hz	Modified rated data			
			$n_N$	$P_N$	$M_N$	$M_A/M_N$
230/400 V <sub>AC</sub> Δ/Y	Δ	230	+20%	0%	-17%	-17%

19290411/EN – 10/2014

Motor voltage at 50 Hz	Motor connection	U in V at 60 Hz	Modified rated data			
			$n_N$	$P_N$	$M_N$	$M_A/M_N$
230/400 V <sub>AC</sub> Δ/∩	∩	460	+20%	+20%	0%	0%
400/690 V <sub>AC</sub> Δ/∩	Δ					

### For 60 Hz power supply

The **standard voltages** are indicated in **bold**:

Motors	Motor size	
	56	63
	Motor voltage	
Single-speed	-	<b>266/460V</b> <sub>AC</sub> Δ/∩ 220/380 V <sub>AC</sub> Δ/∩ 330/575 V <sub>AC</sub> Δ/∩
	Brake voltage	
Standard voltages	24 V <sub>DC</sub> / 230 V <sub>AC</sub> / 266 V <sub>AC</sub> / 460 V <sub>AC</sub>	

### Standard connections 60 Hz motors

Number of poles	Synchronous speed $n_{syn}$ at 60 Hz in rpm	Connection
2	3600	Δ/∩ ; ∩∩ / ∩
4	1800	
6	1200	

### 60 Hz motor on 50 Hz supply system

The rated data of motors designed for 50 Hz supply systems is slightly different when the motors are operated on 60 Hz supply systems.

**Example:** NEMA C-motor, designed for the USA, operation on a 50 Hz supply system:

Motor voltage at 60 Hz (USA)	Motor connection	U in V at 50 Hz	Modified rated data			
			$n_N$	$P_N$	$M_N$	$M_A/M_N$
230/460 V <sub>AC</sub> ∩∩ / ∩	∩	400	-17%	-17%	0%	0%

#### 13.10.4 Motors for the USA and Canada

Motors for the USA and Canada are designed according to NEMA or CSA regulations. NEMA or CSA single speed motors are registered by Underwriters Laboratories (UL). The following voltage assignments (60 Hz) are customary in the USA and Canada:

	Nominal voltage of the supply power	Nominal voltage of the motor
USA	208 V	200 V
	240 V	230 V
	480 V	460 V

	Nominal voltage of the supply power	Nominal voltage of the motor
Canada	600 V	575 V

The motor voltage may deviate up to  $\pm 10\%$  from the nominal voltage. This deviation largely corresponds to the tolerance B.

In the USA, it is normal for AC 230/460 V / 60 Hz motors to be used.

### 13.11 Circuit breaker and protective equipment

See chapter "General project planning notes" (→ 77).

#### 13.11.1 Safe switching of inductances

Note the following information for the switching of inductances:

- Switching of low-speed motor windings.

If the cable is routed incorrectly, switching of low-speed motor windings can generate voltage peaks. Voltage peaks can damage windings and contacts. Install varistors in the incoming cable to avoid such problems.

- Switching of brake coils.

Varistors must be used to avoid harmful switching overvoltages caused by switching operations in the DC circuit of disk brakes.

Brake control systems from SEW-EURODRIVE are equipped with varistors as standard. Use contactors with contacts in utilization category AC3 or better to EN 60947-4-1 for switching of brake coils.

- Suppressor circuit on the switching devices.

According to EN 60204 (Electrical Equipment of Machines), motor windings must be equipped with interference suppression to protect the numerical or programmable logic controllers. Because problems are primarily caused by switching operations, SEW-EURODRIVE recommends installing suppressor circuits on the switching devices.

### 13.12 Thermal characteristics

#### 13.12.1 Thermal classes according to IEC 60034-1 (EN 60034-1)

- The single-speed AC motors DT56 and DR63 are designed in thermal class 130 (B) as standard. Thermal classes 155 (F) or 180 (H) are available on request.

The table below lists the overtemperatures to IEC 60034-1 (EN 60034-1).

Thermal classes		Limit overtemperature in K
New	Old	
130	B	80 K
155	F	105 K
180	H	125 K

#### 13.12.2 Power reduction

The rated power  $P_N$  of an AC motor or the thermally permitted torque  $M_N$  of an asynchronous servomotor is dependent on the ambient temperature and the installation altitude. The rated power or rated torque stated on the nameplate applies to an ambient temperature of 40°C and a maximum installation altitude of 1000 m above sea level. The rated power or rated torque must be reduced according to the following formula in the case of higher ambient temperatures or installation altitudes:

$$P_{Nred} = P_N \cdot f_T \cdot f_H$$

$$M_{Nred} = M_N \cdot f_T \cdot f_H$$

### AC motors

Refer to the following diagrams for factors  $f_T$  and  $f_H$  for AC motors:

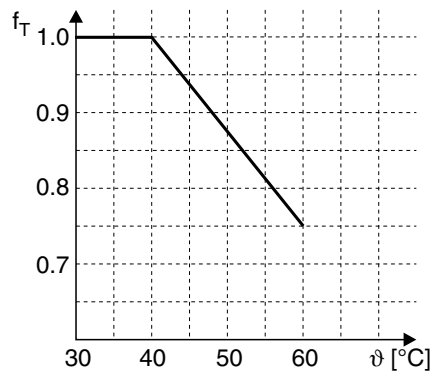

4175931659

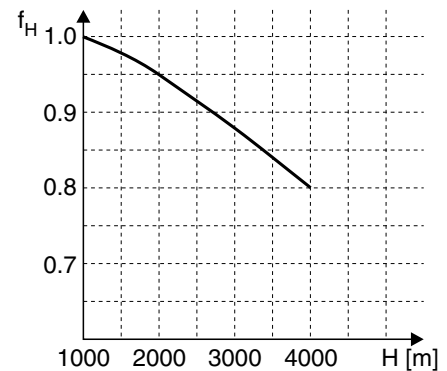

4175931659

$\vartheta$  = ambient temperature

$H$  = installation altitude above sea level

#### 13.12.3 Operating modes

See section "Operating modes" (→ 131).

### 13.13 Starting frequency

See chapter "Starting frequency" (→  137).

#### 13.13.1 Permitted work done by the brake

If you are using a brakemotor, you must check whether the brake is approved for use with the required starting frequency Z.

### 13.14 Mechanical characteristics

See chapter "Mechanical characteristics" (→ 139).

### 13.15 Overhung loads and axial forces

The following table lists the permitted overhung loads (top value) and axial forces (bottom value) of DR63 AC motors:

Mounting position	Speed in rpm Number of poles	Permitted overhung load $F_R$ in N
		Permitted axial load $F_A$ in N; $F_{A\_tensile} = F_{A\_pressure}$
Flange-mounted motor	1000	600
	6	150
	1500	500
	4	110
	3000	400
	2	70

#### 13.15.1 Overhung load conversion for off-center force application

The permitted overhung loads must be calculated using the following formulae in the event of force application not in the center of the shaft end. The smaller of the two values  $F_{xL}$  (according to bearing service life) and  $F_{xw}$  (according to shaft strength) is the permitted value for the overhung load at point x.

All overhung load diagrams are based on a bearing service life of 20,000 hours. A detailed bearing service life calculation is available on request. Note that the calculations apply to  $M_N$ .

#### $F_{xL}$ based on bearing service life

$$F_{xL} = F_R \cdot \frac{a}{b + x} \text{ [N]}$$

4175970827

### $F_{xW}$ based on shaft strength

$$F_{xW} = \frac{c}{f + x} \text{ [N]}$$

4175973515

$F_R$  = Permitted overhung load ( $x = l/2$ ) in N

$x$  = Distance from the shaft shoulder to the force application point in mm

$a, b, f$  = Motor constants for overhung load conversion in mm

$c$  = Motor constant for overhung load conversion in Nmm

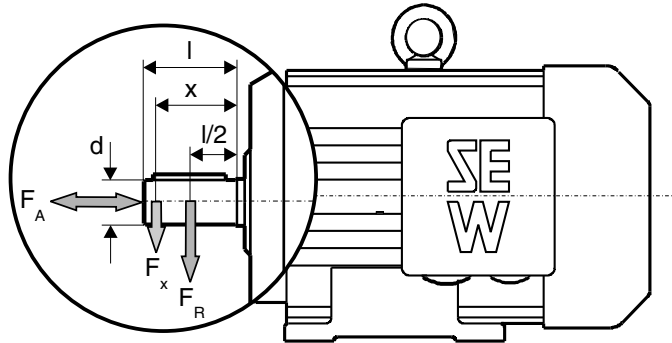

4175975179

### Motor constants for overhung load conversion

Motor type	a mm	b mm	c			f mm	d mm	l mm
			2-pole Nmm	4-pole Nmm	6-pole Nmm			
63	161	146	$11.2 \cdot 10^3$	$16.8 \cdot 10^3$	$19 \cdot 10^3$	13	14	30

### 2nd motor shaft end

Contact SEW-EURODRIVE regarding the permitted load for the 2nd motor shaft end.

### Motor bearings used

The following table shows which bearings are used in SEW-EURODRIVE AC (brake)motors:

Motor type	A-side bearing			B-side bearing	
	Flange-mounted motor	Gearmotor	Foot-mounted motor	Without brake	With brake
56	-	6302-Z	-	6001-2RS-J	
63	6203-2Z-J	6303-2Z-J	-	6202-2Z-J	6202-2RS-J-C3

19290411/EN – 10/2014



## 13.16 Project planning, technical data – plug connectors

### 13.16.1 Contact rating depending on the temperature

The "Technical data" tables for plug connectors lists electrical current values for the maximum permitted contact load (= max. contact load) of the plug connectors. These current values are valid for ambient temperatures of up to max. 40 °C. Higher ambient temperatures apply for reduced current values. The following graph shows the permitted contact load as a function of the ambient temperature.

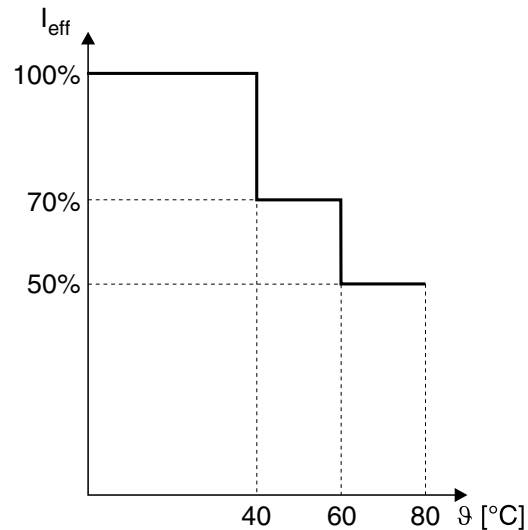

4176109195

$I_{\text{eff}}$  = Current value of the maximum permitted contact load, 100% = value as listed in the "Technical Data", from (→ 624)

$\vartheta$  = Ambient temperature

### 13.16.2 IS integrated plug connector

AC gearmotor with integrated IS plug connector

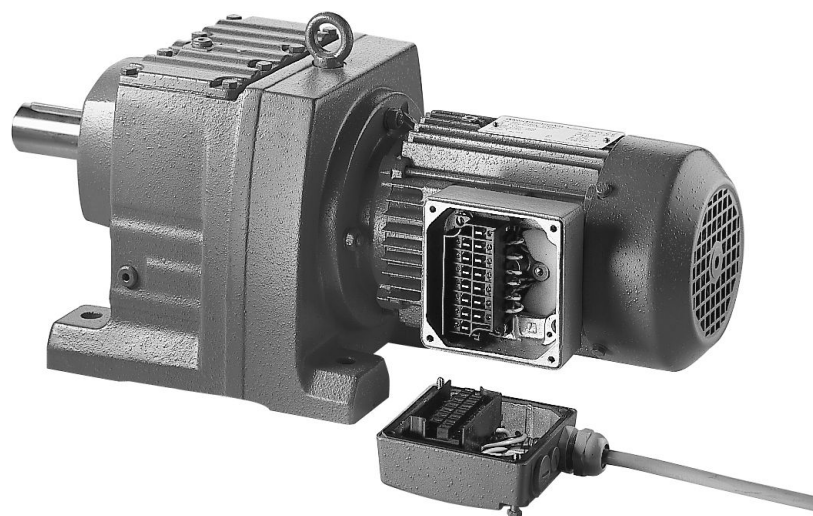

4176111883

The AC (brake)motors of the DR63 series can be supplied on request with the integrated 12-pole IS plug connector instead of the standard terminal box. The upper section of the IS plug connector (mating connector) is included in the scope of delivery. The IS plug connector is particularly compact and offers the following connection options:

- Motor, single-speed or two-pole multi-speed
- Brakes
- Temperature monitoring (TF or TH)

As with the terminal box, the cable entry for the IS integrated plug connector can also be from four different directions offset at 90°.

## INFORMATION



IS requires a clearance of 30 mm for removing the connector.

**For DR63 brakemotors with IS size 1 only:** Only brake control systems BG1.2, BG2.4, BSR and BUR can be accommodated in the IS. Other brake control systems must be installed in the control cabinet.

---

## 13.16.3 Plug connectors AS.., AC.., AM.., AB..

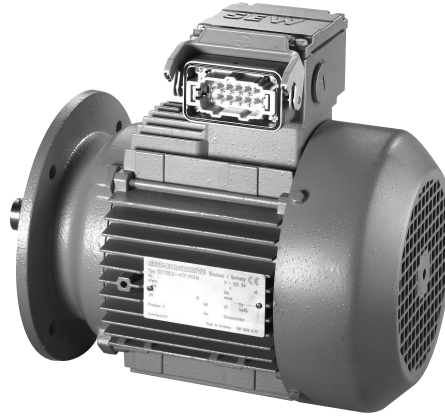

4176116235

The plug connector systems AS.., AC.., AM.., AB.. are based on plug connector systems from Harting.

- AS.., AC.. → Han® 10ES / 10E
- AM.., AB.. → Han® Modular

The plug connectors are located at the side of the terminal box. They are locked either using two clamps or one clamp on the terminal box.

UL approval has been granted for the plug connectors.

**The mating connector (sleeve housing) with socket contacts is not included in the scope of delivery.**

## AS.., AC..

The ten contacts of the AS.. and AC.. plug connector systems connect the motor winding (6 contacts), the brake (2 contacts) and the thermal motor protection (2 contacts). You can connect both motors with single speed and 2-pole multi-speed motors.

Types AS.. and AC.. differ as follows:

- AS = Cage clamps
- AC = Crimp contacts and shortened contacts for thermal motor protection

## INFORMATION



Applies to AS.1 and AC.1

With brakemotors, it is only possible to select the version with brake control in the terminal box. In this case, the disconnection in the DC circuit has to take place electronically using BSR or BUR.



The ASD.. and ASE.. types with single clip longitudinal closure correspond to the DE-SINA regulation issued by the Association of German Machine Tool Manufacturers (VDW).

**AM.., AB..**

Plug connectors AM.. and AB.. can be used for connecting both single-speed motors and two-speed pole-changing motors.

With brakemotors, the brake control system can be located either in the terminal box or in the control cabinet. All versions of the brake control system are possible.

**13.16.4 Prefabricated cable**

SEW-EURODRIVE provides a prefabricated cable for connecting the field distributor and the AC (brake) motor with option APG4. The cable is prefabricated in half-meter steps up to a maximum length of five meters. The cable can be ordered from SEW-EURODRIVE. Specify the required length (max. 5 m).

**13.16.5 IS integrated plug connector****Technical data**

IS size		1
For motors		DR63
Number of contacts		12 + 2 × PE
Contact connection		Screw connection
Contact type		Blade/bushing
Max. voltage/(CSA)	$V_{AC}$	690 / (600)
Max. contact rating	$A_{eff}$	16
Degree of protection		Corresponding to motor degree of protection (IP54, IP55, optionally IP56, IP65, IP66)
Ambient temperature	°C	-40 to +40

## 13.16.6 Installed plug connectors AS.., AM..

## Technical data AS..

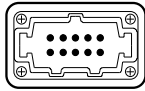
Plug connectors		ASD..
For motors		DR63
Locking of mating connector		Single clamp
Connector viewed from motor end		
Basic connector system		<sup>1)</sup>
Number of contacts		10
Max. contact rating	$A_{\text{eff}}$	10 × 16
PE connection		2 contacts on insulator
Max. voltage/(CSA)	$V_{\text{AC}}$	500/(600)
Contact connection		AC = crimp contacts (Han <sup>®</sup> 10E) AS.= cage clamps (HAN <sup>®</sup> 10ES)
Contact type		Pin/(socket = customer end)
Degree of protection		Corresponding to motor degree of protection (IP54, IP55, optionally IP65)
Ambient temperature	°C	-40 to +40

1) Harting, aluminum standard housing (painted) Han<sup>®</sup> 10E/10ES

## Technical data AM..

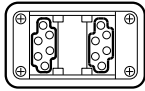
Plug connectors		AMD..
For motors		DR63
Locking of mating connector		Single clamp
Connector viewed from motor end		
Basic connector system		<sup>1)</sup>
Number of contacts		2 × 6
Module type <sup>2)</sup>		2 × E-module
Max. contact rating	$A_{\text{eff}}$	12 × 16
PE connection		2 contacts on articulated frame
Max. voltage/(CSA)	$V_{\text{AC}}$	500/(600)
Contact connection		Crimp contacts
Contact type		Pin/(socket = customer end)
Degree of protection		Corresponding to motor degree of protection (IP54, IP55, optionally IP65)
Ambient temperature	°C	-40 to +40

1) Harting, standard aluminum housing (painted) Han Modular® 10B

2) The module type depends on the current. C-module for more than 16 A, E-module for less than or equal to 16 A.

## 13.17 Project planning, technical data – encoders

### 13.17.1 Speed sensors

Various types of speed sensor are available for installation on DR63 AC motors as standard depending on the application and motor size.

#### Overview of encoders

Designation	Motor	Encoder type	Shaft	Specification	Supply	Signal
EH1T	DR63	Encoder	Hollow shaft	1024 pulses/revolution	5 V <sub>DC</sub> controlled	TTL/RS422
EH1S					9 V <sub>DC</sub> – 26 V <sub>DC</sub>	1 V <sub>SS</sub> sin/cos
EH1R						TTL/RS422
EH1C						HTL

#### Encoder connection

When connecting the encoders to the inverters, always follow the operating instructions for the relevant inverter and the wiring diagrams supplied with the encoders.

- The maximum cable length (inverter– encoder) is 100 m with a cable capacitance:
  - < 83 nF/km (conductor/conductor) according to DIN VDE 0472 part 504
  - < 110 nF/km (conductor/shield)
- Core cross section: 0.20 – 0.5 mm<sup>2</sup>
- Use shielded cable with twisted pair conductors and apply shield over large area on both ends:
  - To the encoder in the cable gland or in the encoder plug
  - To the inverter on the electronics shield clamp and/or to the housing of the D-sub connector
- Install the encoder cables separately from the power cables, maintaining a distance of at least 200 mm.
- Encoder with cable gland: Observe the permitted diameter of the encoder cable to ensure that the cable gland functions correctly.

### 13.17.2 Prefabricated cables for encoder connection

SEW-EURODRIVE offers prefabricated cables for simple and reliable connection of encoder systems. It is necessary to differentiate between cables used for fixed installation or for use in cable carriers. The cables are prefabricated in 1 m steps for the required length.

Prefabricated cables for encoder connection and encoders:

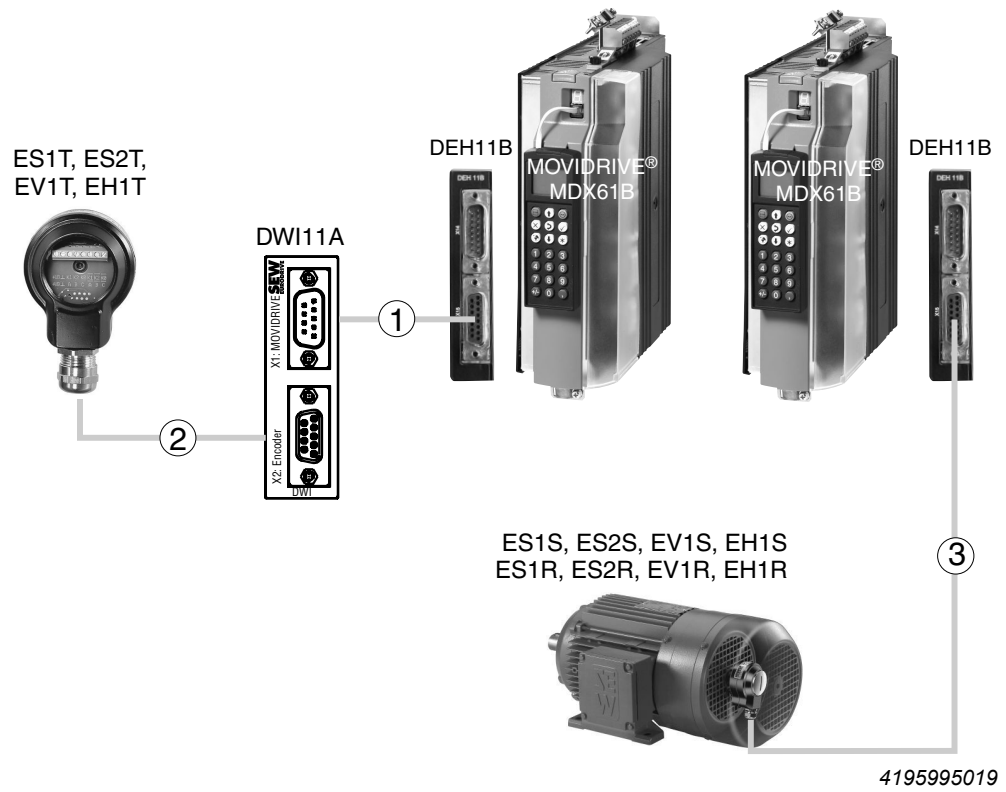



①

Prefabricated cables for encoder connection:

Part number	8179573
Installation	Fixed installation
For encoders with 5 V voltage supply	EH1T
Cable cross section	4×2×0.25 mm <sup>2</sup> (AWG23) + 1×0.25 mm <sup>2</sup> (AWG23)
Conductor colors	A: yellow (YE) A: green (GN) B: red (RD) B: blue (BU) C: pink (PK) C: gray (GY) UB: white (WH) ⊥: brown (BN) Sensor cable: violet (VT)
Manufacturer and type Lapp Helukabel	Unitronic Li2YCY (TP) Paar-Tronic-CY
For inverters	MOVIDRIVE® MDX61B with DEH11B option
Connection on the DWI11A on the inverter	with 9-pin D-sub socket with 15-pin D-sub connector

13

②

Prefabricated cables for incremental TTL rotary encoders with 5 V voltage supply:

Part number	1988298	198828X
Installation	Fixed installation	Cable carrier installation
For encoders	EH1T via DWI11A and cable 817 957 3	
Cable cross section	4×2×0.25 mm <sup>2</sup> (AWG23) + 1×0.25 mm <sup>2</sup> (AWG23)	
Conductor colors	A: yellow (YE) A: green (GN) B: red (RD) B: blue (BU) C: pink (PK) C: gray (GY) UB: white (WH) ⊥: brown (BN) Sensor cable: violet (VT)	
Manufacturer and type		
Lapp	Unitronic Li2YCY (TP)	Unitronic LiYCY
Helukabel	Paar-Tronic-CY	Super-Paar-Tronic-C-PUR
For inverters	MOVIDRIVE® MDX61B with DEH11B option	
Connection to encoder/motor	with conductor end sleeves Connect the violet conductor (VT) with the encoder at UB with 9-pin D-sub connector	

3

Prefabricated cables for incremental TTL sensors and sin/cos rotary encoders with 24 V voltage supply:

Part number	13324594	13324586
Installation	Fixed installation	Cable carrier installation
For encoders	EH1S, EH1R	
Cable cross section	4×2×0.25 mm <sup>2</sup> (AWG23) + 1×0.25 mm <sup>2</sup> (AWG23)	
Conductor colors	A: yellow (YE) A: green (GN) B: red (RD) B: blue (BU) C: pink (PK) C: gray (GY) UB: white (WH) ⊥: brown (BN) Sensor cable: violet (VT)	
Manufacturer and type		
Lapp	Unitronic Li2YCY (TP)	Unitronic LiYCY
Helukabel	Paar-Tronic-CY	Super-Paar-Tronic-C-PUR
For inverters	MOVIDRIVE® MDX61B with DEH11B option	
Connection to encoder/motor	with conductor end sleeves Cut off the violet conductor (VT) of the cable at the encoder end, with 15-pin D-sub connector	

13

## 13.17.3 Incremental rotary encoders

## Hollow shaft encoder

## Incremental encoder with 1024 pulses/revolution:

Hollow shaft encoders for DR63 AC motors		EH1T	EH1S <sup>1)</sup>	EH1R
Supply voltage	$U_B$	$5 V_{DC} \pm 5\%$	$9 V_{DC} - 26 V_{DC}$	
Max. current consumption	$I_{in}$	180 mA	160 mA	180 mA
Output amplitude per track	$U_{high}$ $U_{low}$	$\geq 2.5 V_{DC}$ $\leq 0.5 V_{DC}$	1 $V_{SS}$	$\geq 2.5 V_{DC}$ $\leq 0.5 V_{DC}$
Signal output		TTL/RS-422	Sin/cos	TTL/RS-422
Output current per track	$I_{out}$	20 mA	40 mA	20 mA
Max. pulse frequency	$f_{max}$	120 kHz		
Pulses (sine cycles) per A, B Revolution C		1024 1		
Pulse duty factor		1 : 1 $\pm 20\%$		
Phase angle A : B		$90^\circ \pm 20\%$		
Vibration resistance (10 Hz – 2000 Hz)		$\leq 100 \text{ m/s}^2$ (EN 60068-2-6)		
Shock resistance		$\leq 1000 \text{ m/s}^2$ (EN 60068-2-27)		
Ambient temperature $\vartheta_U$		$-30^\circ\text{C}$ to $+60^\circ\text{C}$ (EN 60721-3-3, class 3K3)		
Degree of protection		IP66 (EN 60529)		
Connection		Terminal box on encoder		

1) recommended encoder for operation with MOVIDRIVE®

## 13.18 Project planning, technical data – protection canopy C

### 13.18.1 Protection canopy C

Liquids and/or solid foreign objects can penetrate the air outlet openings of motors in a vertical mounting position with their input shaft pointing downwards. SEW-EURODRIVE offers the motor option "protection canopy C" for this purpose.

Explosion-proof AC motors and AC brakemotors in a vertical mounting position with their output shaft pointing downwards must always be ordered with protection canopy C. The same applies to motors in a vertical mounting position installed outdoors.

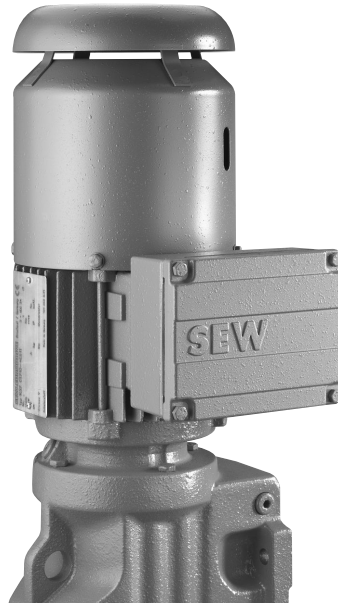

4200161419

13

## 13.19 Project planning for AC motors with inverters

Information can be found in the chapter "Drive selection – controlled motor" (→ 179).