



7 Important Information on Selection Tables and Dimension Sheets

7.1 Information on selection tables

Selection table

example

AM

$n_e = 1400$ rpm						820 Nm							
	i	n_a [rpm]	$M_{a \max}$ [Nm]	F_{Ra} [N]	φ (/R) [']	AM							
						63	71	80	90	100	112	132S/M	132ML
R77 2	5.31	264	510	3990	8								
	5.99	234	540	3990	8								
	6.79	206	580	3850	8								
	7.74	181	610	3940	8								
	8.59	163	630	4110	7								
	9.64	145	630	6300	7								
	10.88	129	660	6490	6								

7

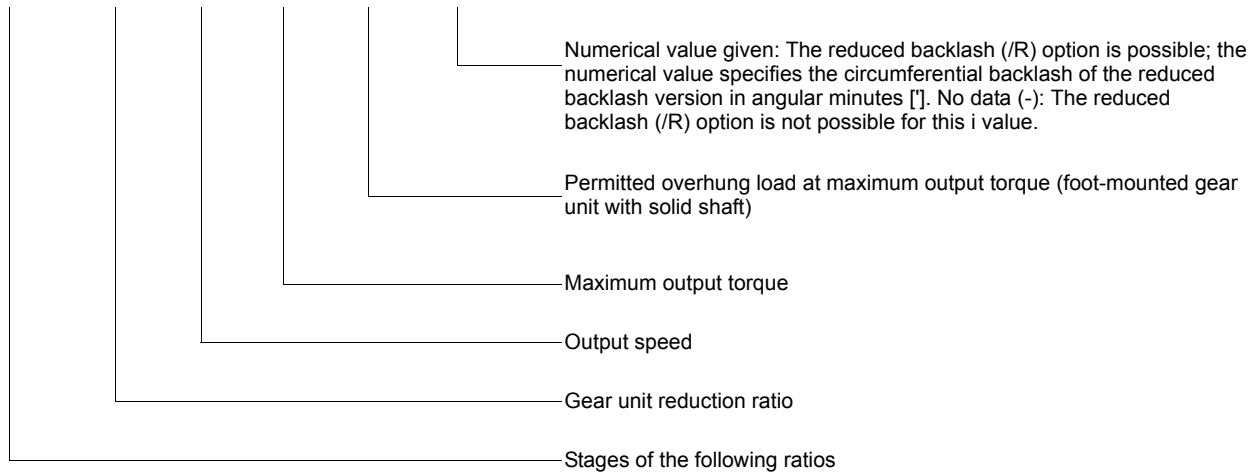

Note:

The following table shows the weight for gear units with IEC or NEMA adapter:

IEC	m [kg]		AM							
	R77	s	63	71	80	90	100	112	132S/M	132ML
	R77	2	33	34	36	36	40	40	47	47
	R77	3	34	35	37	37	41	41	48	48
NEMA			-	56	143	145	182	184	213/215	-
	R77	2	-	34	36	36	39	39	45	-
	R77	3	-	35	37	37	40	40	46	-

RF: + 5.7 kg / RM: + 30.7 kg

Key

- * Finite gear unit reduction ratio
- Combination is **possible**.
- Combination is **not possible**.
- Reference to the associated dimension sheet page number









Important Information on Selection Tables and Dimension Sheets

Information on selection tables

Sample selection table adapter AT



$n_e = 1400$ rpm:

		P_m [kW]				S_n [%]	
[1]	[2]	[3]	[4]	[5]	[6]	[7]	[8]

- [1] Gear unit size
- [2] Motor type
- [3] Motor power
- [4] Adapter type

- [5] Coupling type
- [6] Fill quantity [l]
- [7] Rated slip of the coupling
- [8] Dimension sheet page no.

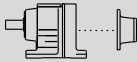
Selection table example AD

i	n_a [rpm]	$M_a \max$ [Nm]	P_e [kW]	F_{Ra} [N]	F_{Re} [N]	φ (/R) [°]			m [kg]		
R107 AD... , $n_e = 1400$ rpm										4300 Nm	
[1]	[2]	[3]	[4]	[5]	[6]	[7]	[8]	[9]	[10]	[11]	[12]

- [1] Gear unit reduction ratio
- [2] Output speed
- [3] Maximum permitted output torque
- [4] Calculated drive power of the gear unit
- [5] Permitted overhung load at maximum output torque (foot-mounted gear unit with solid shaft)
- [6] Permitted overhung load on the input side
- [7] Numerical value given: The reduced backlash (/R) option is possible; the numerical value specifies the circumferential backlash of the reduced backlash version in angular minutes [']. No data (-): The reduced backlash option (/R) is not possible for this i value.
- [8] Please observe chapter "Thermal limit power for gear units with input shaft assembly" (see page 66 and subsequent pages.)
- [9] Gear unit size
- [10] Cover type
- [11] Weight
- [12] Dimension sheet page number



7.2 Notes on the dimension sheets

Scope of delivery



= Standard parts supplied by SEW-EURODRIVE.



= Standard parts not supplied by SEW-EURODRIVE.

Tolerances

Shaft heights

The following tolerances apply to the indicated dimensions:

h	≤ 250 mm	→ -0.5 mm
h	> 250 mm	→ -1 mm

Foot-mounted gear units: Check the mounted motor because it may project below the mounting surface.

Shaft ends

Diameter tolerance:

∅	≤ 50 mm	→ ISO k6
∅	> 50 mm	→ ISO m6

Center bores according to standard 332, shape DR:

∅	= 7...10 mm	→ M3	∅	> 30...38 mm	→ M12
∅	> 10...13 mm	→ M4	∅	> 38...50 mm	→ M16
∅	> 13...16 mm	→ M5	∅	> 50...85 mm	→ M20
∅	> 16...21 mm	→ M6	∅	> 85...130 mm	→ M24
∅	> 21...24 mm	→ M8	∅	> 130 mm	→ M30
∅	> 24...30 mm	→ M10			

Keys: according to standard 6885 (domed type)

Hollow shafts

Diameter tolerance:

∅ → ISO H7 measured with plug gauge

Keys: according to standard 6885 (domed type)

Exception: Key for WA37 with shaft ∅ 25 mm according to standard 6885-3 (low type)

Multiple-spline shafts

Dm = Measuring roller diameter

Me = Check size

Flanges

Centering shoulder tolerance:

∅	≤ 230 mm (flange sizes A120...A300)	→ ISO j6
∅	> 230 mm (flange sizes A350...A660)	→ ISO h6

Up to 3 different flange dimensions are available for each size of helical gear units, SPIROPLAN® gear units, AC (brake) motors and explosion-proof AC (brake) motors. The respective dimension drawings will show the flanges approved for each size.



Eyebolts, suspension eye lugs

R07 - R27 helical gear units and SPIROPLAN® gearmotors W..10 to W..30 are delivered without special transportation fixtures. All other gear units and motors are equipped with cast-on suspension eye lugs, screw-on suspension eye lugs or screw-on lifting eyebolts.

Gear unit/motor type	Screw-on		Cast-on eyebolts
	lifting eyebolts	eyebolts	
RX57 - RX67	-	•	-
RX77 - RX107	•	-	-
R..37 - R..57	-	•	-
R..67 - R..167	•	-	-
F..27 - F..157	-	-	•
K..37 - K..157	-	-	•
K..167 - K..187	•	-	-
W..37, W..47	-	•	-
S..37 - S..47	-	•	-
S..57 - S..97	-	-	•

Breather valves

The gear unit dimension drawings always show the screw plugs. The corresponding screw plug is replaced by an activated breather valve at the factory depending on the ordered mounting position M1 to M6. The result may be slightly altered contour dimensions.

Shrink disk connection

Hollow shaft gear unit with shrink disk connection: If required, please request a detailed data sheet on shrink disks, data sheet no. 33 753 nn 95.

Splined hollow shaft

FV.. hollow shaft gear unit sizes 27 to 107, and KV.. sizes 37 to 107 are supplied with splining according to standard 5480.

Rubber buffer for FA/FH/FV/FT

Preload rubber buffer by the indicated value ΔL . The characteristic curve of spring for the rubber buffers is available at SEW-EURODRIVE on request.



Position of the arm

The following illustration shows the possible torque arm positions for helical-worm gear units and SPIROPLAN® gear units (135° position not possible with SPIROPLAN® gear units) as well as the respective angles:

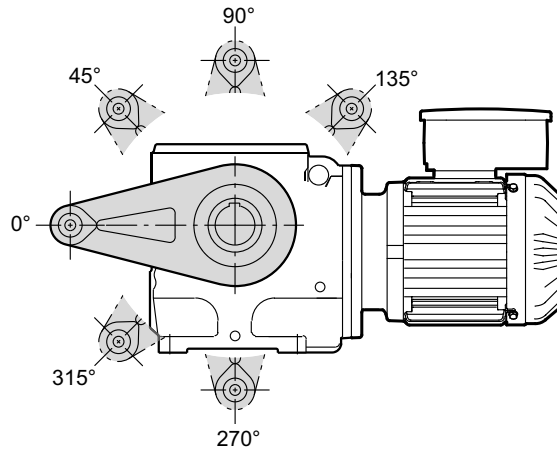

Figure 7: Position of the torque arm for S and W gear units

65930AXX

For information on torque arms for helical-worm gear units, refer to the dimension sheets from page 443, for specifications on torque arms for SPIROPLAN® gearmotors are found in the dimension sheets from page 520.

For specifications regarding torque arms for helical-bevel gear units, refer to page 353.

AD../P input shaft assembly with motor mounting platform

The following cases can arise with gear units with input shaft assemblies and motor mounting platforms:

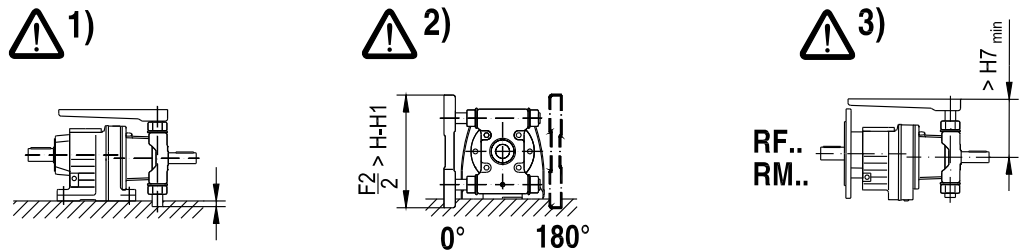

1. Depending on the setting, the column may protrude past the foot mounting surface
2. Motor mounting platform may protrude past the foot mounting surface
3. Motor mounting platform may collide with the gear unit flange, depending on the setting

The corresponding cases are indicated in the dimension tables in the following column:

E2	F2	G2	H6	H7 min	H7 max	H11 min	H11 max	K2	Q4	D1	L1	L13	L14	T1	U1	 →118
----	----	----	----	--------	--------	---------	---------	----	----	----	----	-----	-----	----	----	----------

53696AXX



7.3 Gear unit (garmotor) dimensions

Motor options

The motor dimensions may change when installing motor options. Refer to the dimension drawings of the motor options.

Special designs

The terminal box dimensions in special designs might vary from the standard.

EN 50347

European standard EN 50347 became effective in August 2001. This standard adopts the dimension designations for three-phase AC motors for sizes 56 to 315M and flange sizes 65 to 740 from the IEC 72-1 standard.

The new dimension designations given in EN 50347 / IEC 72-1 are used for the dimensions in question in the dimension tables of the dimensions sheets.

Gear unit dimensions

The dimensions of the gear units are described below:

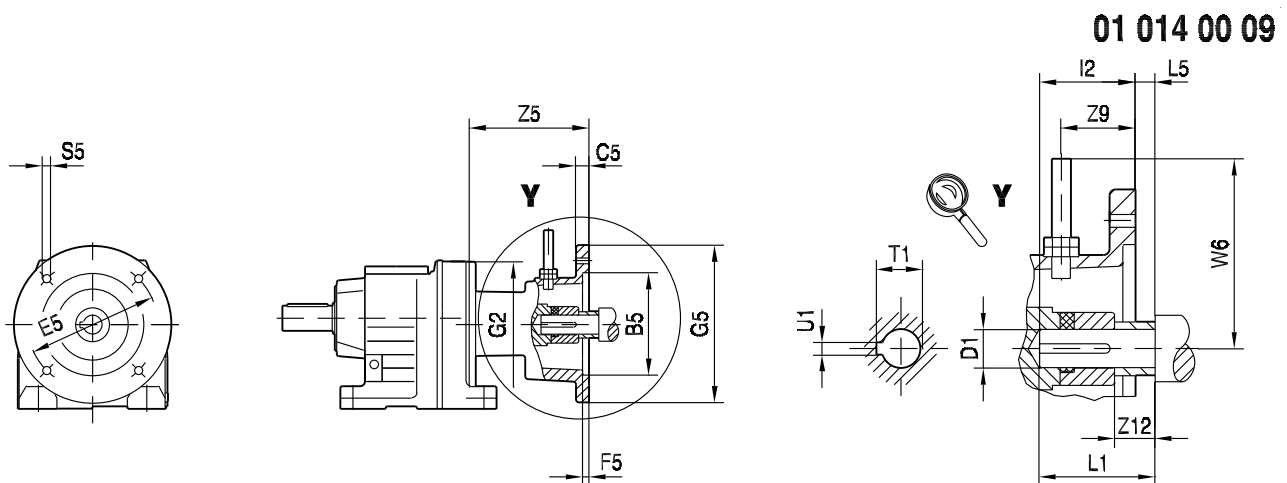

65973axx

G5	Adapter flange diameter	C5	Flange thickness
S5	Threaded hole	B5	Center bore diameter
E5	Hole circle diameter	F5	Centering depth
Z5	Adapter length	L1	Shaft end length (motor)
G2	Flange diameter of gear unit on input side	I2	Maximum insertion depth in adapter
D1	Coupling bore diameter	L5	Shaft collar length to flange surface
U1	Keyway width	Z9	Encoder position
T1	Keyway depth	W6	Encoder height
Z12	Shaft collar length to coupling		

INFORMATION



For motors with other feedback systems than resolvers, possible additional lengths must be considered.



AT../BMG

01 177 00 09

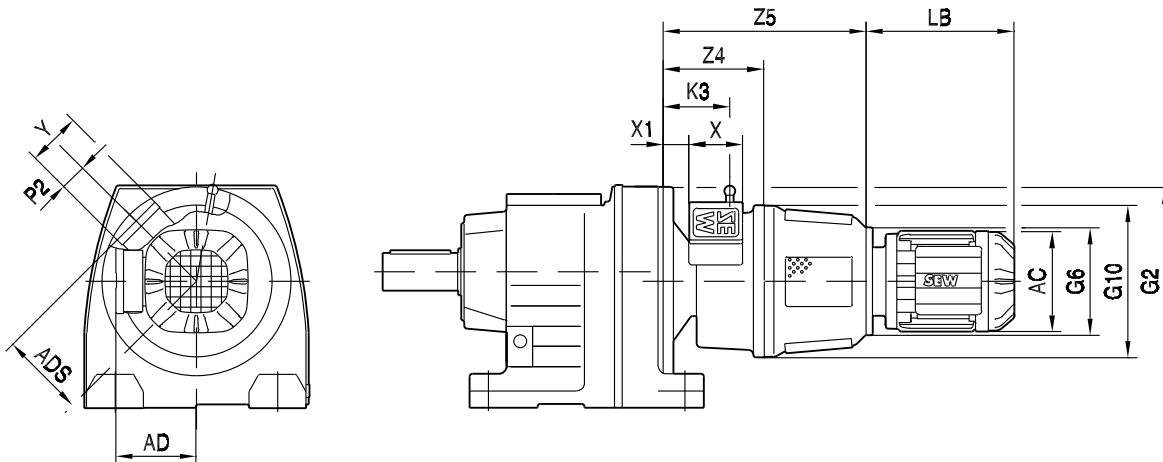

7

67785axx

- | | | | |
|----|------------------------------|-----|---|
| LB | Motor length | G10 | Housing diameter of centrifugal coupling |
| G6 | Motor flange diameter | Z4 | Distance between gear unit and hydraulic coupling |
| Z5 | Adapter length | X1 | Position of brake terminal box |
| K3 | Manual release position | P2 | Position of brake terminal box |
| X | Width of brake terminal box | ADS | Height of brake terminal box |
| Y | Length of brake terminal box | AD | Height of motor terminal box |
| AC | Motor diameter | | |



Important Information on Selection Tables and Dimension Sheets

Gear unit (gearmotor) dimensions

AD../ZR

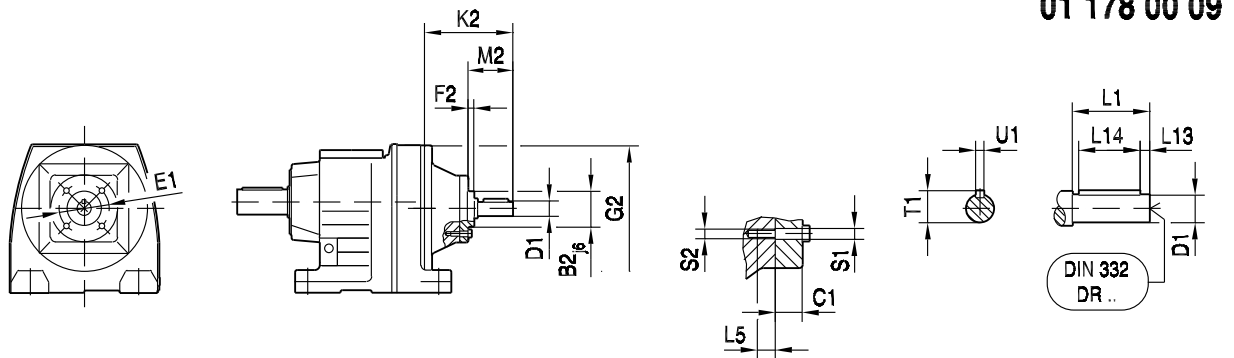

67786axx

K2	Input shaft assembly length	G2	Flange diameter on input side of gear unit
B2	Center bore diameter	F2	Center bore height
M2	Contact surface position	E1	Hole circle diameter
S1	Through bore	S2	Thread diameter
C1	Flange thickness	L5	Thread depth
D1	Shaft diameter	L1	Length of shaft end
L13	Position of key	L14	Key length
U1	Key width	T1	Key height in shaft

AD../P

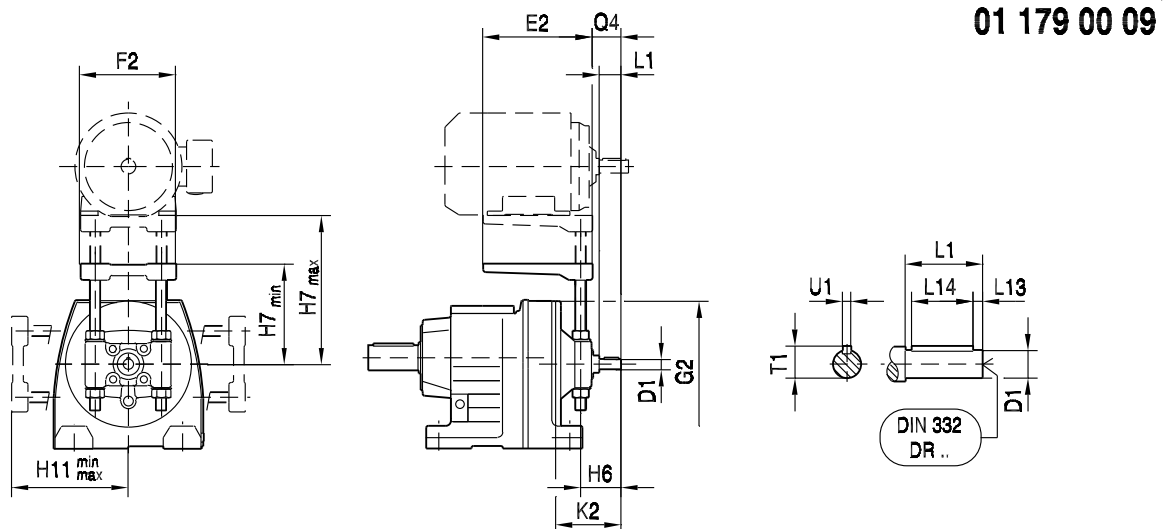

67784axx

K2	Input shaft assembly length	G2	Flange diameter on input side of gear unit
E2	Length of motor mounting platform	Q4	Distance of shaft end and base plate
F2	Width of motor mounting platform	H6	Distance of shaft end to middle of column
H7	Adjusting height	H11	Adjusting height (0°, 180°)
D1	Shaft diameter	L1	Length of shaft end
L13	Position of key	L14	Key length
U1	Key width	T1	Key height in shaft