



Manual



DFE32B Fieldbus Interface **PROFINET IO**





1	General Information	6
1.1	How to use the manual	6
1.2	Structure of the safety notes	6
1.2.1	Meaning of the signal words	6
1.2.2	Structure of the section-related safety notes	6
1.2.3	Structure of the embedded safety notes	6
1.3	Right to claim under warranty	7
1.4	Exclusion of liability	7
1.5	Copyright.....	7
2	Safety Notes	8
2.1	Other applicable documentation	8
2.2	General safety notes for bus systems.....	8
2.3	Safety functions	8
2.4	Hoist applications.....	8
2.5	Product names and trademarks	8
2.6	Disposal	9
3	Introduction	10
3.1	Content of this manual	10
3.2	Additional documentation.....	10
3.3	Characteristics	10
3.3.1	MOVIDRIVE [®] B, MOVITRAC [®] B and PROFINET	10
3.3.2	Access to all information	11
3.3.3	Monitoring functions	11
3.3.4	Diagnostics	11
3.3.5	Fieldbus monitor	11
4	Assembly and Installation Notes	12
4.1	Installing the DFE32B option card in MOVIDRIVE [®] MDX61B	12
4.1.1	Before you start	13
4.1.2	Basic procedure for installing and removing an option card (MDX61B, BG 1 - 6)	14
4.2	Installing the DFE32B option card in MOVIDRIVE [®] B	15
4.2.1	Connecting a system bus (SBus 1) between a MOVITRAC [®] B and the DFE32B option	15
4.2.2	Connecting a system bus (SBus 1) between several MOVITRAC [®] B	16
4.3	Installing the DFE32B/UOH11B gateway.....	18
4.4	Connection and terminal description DFE32B option	19
4.5	Pin assignment	20
4.6	Shielding and routing bus cables	21
4.7	TCP/IP addressing and subnetworks.....	22
4.8	Setting the IP address parameters via DCP	24
4.9	Procedure after a replacement.....	25
4.9.1	MOVIDRIVE [®] B unit replacement	25
4.9.2	MOVITRAC [®] B/gateway unit replacement	25
4.10	Operating display DFE32B option.....	26
4.10.1	PROFINET LEDs	26
4.10.2	Gateway LED	27



5	Project Planning with PROFINET	28
5.1	Project planning for the PROFINET IO controller	28
5.1.1	Assigning the PROFINET device name	29
5.1.2	Project planning for the PROFINET interface for MOVIDRIVE® B	31
5.1.3	Project planning for MOVITRAC® B or gateway with DFE32B option	36
5.1.4	Project planning for the PROFINET interface for MOVITRAC® B	37
5.2	Auto setup for gateway operation	43
5.3	Setting the MOVIDRIVE® MDX61B	45
5.4	Setting the MOVITRAC® B	46
5.5	Startup procedure for MDX61B with DFE32B option	47
5.5.1	Preliminary work	47
5.5.2	Starting up MOVIDRIVE® B with DC 24 V or AC 400 V	47
5.6	Startup procedure for the DFE32B option as gateway	49
5.6.1	Preliminary work	49
5.6.2	Starting up units with DC 24 V or AC 400 V	50
6	Operating Behavior in Conjunction with PROFINET	52
6.1	Introduction	52
6.2	The integrated Ethernet switch	54
6.3	Process data configuration	55
6.4	MOVIDRIVE® MDX61B – control	56
6.4.1	SIMATIC S7 with MOVIDRIVE® MDX61B – control example	57
6.4.2	PROFINET timeout (MOVIDRIVE® MDX61B)	57
6.4.3	Fieldbus timeout response (MOVIDRIVE® MDX61B)	57
6.5	MOVITRAC® B (gateway) – control	58
6.5.1	Control example for SIMATIC S7 with MOVITRAC® B (gateway)	59
6.5.2	SBus timeout	59
6.5.3	Unit errors	59
6.5.4	Fieldbus timeout response of the DFE32B in gateway operation	59
6.6	SIMATIC S7 Sample program	60
6.7	PROFINET alarms using the example of MOVIDRIVE® B	61
6.8	PROFINET configuration with topology detection	63
6.8.1	Introduction	63
6.8.2	Creating a PROFINET project and starting the topology editor	64
6.8.3	Specifying the topology and detecting faulty connections	65
6.8.4	Changing the port properties	67
6.8.5	Topology diagnostics	68
6.8.6	Port statistics	69
7	Parameterization via PROFIdrive Data Set 47	71
7.1	Introducing PROFINET data sets	71
7.1.1	Features of the SEW-EURODRIVE PROFINET devices	72
7.2	Structure of the PROFINET parameter channel	73
7.2.1	Parameterization via PROFIdrive data set 47 – procedure	74
7.2.2	Controller processing sequence	75
7.2.3	Addressing connected inverters	76
7.2.4	MOVILINK® parameter requests	77
7.2.5	PROFIdrive parameter requests	82
7.3	Read/write parameters via data set 47	87
7.3.1	Sample program for SIMATIC S7	87
7.3.2	Technical data PROFINET for MOVIDRIVE® DFE32B	87
7.3.3	Error codes of the PROFINET services	88



8	Integrated Web Server	89
8.1	Software requirements	89
8.2	Security settings	89
8.3	Homepage layout MOVIDRIVE [®] MDX61B with DFE32B option	90
8.4	Structure of the diagnostics applet	91
8.5	Access protection	95
9	MOVITOOLS[®] MotionStudio – Operation	96
9.1	About MOVITOOLS [®] MotionStudio	96
9.1.1	Tasks	96
9.1.2	Establishing communication with other units	96
9.1.3	Executing functions with the units	96
9.2	First steps	97
9.3	Starting the software and creating the project	97
9.4	Establishing communication and scanning the network	97
9.5	Configuring units	98
9.6	Connection mode	99
9.6.1	Overview	99
9.6.2	Setting the connection mode (online or offline)	100
9.7	Serial (RS-485) communication via interface adapter	101
9.7.1	Engineering via interface adapters (serial)	101
9.7.2	Taking the USB11A interface adapter into operation	101
9.7.3	Configuring the serial communication	104
9.7.4	Communication parameters, serial (RS-485)	106
9.8	Communication SBus (CAN) via interface adapter	107
9.8.1	Engineering via interface adapter (SBus)	107
9.8.2	Starting up the USB-CAN interface	107
9.8.3	Configuring the communication via SBus	109
9.8.4	Communication parameters for SBus	112
9.9	Communication via Ethernet	113
9.9.1	Address Editor	113
9.9.2	Configuring the communication channel via Ethernet	117
9.9.3	Setting communication parameters for SMLP	118
9.9.4	Communication parameters for SMLP	119
9.9.5	Communication ports used	119
9.10	Executing functions with the units	120
9.10.1	Unit parameterization	120
9.10.2	Reading or changing unit parameters	120
9.10.3	Starting up units (online)	121
10	Error Diagnostics	122
10.1	Diagnostics procedures	122
10.2	Error list in gateway operation	125
11	Technical Data	126
11.1	DFE32B for MOVIDRIVE [®] B, MOVITRAC [®] B and UOH11B	126
11.2	DFE32B in UOH11B gateway housing – dimension drawing	127
12	Index	128



1 General Information

1.1 How to use the manual

The manual is part of the product and contains important information on operation and service. The manual is written for all employees who assemble, install, startup, and service the product.

The manual must be accessible and legible. Make sure that persons responsible for the system and its operation, as well as persons who work independently on the unit, have read through the manual carefully and understood it. If you are unclear about any of the information in this documentation, or if you require further information, contact SEW-EURODRIVE.

1.2 Structure of the safety notes

1.2.1 Meaning of the signal words

The following table shows the grading and meaning of the signal words for safety notes, notes on potential risks of damage to property, and other notes.

Signal word	Meaning	Consequences if disregarded
▲ DANGER	Imminent danger	Severe or fatal injuries
▲ WARNING	Possible dangerous situation	Severe or fatal injuries
▲ CAUTION	Possible dangerous situation	Minor injuries
NOTICE	Possible damage to property	Damage to the drive system or its environment
INFORMATION	Useful information or tip: Simplifies the handling of the drive system.	

1.2.2 Structure of the section-related safety notes

Section safety notes do not apply to a specific action, but to several actions pertaining to one subject. The used symbols indicate either a general or a specific hazard.

This is the formal structure of a section safety note:



▲ SIGNAL WORD

Type and source of danger.

Possible consequence(s) if disregarded.

- Measure(s) to prevent the danger.

1.2.3 Structure of the embedded safety notes

Embedded safety notes are directly integrated in the instructions just before the description of the dangerous action.

This is the formal structure of an embedded safety note:

- **▲ SIGNAL WORD** Nature and source of hazard.
Possible consequence(s) if disregarded.
– Measure(s) to prevent the danger.

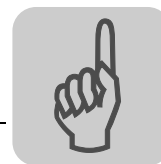

1.3 Right to claim under warranty

A requirement of fault-free operation and fulfillment of any rights to claim under limited warranty is that you adhere to the information in the manual. Therefore, read the manual before you start operating the device.

1.4 Exclusion of liability

You must comply with the information contained in the MOVIDRIVE®/MOVITRAC® documentation to ensure safe operation and to achieve the specified product characteristics and performance requirements. SEW-EURODRIVE assumes no liability for injury to persons or damage to equipment or property resulting from non-observance of these operating instructions. In such cases, any liability for defects is excluded.

1.5 Copyright

© 2010 - SEW-EURODRIVE. All rights reserved.

Copyright law prohibits the unauthorized duplication, modification, distribution, and use of this document, in whole or in part.



2 Safety Notes

2.1 Other applicable documentation

- Installation and startup only by trained personnel observing the relevant accident prevention regulations and the following documents:
 - "MOVIDRIVE® MDX60B/61B" operating instructions
 - "MOVITRAC® B" operating instructions
- Read through this manual carefully before you commence installation and startup of the DFE32B option.
- You must adhere to the information in the documentation as a prerequisite to fault-free operation and fulfillment of warranty claims.

2.2 General safety notes for bus systems

This communication system allows you to match the MOVIDRIVE® inverter to the specifics of your application. As with all bus systems, there is a danger of invisible, external (as far as the inverter is concerned) modifications to the parameters which give rise to changes in the unit behavior. This may result in unexpected (not uncontrolled) system behavior.

2.3 Safety functions

MOVIDRIVE® MDX60B/61B and MOVITRAC® B inverters may not perform any safety functions without higher-level safety systems. Use higher-level safety systems to ensure protection of equipment and personnel.

For safety applications, refer to the information in the following publications.

- Safe disconnection for MOVIDRIVE®/MOVITRAC® B

Use only those components in safety applications that were explicitly designed and delivered for this purpose by SEW-EURODRIVE.

2.4 Hoist applications

MOVIDRIVE® MDX60B/61B and the MOVITRAC® B are not designed for use as a safety device in hoist applications..

Use monitoring systems or mechanical protection devices as safety equipment to avoid possible damage to property or injury to people.

2.5 Product names and trademarks

The brands and product names contained within this manual are trademarks or registered trademarks of the titleholders.



2.6 Disposal



Observe the applicable national regulations.

Dispose of the following materials separately in accordance with the country-specific regulations in force, as:

- Electronics scrap
 - Plastic
 - Sheet metal
 - Copper
- etc.



3 Introduction

3.1 Content of this manual

This user manual illustrates:

- The Installation of the DFE32B PROFINET IO option card in the MOVIDRIVE[®] MDX61B inverter.
- The use of the DFE32B PROFINET IO option card in the MOVITRAC[®] B inverter and in the UOH11B gateway housing
- The startup of MOVIDRIVE[®] B in the PROFINET fieldbus system.
- The start up of MOVITRAC[®] B connected to the PROFINET gateway.
- The configuration of PROFINET via GSD files
- The operation of MOVITOOLS[®] MotionStudio via PROFINET.
- Diagnostics via integrated web server

3.2 Additional documentation

For information on how to connect MOVIDRIVE[®]/MOVITRAC[®] B easily and effectively to the PROFINET IO fieldbus system, you should request the following additional publications about fieldbus technology:

- MOVIDRIVE[®] fieldbus unit profile manual
- MOVITRAC[®] B/MOVIDRIVE[®] B system manual

Apart from describing the fieldbus parameters and the corresponding coding, the MOVIDRIVE[®] fieldbus unit profile manual and the MOVITRAC[®] B system manual provide examples to illustrate various control concepts and possible applications.

The MOVIDRIVE[®] fieldbus unit profile manual provides a list of all the drive inverter parameters that can be read and written via the different communication interfaces such as system bus, RS485 and via the field bus interface.

3.3 Characteristics

With the DFE32B PROFINET IO option and their powerful universal fieldbus interface, the MOVIDRIVE[®] MDX61B drive inverter and the MOVITRAC[®] B frequency inverter allow for a connection to higher-level automation systems via PROFINET IO.

3.3.1 MOVIDRIVE[®] B, MOVITRAC[®] B and PROFINET

The behavior of the inverter which forms the basis of PROFINET operation, the so-called unit profile, is independent of any particular fieldbus and is therefore a uniform feature. This allows the user to develop fieldbus-independent drive applications. This makes it much easier to change to other bus systems, such as DeviceNet (option DFD).



3.3.2 Access to all information

MOVIDRIVE[®] MDX61B and MOVITRAC[®] B offer digital access to all drive parameters and functions via the PROFINET interface. The drive inverter is controlled via fast, cyclic process data. You can use this process data channel to enter setpoints such as the setpoint speed, ramp generator time for acceleration/deceleration, etc. as well as trigger various drive functions such as enable, control inhibit, normal stop, rapid stop, etc. At the same time you can also use this channel to read back actual values from the drive inverter, such as actual speed, current, unit status, error number or reference signals.

3.3.3 Monitoring functions

Using a fieldbus system requires additional monitoring functions for the drive technology, for example, time monitoring of the fieldbus (fieldbus timeout) or rapid stop concepts. You can, for example, adapt the monitoring functions of MOVIDRIVE[®]/MOVITRAC[®] specifically to your application. You can determine, for instance, which of the drive inverter's error responses should be triggered in the event of a bus error. A rapid stop makes sense for many applications, although this can also be achieved by "freezing" the last setpoints so the drive continues operating with the most recently valid setpoints (such as with a conveyor belt). As the range of functions for the control terminals is also guaranteed in fieldbus mode, you can continue to implement rapid stop concepts using the terminals of the drive inverter, irrespective of the fieldbus used.

3.3.4 Diagnostics

The MOVIDRIVE[®] drive inverter and the MOVITRAC[®] B frequency inverter offer you numerous diagnostics options for startup and service. For example, you can use the integrated fieldbus monitor to control setpoint values sent from the higher-level controller as well as the actual values. The integrated Web server allows you to access the diagnostic values using a standard browser.

3.3.5 Fieldbus monitor

Furthermore, you are supplied with a variety of additional information about the status of the fieldbus interface. The fieldbus monitor function in conjunction with the MOVITOOLS[®] MotionStudio PC software offers you an easy-to-use diagnostic tool for setting all drive parameters (including the fieldbus parameters) and for displaying the fieldbus and device status information in detail.



4 Assembly and Installation Notes

This section contains information about assembly and installation of the DFE32B PROFINET IO option card in the MOVIDRIVE® MDX61B, MOVITRAC® B and UOH11B gateway housing.

4.1 Installing the DFE32B option card in MOVIDRIVE® MDX61B

INFORMATION



- Only SEW-EURODRIVE engineers are allowed to install or remove option cards for MOVIDRIVE® MDX61B size 0.
- Users may only install or remove option cards for MOVIDRIVE® MDX61B sizes 1 to 6.
- Plug the DFE33B PROFINET IO option card into the fieldbus slot [1].
- Only use connectors and cables approved for PROFINET IO when cabling.

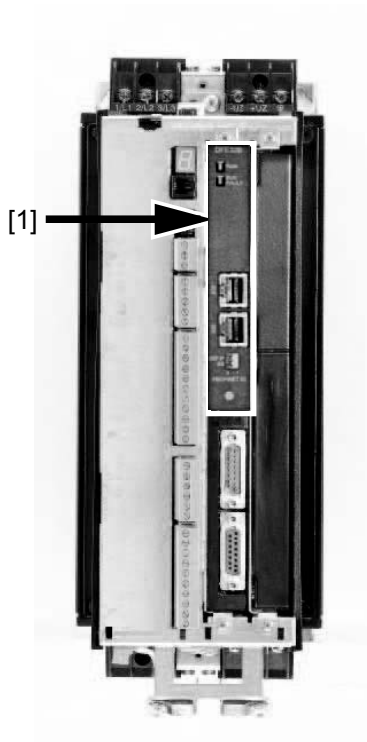

62179AXX



4.1.1 Before you start

Observe the following notes before installing or removing an option card:

- Disconnect the inverter from the power. Switch off the DC 24 V and the line voltage.
- Take appropriate measures (discharge strap, conductive shoes, etc.) to protect the option card from electrostatic charge before touching it.
- **Before installing** the option card, remove the keypad and the front cover (see MOVIDRIVE® MDX60B/61B operating instructions, section "Installation").
- **After having installed** the option card, replace the keypad and the front cover (see MOVIDRIVE® MDX60B/61B operating instructions, section "Installation").
- Keep the option card in its original packaging until immediately before you are ready to install it.
- Hold the option card by its edges only. Do not touch any of the components.



4.1.2 Basic procedure for installing and removing an option card (MDX61B, BG 1 - 6)

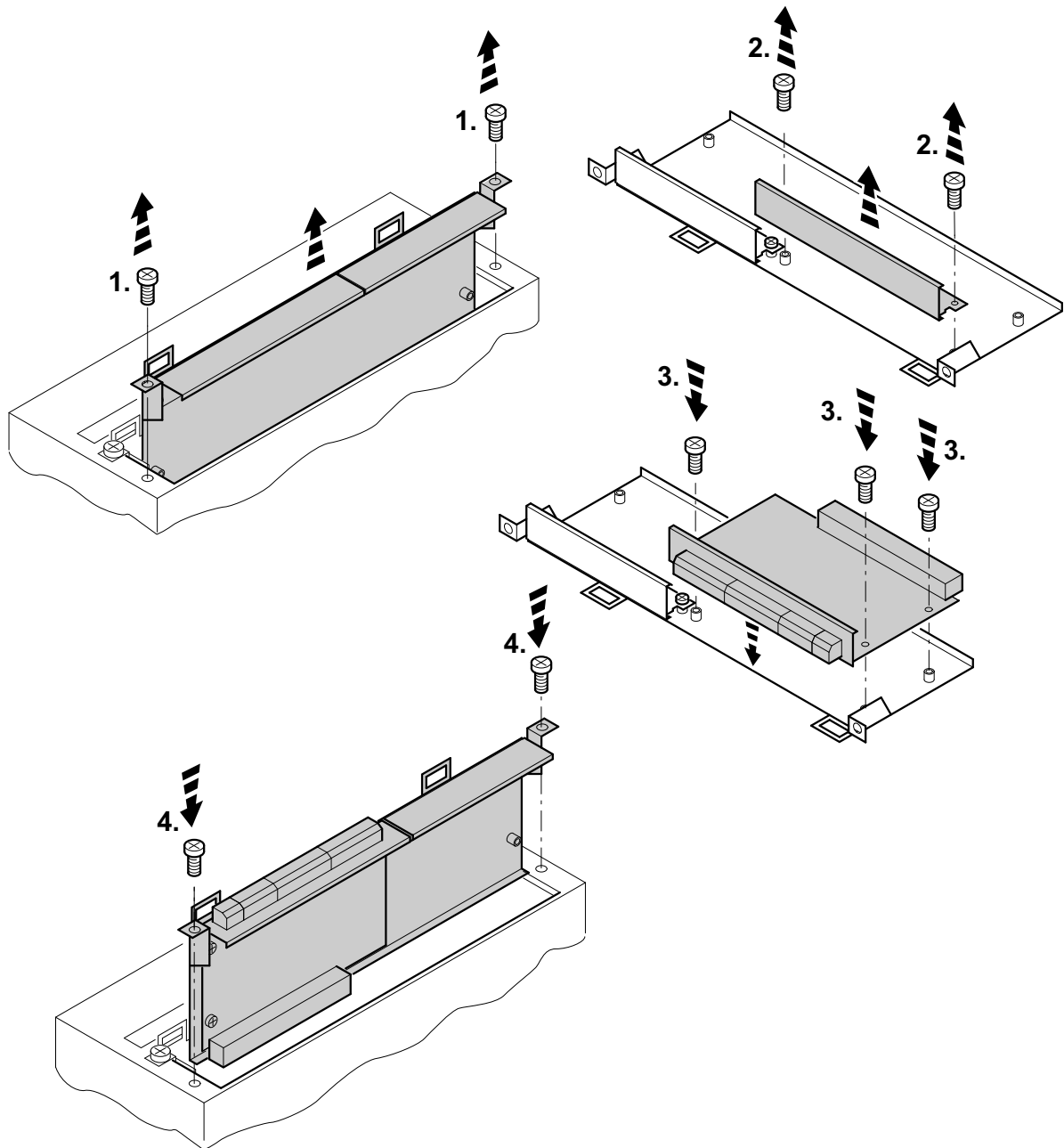

60039AXX

1. Remove the two retaining screws holding the card retaining bracket. Pull the card retaining bracket out evenly from the slot (do not twist!).
2. Remove the 2 retaining screws from the black cover plate on the card retaining bracket. Remove the black cover plate.
3. Position the option card onto the retaining bracket so that the three retaining screws fit into the corresponding bores on the card retaining bracket.
4. Insert the retaining bracket with the installed option card into the slot, pressing slightly so it is seated properly. Secure the card retaining bracket with the two retaining screws.
5. To remove the option card, follow the instructions in reverse order.



4.2 Installing the DFE32B option card in MOVIDRIVE® B

INFORMATION



- MOVITRAC® B does not require a special firmware status.
- Only SEW-EURODRIVE personnel may install or remove options cards for MOVITRAC® B.

4.2.1 Connecting a system bus (SBus 1) between a MOVITRAC® B and the DFE32B option

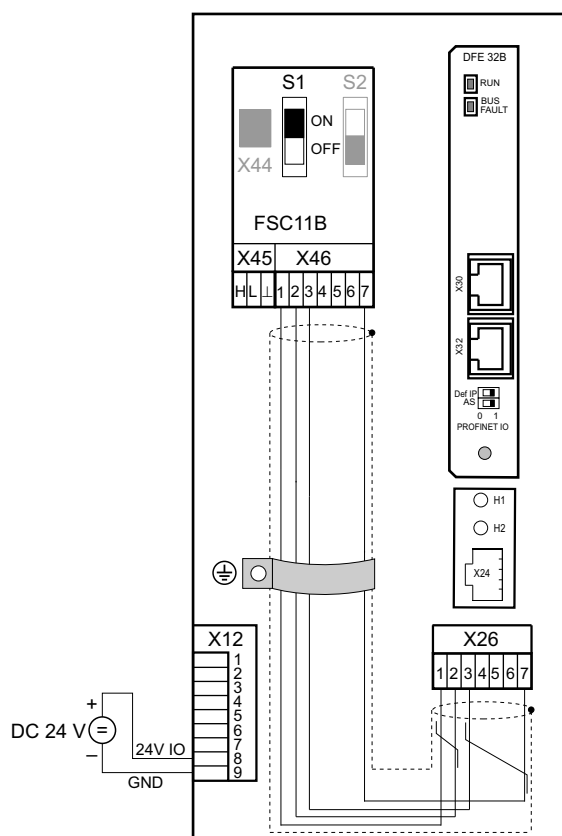

61633AXX

X46	X26	Terminal assignment
X46:1	X26:1	SC11 SBus +, CAN high
X46:2	X26:2	SC12 SBus -, CAN low
X46:3	X26:3	GND, CAN GND
X46:7	X26:7	DC 24 V

X12	Terminal assignment
X12:8	DC+24 V input
X12:9	GND reference potential for binary inputs

To simplify cabling, the DFE32B option can be supplied with DC 24 V from X46.7 of the MOVITRAC® B to X26.7.

MOVITRAC® B must be supplied with DC 24 V at terminals X12.8 and X12.9 when it supplies the DFE32B option.

Activate the system bus terminating resistor at the FSC11B option (S1 = ON).



4.2.2 Connecting a system bus (SBus 1) between several MOVITRAC® B

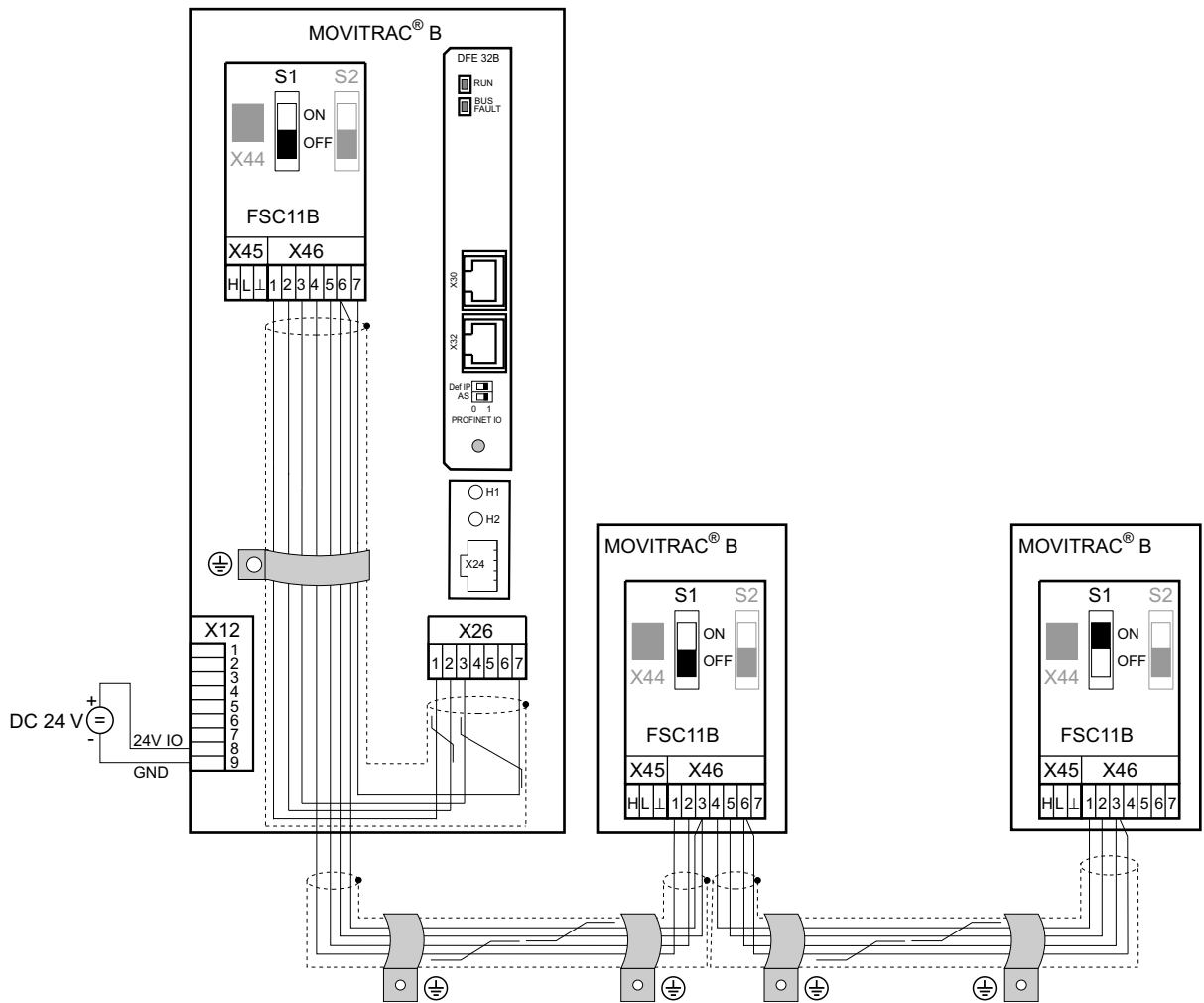

61635AXX

MOVITRAC® B		DFE32B via UOH11B gateway housing	
X46	Terminal assignment	X26	Terminal assignment
X46:1	SC11 (System bus high, incoming)	X26:1	SC11 SBus +, CAN High
X46:2	SC12 (System bus low, incoming)	X26:2	SC12 SBus -, CAN Low
X46:3	GND (System bus reference)	X26:3	GND, CAN GND
X46:4	SC21 (System bus high, outgoing)		
X46:5	SC22 (System bus low, outgoing)		
X46:6	GND (System bus reference)		
X46:7	DC 24 V	X26:7	DC 24 V

X12	Terminal assignment
X12:8	DC+24 V input
X12:9	GND reference potential for binary inputs



Please note:

- Use a 2x2 core twisted pair and shielded copper cable (data transmission cable with braided copper shield). Connect the shield flatly on both sides of the electronics shield clamp of MOVITRAC® B. Also connect the ends of the shield to GND. The cable must meet the following specifications:
 - Cable cross section 0.25 mm² (AWG18) ... 0,75 mm² (AWG23)
 - Line resistance 120 Ω at 1 MHz
 - Capacitance per unit length = 40 pF/m at 1 kHzSuitable cables are CAN bus or DeviceNet cables.
- The permitted total cable length depends on the baud rate setting of the SBus:
 - 250 kBaud: 160 m
 - 500 kBaud: 80 m
 - 1000 kBaud: 40 m
- Connect the system bus terminating resistor (S1 = ON) at the end of the system bus connection. Switch off the terminating resistor on the other units (S1 = OFF). The DFE32B gateway must always be connected either at the beginning or the end of the system bus connection and feature a permanently installed terminating resistor.

INFORMATION



- There must not be any potential displacement between the units connected with the SBus. Take suitable measures to avoid potential displacement, such as connecting the unit ground connectors using a separate cable.
- Point-to-point wiring is not permitted.



Assembly and Installation Notes

Installing the DFE32B/UOH11B gateway

4.3 Installing the DFE32B/UOH11B gateway

The following figure shows the connection of the DFE32B option via the UOH11B:X26 gateway housing.

INFORMATION



- Only SEW-EURODRIVE engineers are allowed to install or remove option cards in/from the UOH11B gateway housing.

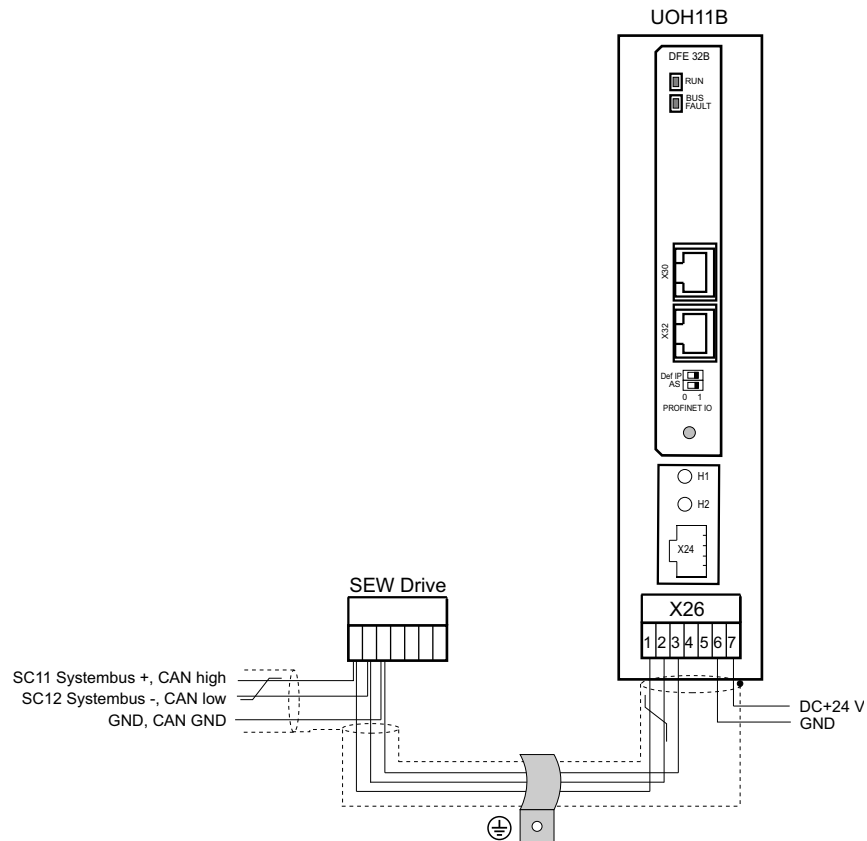

61636AXX

UOH11B gateway housing	
X26	Terminal assignment
X26:1	SC11 system bus +, CAN high
X26:2	SC12 system bus -, CAN low
X26:3	GND, CAN GND
X26:4	Reserved
X26:5	Reserved
X26:6	GND, CAN GND
X26:7	DC 24 V

The gateway housing is powered with DC 24 V at X26.

Connect the system bus terminating resistor at the end of the system bus connection.



4.4 Connection and terminal description DFE32B option

Part number DFE32B PROFINET IO fieldbus interface option: 1821 345 6

INFORMATION



- The DFE32B PROFINET IO fieldbus interface is only possible in conjunction with MOVIDRIVE® MDX61B, not with MDX60B.
- Plug the DFE32B option into the fieldbus slot.

Front view of DFE32B	Description	DIP switch	Function
<p>DFE 32B</p> <p>RUN</p> <p>BUS FAULT</p> <p>X30</p> <p>X32</p> <p>Def IP AS</p> <p>0 1</p> <p>PROFINET IO</p> <p>61630AXX</p>	<p>LED RUN (red/yellow/green)</p> <p>LED BUS FAULT (red/yellow/green)</p>		<p>Shows the current status of the DFE32B.</p> <p>Shows the status of the PROFINET IO connection.</p>
	<p>X30: Ethernet connection</p> <p>LED Link (green)</p> <p>LED Activity (yellow)</p>		
	<p>X32: Ethernet connection</p> <p>LED Link (green)</p> <p>LED Activity (yellow)</p>		
	<p>DIP switch</p>	<p>AS</p> <p>DEF IP</p>	<p>Auto-setup for gateway operation</p> <p>Resets the address parameters to the following default values:</p> <ul style="list-style-type: none"> • IP address: 192.168.10.4 • Subnet mask: 255.255.255.0 • Gateway: 1.0.0.0 • PROFINET device name: PNETDeviceName_MACID

Front view of MOVITRAC® B, DFE32B and UOH11B	Description	Function
<p>H1</p> <p>H2</p> <p>X24</p> <p>58129axx</p>	<p>LED H1 (red)</p>	<p>System error (only for gateway functionality)</p>
	<p>LED H2 (green)</p>	<p>Reserved</p>
	<p>X24 X terminal</p>	<p>RS485 interface for diagnostics via PC and MOVITOOLS® MotionStudio (only for MOVITRAC® B)</p>



4.5 Pin assignment

Use prefabricated, shielded RJ45 plug connectors compliant with IEC 11801 edition 2.0, category 5.

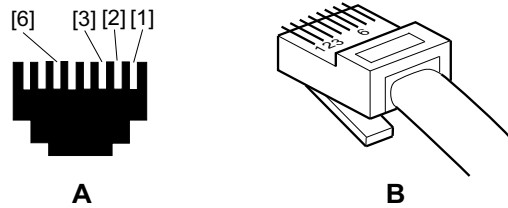

Figure 1: Pin assignment of an RJ45 plug connector

54174AXX

A = Front view

B = View from back

[1] Pin 1 TX+ Transmit Plus

[2] Pin 2 TX- Transmit Minus

[3] Pin 3 RX+ Receive Plus

[6] Pin 6 RX- Receive Minus

MOVIDRIVE® B/MOVITRAC® B connection

To connect the DFE32B, connect the Ethernet interface X30 or X32 (RJ45 connector) using a category 5, class D shielded twisted-pair cable in compliance with IEC 11801 edition 2.0. The integrated switch provides support for realizing a line topology.

INFORMATION



- According to IEC 802.3, the maximum cable length for 10/100 Mbaud Ethernet (10 BaseT / 100 BaseT), e.g. between DFE32B and switch, is 100 m.
- VLAN tag prioritized Ethernet frames with the frame identification 8892_{hex} are used for the real-time data exchange with PROFINET IO. This requires switched networks. The switches must support prioritization. Hubs are not permitted. Data transmission takes place using the full duplex process with 100 MBit. Detailed information on cabling can be found in the "PROFINET installation guideline" publication that was issued by the PROFINET user organization.



4.6 Shielding and routing bus cables

Only use shielded cables and connection elements that also meet the requirements of category 5, class 2 in compliance with IEC 11801 edition 2.0.

Correct shielding of the bus cable attenuates electrical interference that can occur in industrial environments. The following measures ensure the best possible shielding:

- Manually tighten the mounting screws on the connectors, modules, and equipotential bonding conductors.
- Use only connectors with a metal housing or a metallized housing.
- Connect the shielding in the connector over a wide surface area.
- Apply the shielding of the bus cable on both ends.
- Route signal and bus cables in separate cable ducts. Do not route them parallel to power cables (motor leads).
- Use metallic, grounded cable racks in industrial environments.
- Route the signal cable and the corresponding equipotential bonding close to each other using the shortest possible route.
- Avoid using plug connectors to extend bus cables.
- Route the bus cables closely along existing grounding surfaces.

NOTICE



In case of fluctuations in the ground potential, a compensating current may flow via the bilaterally connected shield that is also connected to the protective earth (PE). Make sure you supply adequate equipotential bonding according in accordance with relevant VDE regulations in such a case.



4.7 TCP/IP addressing and subnetworks

Introduction

The settings for the address of the IP protocol are made using the following parameters:

- IP address
- Subnet mask
- Standard gateway

The addressing mechanisms and subdivision of the IP networks into subnets are explained in this chapter to help you set the parameters correctly.

IP address

The IP address is a 32-bit value that uniquely identifies a node in the network. An IP address is represented by four decimal numbers separated by decimal points.

Example: 192.168.10.4

Each decimal number stands for one byte (= 8 bits) of the address and can also be represented using binary code (→ following table).

Byte 1		Byte 2		Byte 3		Byte 4
11000000	.	10101000	.	00001010	.	00000100

The IP address comprises a network address and a node address (→ following table).

Network address	Node address
192.168.10	4

The part of the IP address that denotes the network and the part that identifies the node is determined by the network class and the subnet mask.

Node addresses cannot consist of only zeros or ones (binary) because they represent the network itself or a broadcast address.

Network classes

The first byte of the IP address determines the network class and as such represents the division into network addresses and node addresses.

Value range Byte 1	Network class	Complete network address (Example)	Meaning
0 ... 127	A	10.1.22.3	10 = Network address 1.22.3 = node address
128 ... 191	B	172.16.52.4	172.16 = Network address 52.4 = node address
192 ... 223	C	192.168.10.4	192.168.10 = Network address 4 = node address

This rough division is not sufficient for a number of networks. They also use an explicit, adjustable subnet mask.

Subnet mask

A subnet mask is used to divide the network classes into even finer sections. Like the IP address, the subnetwork mask is represented by four decimal numbers separated by decimal points. Every decimal number stands for one byte.

Example: 255.255.255.128

Each decimal number stands for one byte (= 8 bits) of the subnetwork mask and can also be represented using binary code (→ following table).

Byte 1		Byte 2		Byte 3		Byte 4
11111111	.	11111111	.	11111111	.	10000000

If you compare the IP addresses with the subnet masks, you see that in the binary representation of the subnet mask all ones determine the network address and all the zeros



determine the node address (→ following table).

		Byte 1	.	Byte 2	.	Byte 3	.	Byte 4
IP address	decimal	192	.	168.	.	10	.	128
	binary	11000000	.	10101000	.	00001010	.	10000000
Subnet mask	decimal	255	.	255	.	255	.	128
	binary	11111111	.	11111111	.	11111111	.	10000000

The class C network with the address 192.168.10. is further subdivided into 255.255.255.128 using the subnet mask. Two networks are created with the address 192.168.10.0 and 192.168.10.128.

The following node addresses are permitted in the two networks:

- 192.168.10.1 ... 192.168.10.126
- 192.168.10.129 ... 192.168.10.254

The network nodes use a logical AND operation for the IP address and the subnet mask to determine whether there is a communication partner in the same network or in a different network. If the communication partner is in a different network, the standard gateway is addressed.

Standard gateway

The standard gateway is also addressed via a 32-bit address. The 32-bit address is represented by four decimal numbers separated by decimal points.

Example: 192.168.10.1

The standard gateway establishes a connection to other networks. In this way, a network node that wants to address another node can use a logical AND operation with the IP address and the subnetwork mask to decide whether the desired node is located in the same network. If this is not the case, the node addresses the standard gateway (router), which must be part of the actual network. The standard gateway then takes on the job of transmitting the data packages.



4.8 Setting the IP address parameters via DCP

Initial startup

For PROFINET IO, the IP address parameters are determined via the "DCP" protocol (Discovery and Configuration Protocol). DCP operates with device names. The device name uniquely identifies a PROFINET IO node in the network. It is identified with the PROFINET IO controller for the project planning of the node and also set using the project planning software on the PROFINET IO device. With the aid of the device name, the controller identifies the device during startup and transfers the corresponding IP address parameters. Settings directly on the slave are no longer required. The basic procedure is described with SIMATIC STEP 7 as an example in section "Project Planning with PROFINET" (→ subsection "Assigning the PROFINET device name").

Resetting the IP address parameters

If you do not know the IP address parameters and cannot access the inverter using the serial interface or the DBG60B keypad, you can reset the IP address parameters to the default values using the DIP switch "Def IP".

This action resets the DFE32B option to the following default values:

- IP address: 192.168.10.4
- Subnet mask: 255.255.255.0
- Default gateway: 1.0.0.0
- PROFINET device name: PNETDeviceName_MACID

Proceed as follows to reset the IP address parameters to the default values:

- Switch off the 24 V DC supply voltage and the mains voltage.
- Set the DIP switch "Def IP" on the DFE32B option to "1".
- Switch the DC 24 V supply voltage and the line voltage back on.
- Wait until the DFE32B option boots up. This is indicated by the green "Run" LED.

You can now access the inverter via the IP address 192.168.10.4. Proceed as follows to set new IP address parameters:

- Start a web browser and access the homepage of the DFE32B option or start MOVITOOLS® MotionStudio.
- Select the required address parameters.
- Set the DIP switch "Def IP" on the DFE32B option to "0".
- The new address parameters are adopted after the device is switched off and switched on again.



4.9 Procedure after a replacement

4.9.1 MOVIDRIVE® B unit replacement

If you insert the memory card of the replaced MOVIDRIVE® B in the new MOVIDRIVE® B, the new unit is recognized by the PROFINET IO controller without any additional measures.

INFORMATION



If you do **not** install the memory card of the replaced MOVIDRIVE® B in the new MOVIDRIVE® B, you have to perform a complete startup of the inverter or you have to load the saved parameter set into the new MOVIDRIVE® B. Further, you have to set the PROFINET IO unit name again using the project planning software. Proceed as with an initial startup (→ section "Project Planning with PROFINET").

There are no measures required if only the DFE32B option is replaced.

4.9.2 MOVITRAC® B/gateway unit replacement

- Only for device replacement MOVITRAC® B with fieldbus option: You have to load the saved parameter set into the new MOVITRAC® B, or you have to perform a complete startup of the inverter (→ MOVITRAC® B operating instructions).
- You have to set the PROFINET IO unit name again using the project planning software. Proceed as with an initial startup (→ section "Project Planning with PROFINET").
- **Prior to the auto setup**, check the parameters *P884 SBus Baud Rate* and *P831 Fieldbus Timeout response*. The baud rate of the devices connected to the SBus has to correspond to the baud rate of the gateway (DFE32B). Use the parameter tree of the gateway in MOVITOOLS® MotionStudio.
- Now activate the auto setup function. Set the "AS" DIP switch on the DFE32B option to 1.



4.10 Operating display DFE32B option

4.10.1 PROFINET LEDs

There are two LEDs on the DFE32B option card that display the current status of the DFE32B option and the PROFINET system.

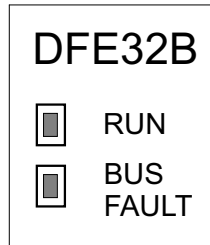

61629AXX

RUN LED

The **RUN** LED indicates that the bus electronics are operating correctly

States of the RUN LED	Cause of error	Remedy
Green	<ul style="list-style-type: none"> DFE32B hardware OK. Proper operation 	-
Off	<ul style="list-style-type: none"> DFE32B is not ready for operation 	<ul style="list-style-type: none"> Switch the unit on again. Consult SEW service if the error occurs again.
Red	<ul style="list-style-type: none"> Error in the DFE32B hardware 	
Flashing green	<ul style="list-style-type: none"> Hardware of the DFE32B does not boot up. 	<ul style="list-style-type: none"> Switch the unit on again. Set default IP address parameter using "DEF IP" DIP switch. Consult SEW service if the error occurs again.
Flashing yellow		
Yellow		<ul style="list-style-type: none"> Switch the unit on again. Consult SEW service if the error occurs again.

BUS FAULT LED

The **BUS FAULT** LED displays the status of the PROFINET.

Status of the BUS FAULT LED	Cause of error	Remedy
Off	<ul style="list-style-type: none"> PROFINET IO device is currently exchanging data with the PROFINET IO controller (Data Exchange). 	-
Flashing green Flashing green/red	<ul style="list-style-type: none"> The flash test in the project planning for the PROFINET IO controller is activated to visually locate the nodes. 	-
Red	<ul style="list-style-type: none"> Connection to the PROFINET IO controller has failed. PROFINET IO device does not detect a link. Bus interruption PROFINET IO controller is not in operation 	<ul style="list-style-type: none"> Check the PROFINET connection of the DFE32B option Check the PROFINET IO controller. Check the cabling of your PROFINET network
Yellow Flashing yellow	<ul style="list-style-type: none"> The STEP 7 hardware configuration contains a module that is not permitted. 	<ul style="list-style-type: none"> Switch the STEP 7 hardware configuration to ONLINE and analyze the component status of the slots in the PROFINET IO device.



Link/Activity LED The two LEDs **Link (green)** and **Activity (yellow)**, integrated in the RJ45 plug connectors (X30, X32), display the status of the Ethernet connection.

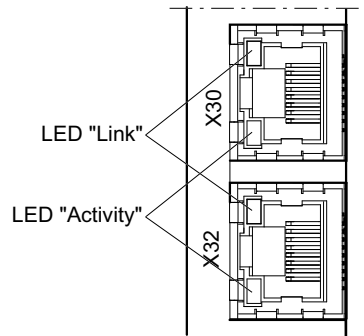

61880AXX

LED/state	Meaning
Link/green	There is an Ethernet connection.
Link/off	There is no Ethernet connection.
Activity/yellow	Data is currently being exchanged via Ethernet.

INFORMATION



- As the firmware of the DFE32B option card requires approximately 10 seconds for initialization, the status "0" (inverter not ready) is displayed in the 7-segment display of MOVIDRIVE® during this time.
- The Run LED on the DFE32B option card lights up green.

4.10.2 Gateway LED

LEDs H1 and H2 indicate the communication status in gateway operation.

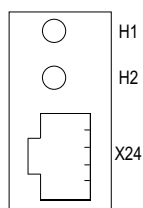

58129axx

LED H1 Sys-fault (red)		Only for gateway function
Status	Status	Description
Red	System error	Gateway is not configured or one of the drives is inactive
Off	SBus ok	Gateway is configured correctly
Flashing	Bus scan	Bus is being checked by the gateway

INFORMATION



- LED **H2** (green) is currently reserved.
- X terminal X24 is the RS485 interface for diagnostics via PC and MOVITools® MotionStudio.



5 Project Planning with PROFINET

This Chapter describes the project planning for the MOVIDRIVE® B and MOVITRAC® B/gateway inverters with the DFE32B option. The following GSD file is used for the project planning of the DFE32B with MOVIDRIVE® B or in MOVITRAC® B:

GSDML-V2.1-SEW-DFE-DFS-2Ports-jjjjmmmt.xml

This GSD file contains the unit description for the operation of the DFE32B in MOVIDRIVE® B or as fieldbus gateway for MOVITRAC® B.

5.1 Project planning for the PROFINET IO controller

This chapter describes the project planning for MOVIDRIVE® B or MOVITRAC® B with PROFINET using the current GSD(ML) file. The project planning is described using the example of the SIMATIC Manager project planning software with a SIMATIC CPU 315F 2 PN/DP.

Installing the GSD file

- Start STEP 7 HWKONFIG and select the [Install new GSD file] menu item in the [Extras] menu.
- Select the file "GSDML-V2.1-SEW-DFE-DFS-2Ports-YYYYMMDD.xml" on the "Software ROM 7" CD in the following dialog. "JJJJMMTT" [YYYYMMDD] represents the date of the file. You can navigate to the required directory via [Browse]. Confirm your selection by clicking [OK].
- The SEW PROFINET IO DFE32B connection can be found under [Additional Field Devices] / [Drives] / [SEW] / [DFE/DFS(2Ports)].

INFORMATION



The latest GSD file version is also available for download on the SEW website (www.sew-eurodrive.de) in the Software section.



5.1.1 Assigning the PROFINET device name

The general procedure is described using SIMATIC STEP 7 as an example.

- In STEP7 HWCONFIG, select [Target system] / [Ethernet] / [Edit Ethernet node].

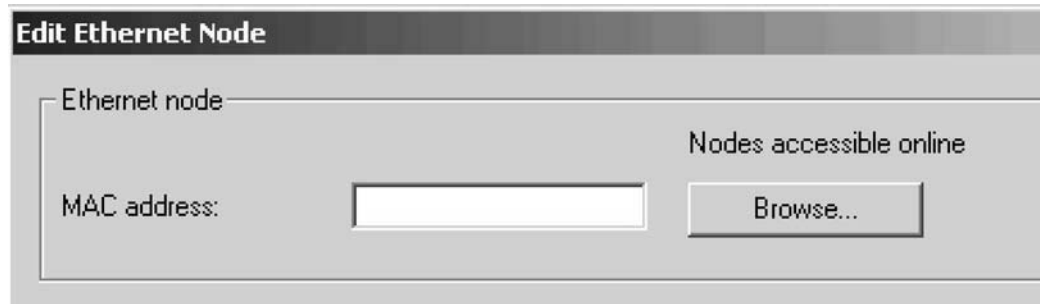

11727AEN

- Click on the "Browse" button. You receive an overview of all PROFINET IO nodes that you can reach online with your project planning tool (→ following figure).

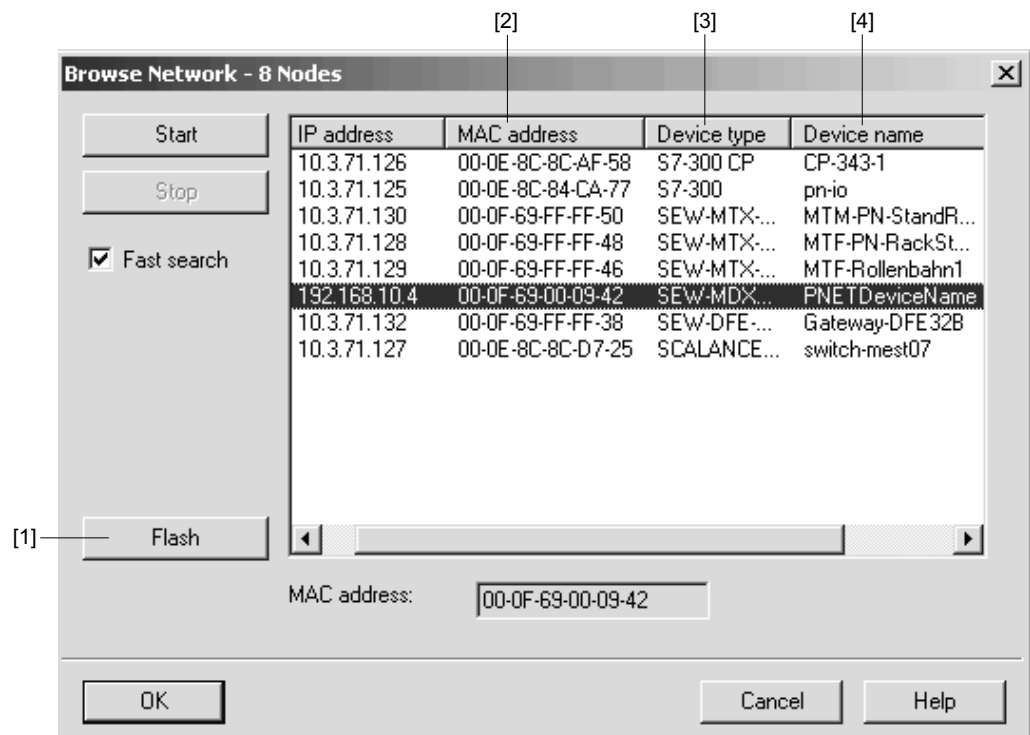

62340AEN

- Choose the required node. The SEW node is displayed under device type [3] as "SEW-MDX61B+DFE32B". The device name [4] is set to "PNETDeviceName" ex works and must be adapted to your system conditions by you. Several MDX61B units can be distinguished between by the MAC addresses [2] displayed. The MAC address [2] is attached to the DFE32B option. Use the [Flash] button [1] to have status LED of the selected DFE32B flash green to check your selection.



62330AEN

[1]	[Close] button
[2]	"Device name" edit box
[3]	[Assign IP configuration] button
[4]	"Subnet mask" edit box
[5]	"IP address" edit box
[6]	[Browse] button
[7]	"Address" input field
[8]	[Assign name] button
[9]	[Reset] button

- Enter the device name in the "Device name" edit box [2] and click the [Assign name] button [8]. The device name is now transferred to the node and saved there. It can be up to 255 characters long.



- **INFORMATION:** For the following step, the IO controller must not yet be in a cyclic data transmission with the IO devices.
Specify an IP address [5] and a subnet mask [4] as well as a router address [7] if required. Click the [Assign IP configuration] [3] button.
- Click the [Browse] [6] button again to check whether your settings have been adopted.
Click [Close] [1].
- Click [Reset] [9] to reset the device name of the DFE32B online. Now you need to restart the DFE32B.

5.1.2 Project planning for the PROFINET interface for MOVIDRIVE® B

Creating a new project

Start the SIMATIC Manager and create a new project. Select your control type and add the required modules. The OB82, OB86 and OB122 modules are particularly useful.

The OB82 module makes sure that the controller does not go to "STOP" for so-called diagnostic alarms. The OB86 module indicates the failure of the decentralized periphery. The OB122 module is called up if the controller cannot access data of a node of the decentralized periphery. This can occur, for example, when the DFE32B is ready for operation later than the control system.

- Start STEP7 HWCONFIG and select the PN-IO slot in the control rack.
- Add a PROFINET IO system by right-clicking the context menu with your mouse. Specify an IP address for the PROFINET IO controller when doing this. Add a new PROFINET subsystem using the [Ethernet] button.
- in the hardware catalog, open [PROFINET IO] / [Additional Field Devices] / [Drives] / [SEW] / [DFE/DFS(2Ports)] [1].

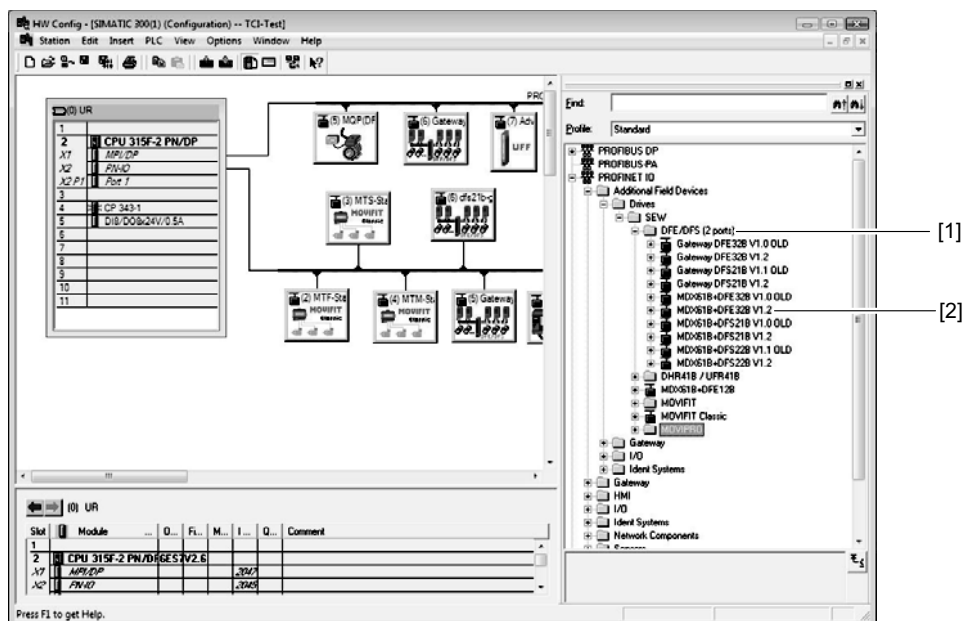

68064AEN

There are several entries.



Project Planning with PROFINET

Project planning for the PROFINET IO controller

- Copy the required entry to the PROFINET IO system via drag & drop:
 - Select "MDX61B+DFE32B V1.2" [2] if your controller supports topology detection.
 - Select "MDX61B+DFE32B V1.2 **ALT**" if your controller does **not** support topology detection.
- Assign the name of the PROFINET node.
This name must later correspond to the PROFINET unit name specified in the DFE32B.
- Delete the entry on slot 2 in to perform the project planning for your application. Select the process data configuration required for your application.
- Specify the IO and periphery addresses for the configured data widths and save your configuration.

The slot model is used for project planning with PROFINET. Each slot is assigned to a DFE32B communication interface.

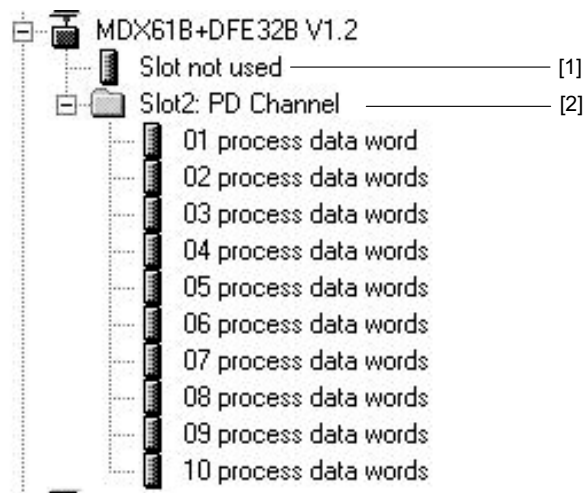

68065AEN

Slot 1: Must be assigned "Slot not used" [1]

Slot 2: Process data channel [2]. Number of process data, cyclically exchanged between PROFINET IO controller and PROFINET IO device.

- Extend your user program by data exchange with the new units.
- Process data transfer is consistent. SFC14 and SFC15 can be used to transfer process data.



Node configuration

When the individual slots are configured, the new node has to be configured with further settings. Double-click the device symbol of the new node to open the following dialog.

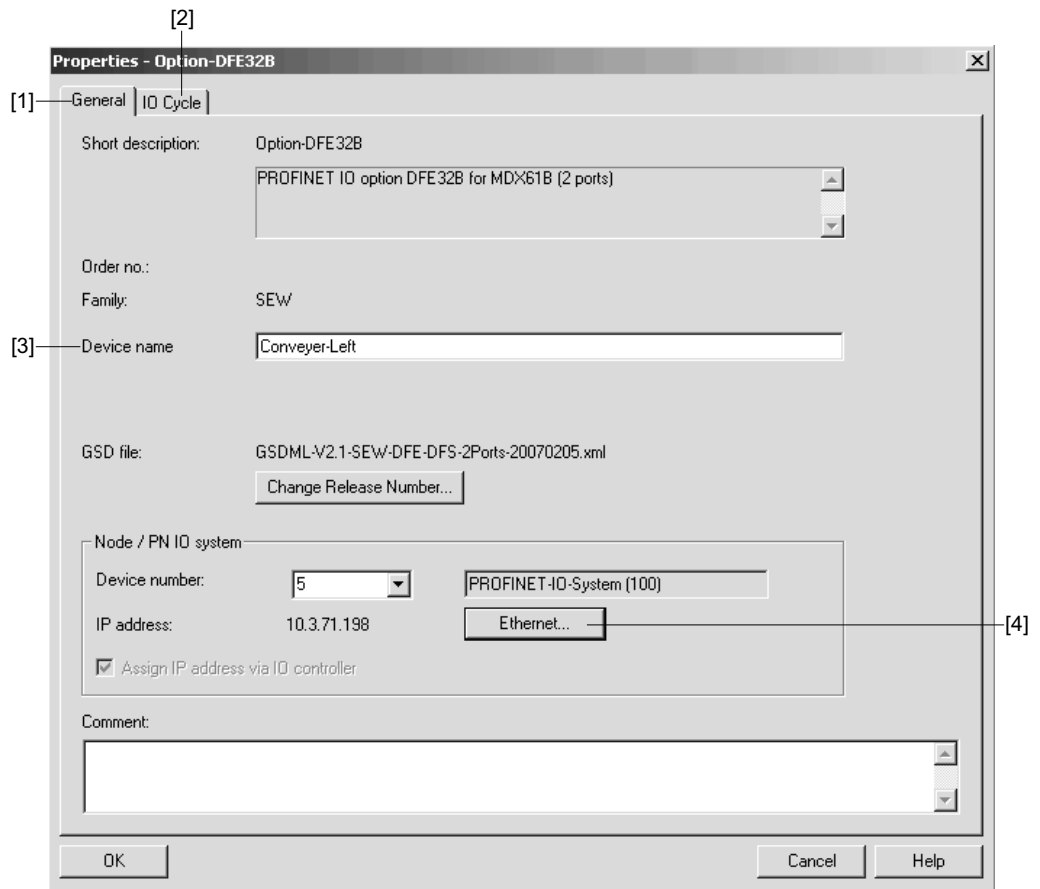

62336AEN

[1]	"General" tab
[2]	"IO cycle" tab
[3]	"Device name" edit box
[4]	[Ethernet] button

- Enter the device name mentioned above in the "Device name" edit box [3] on the "General" tab [1]. Note that the name is case-sensitive.



Project Planning with PROFINET

Project planning for the PROFINET IO controller

- Click [Ethernet] [4] in the "Node/PK-IO System" section to enter the IP address assigned before (→ following figure).

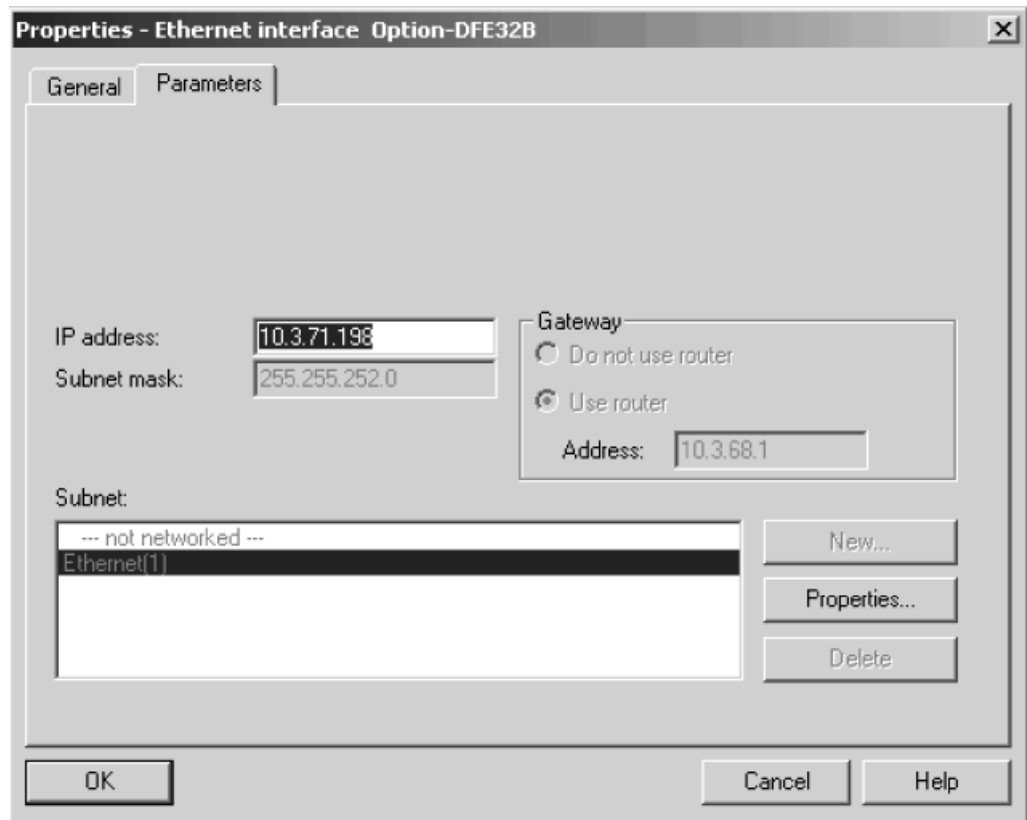

11728AEN

- On the "IO Cycle" tab [2], you can specify an update time for the node to update its process data. The DFE32B option in MOVIDRIVE® B supports a minimum update time of 2 ms (→ following figure).



11729AEN



5.1.3 Project planning for MOVITRAC® B or gateway with DFE32B option

General

The inverter must be given a specific PROFINET configuration by the IO controller to define type and number of input and output data words used for the transmission. You have the opportunity to control the drives via process data and to read and write all parameters of the fieldbus interface in an acyclic way.

The following figure describes the data exchange between the programmable controller (IO controller), the fieldbus interface (IO device) and an inverter with process data channel.

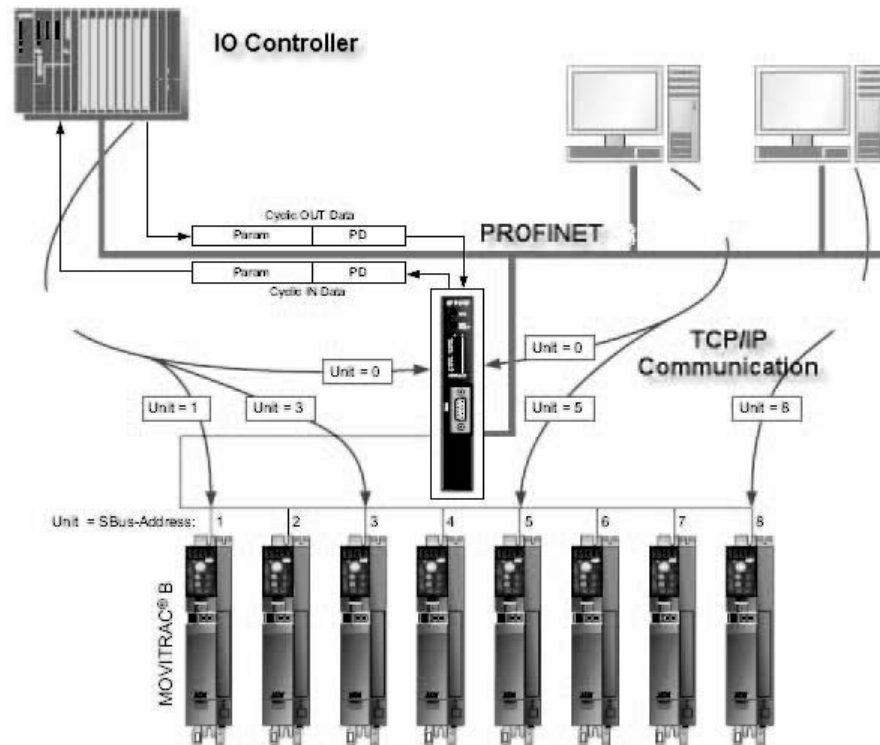

62258AXX

Configuring the process data

The PROFINET interface allows for different configurations for the data exchange between IO controller and IO device. The configurations are determined by the default process data width for SEW inverters of three process data words. The fieldbus interface then distributes these process data words to the individual devices. The PROFINET interface accepts 1×3 to 8×3 process data words.

INFORMATION



3 PDs are always assigned to any SBus node.



5.1.4 Project planning for the PROFINET interface for MOVITRAC® B

Creating a new project

Start the SIMATIC Manager and create a new project. Select your control type and add the required modules. The OB82, OB86 and OB122 modules are particularly useful.

The OB82 module makes sure that the controller does not go to "STOP" for so-called diagnostic alarms. The OB86 module indicates the failure of the decentralized periphery. The OB122 module is called up if the controller cannot access data of a node of the decentralized periphery. This can occur, for example, when the DFE32B is ready for operation later than the control system.

- Start STEP7 HWCONFIG and select the PROFINET IO slot in the control rack.
- Add a PROFINET IO system by right-clicking the context menu with your mouse. Specify an IP address for the PROFINET IO controller when doing this. Add a new PROFINET subsystem using the [Ethernet] button.
- in the hardware catalog, open [PROFINET IO] / [Additional Field Devices] / [Drives] / [SEW] / [DFE/DFS(2Ports)] [1].

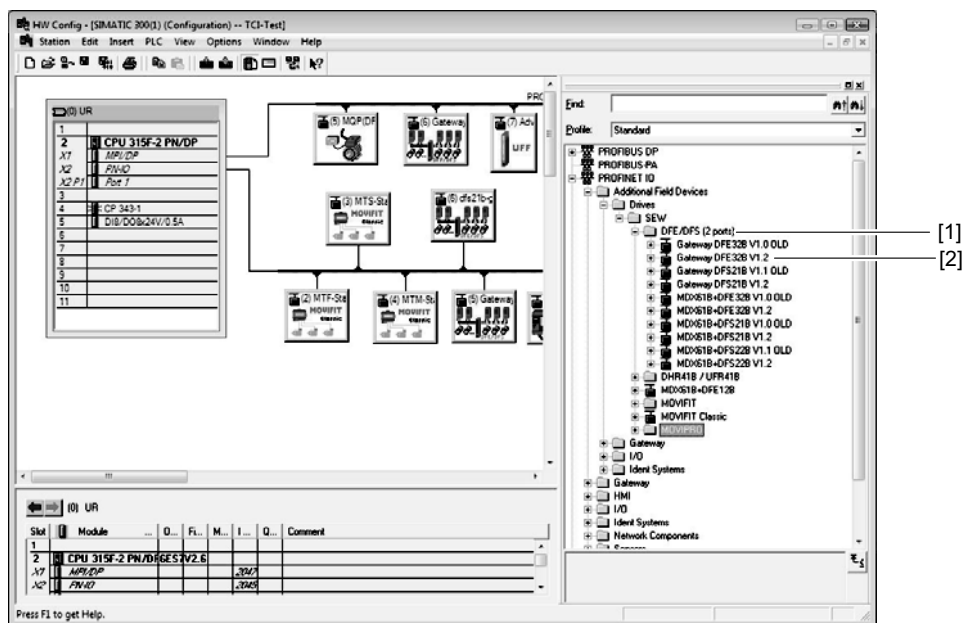

68074AEN

There are several entries.

- Copy the required entry to the PROFINET IO system via drag & drop:
 - Select "Gateway DFE32B V1.2" [2] if your controller supports topology detection.
 - Select "Gateway DFE32B V1.2 **ALT**" if your controller does **not** support topology detection.
- Assign the name of the PROFINET node.
This name must later correspond to the PROFINET unit name specified in the DFE32B.



Project Planning with PROFINET

Project planning for the PROFINET IO controller

- The inverters connected to the gateway are represented in PROFINET as of slot 2. Delete the entries for the respective slots depending on the number of connected inverters (e.g. slot 2 to slot 7 for a configuration of 5 inverters).
- Move the entry AS 1 Drive (1x3PD) to the free slots via drag & drop.
- Specify the IO and periphery addresses for the configured drives and save your configuration.

The slot model is used for project planning with PROFINET. Each slot is assigned to a DFE32B fieldbus interface. The following segmentation is used for the gateway function of the DFE32B.

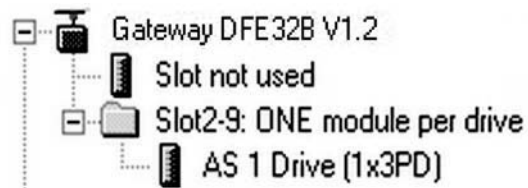

12190AEN

Slot 1 is not currently not used. Slots 2 ... 9 are assigned process data channels for connected devices and 3 process data per drive.

- Extend your user program by data exchange with the new units.
- Process data transfer is consistent. SFC14 and SFC15 can be used to transfer process data.



Node configuration

When the individual slots are configured, the new node has to be configured with further settings. Double-click the device symbol of the new node to open the following dialog.

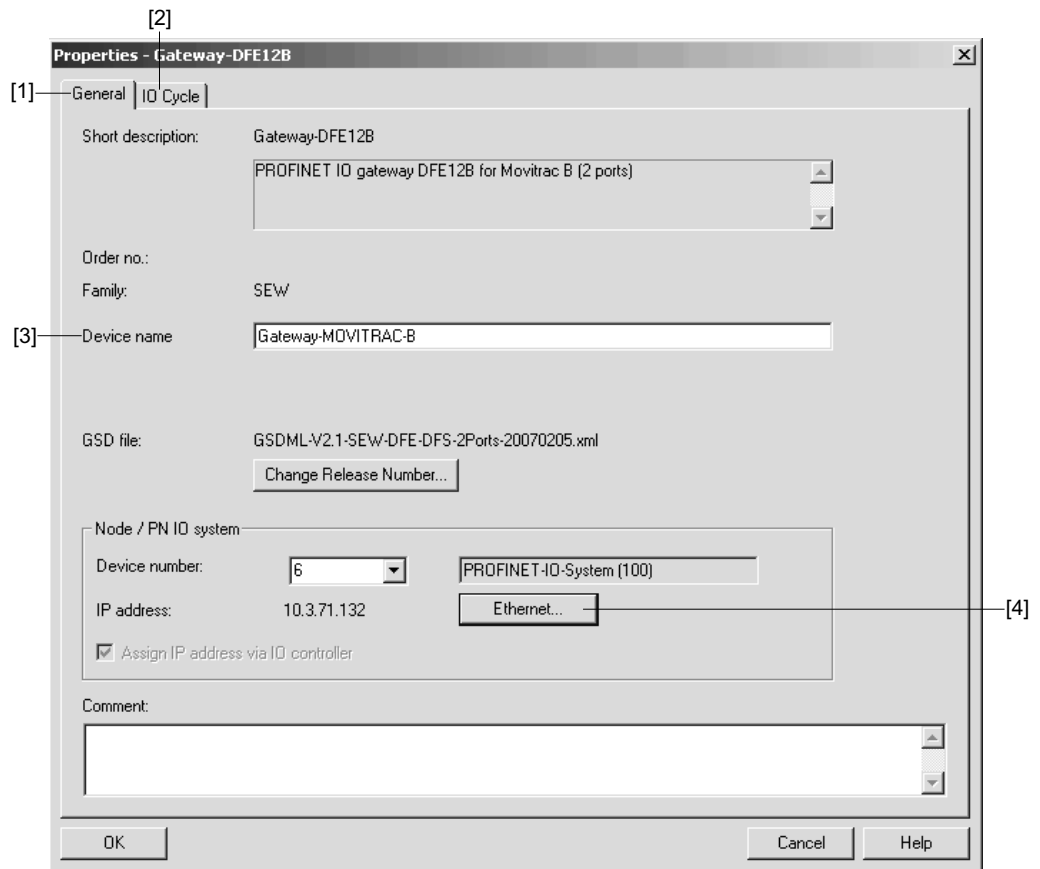

62336AEN

[1]	"General" tab
[2]	"IO cycle" tab
[3]	"Device name" edit box
[4]	[Ethernet] button

- Enter the device name mentioned above in the "Device name" edit box [3] on the "General" tab [1]. Note that the name is case-sensitive.



Project Planning with PROFINET

Project planning for the PROFINET IO controller

- Click [Ethernet] [4] in the "Node/PK-IO System" section to enter the IP address assigned before (→ following figure).

Properties - Ethernet interface Gateway-DFE32B

General Parameters

IP address:

Subnet mask:

Subnet:

- not networked ---
- Ethernet(1)

Gateway:

Do not use router

Use router

Address:

New... Properties... Delete

OK Cancel Help

11732AEN

- On the "IO Cycle" tab [2], you can specify an update time for the node to update its process data. The DFE32B option in MOVITRAC[®] B supports a minimum update time of 4 ms (→ following figure).

Properties - Gateway-DFE32B

General IO Cycle

Update time: ms

Number of accepted update cycles with missing IO data:

Watchdog time: ms

11733AEN



Starting the controller

Load the project planning in the SIMATIC S7 and start the module. The Error LED of the controller should now go out.

The LEDs of the DFE32B option should have the following statuses:

- RUN LED: lights up green
- BUS FAULT LED: off
- Link/Activity LED: Flickering

If this is not the case, check the project planning, especially the device name and the IP address of the node.

Application example

8 MOVITRAC® B frequency inverters are to be operated at a variable speeds in this example. The information between PLC and the individual inverters is exchanged via 3 process data.

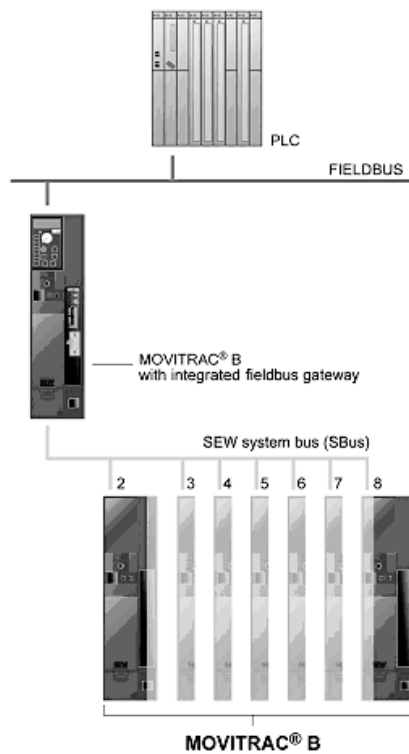

62260AXX



Project Planning with PROFINET

Project planning for the PROFINET IO controller

The following figure shows the corresponding PROFINET parameterization.

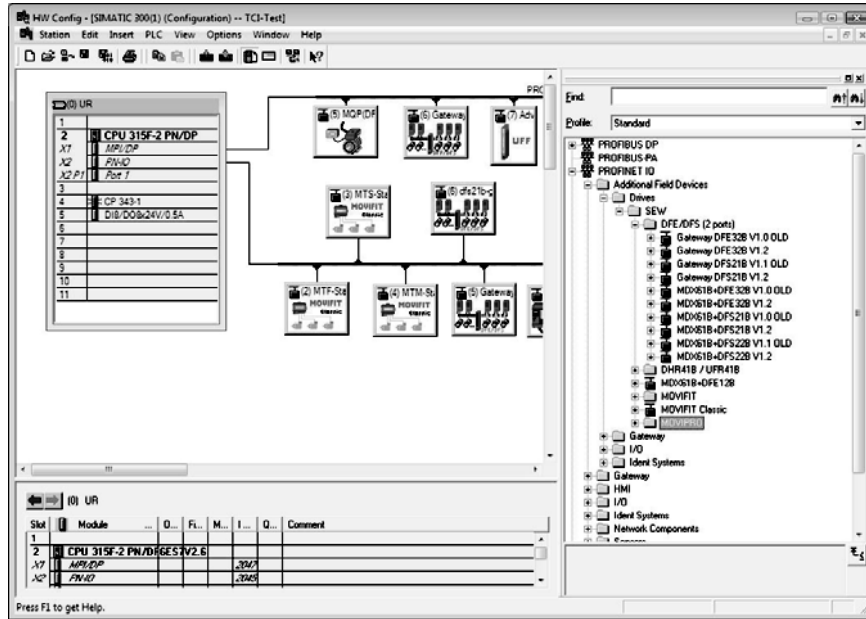

68073AEN



5.2 Auto setup for gateway operation

The Auto setup function enables startup of the DFE32B as gateway to be performed without a PC. It is activated via the auto setup DIP switch (see section "Installing the DFE32B/UOH11B gateway", page 18).

INFORMATION



Switching on the Auto-setup DIP switch causes the function to be performed once. **The Auto setup DIP switch must then remain in the ON position.** The function can be reactivated by turning the DIP switch off and back on again.

As a first step, the DFE32B searches for drive inverters on the SBus below its hierarchical level. This process is indicated by the **H1** LED (system error) flashing briefly. Different SBus addresses must be set for the drive inverters (P813). We recommend assigning the addresses beginning with address 1 in ascending order based on the arrangement of inverters in the switch cabinet. The process image on the fieldbus side is expanded by three words for each detected drive inverter.

The **H1** LED remains lit if no drive inverter was located. A total of up to eight drive inverters is taken into account. The following figure shows the process image for three drive inverters with three words each of process output data and process input data.

After the search is completed, the DFE32B periodically exchanges three process data words with each connected drive inverter. The process output data are fetched from the fieldbus, divided into blocks of three and transmitted. The drive inverters read the process input data, put them together and send them to the fieldbus master.

The cycle time of the SBus communication is 2 ms per node at a baud rate of 500 kBit/s without any additional engineering activities.

For an application with 8 inverters on the SBus, the cycle time of the process data update is then $8 \times 2 \text{ ms} = 16 \text{ ms}$.

INFORMATION



Perform auto setup again in the following cases, since the DFE32B stores these values once during auto setup. All devices installed at the SBus must be switched on. At the same time, the process data assignments of the connected drive inverters may not be changed dynamically after Auto setup.

- If you change the process data assignment of the drive inverters connected to the DFE32B.
- If you changed the SBus address of one of the connected devices.
- If you add or remove devices.



Project Planning with PROFINET

Auto setup for gateway operation

The following illustration shows the data exchange between the PLC, the DFE32B option and the inverter.

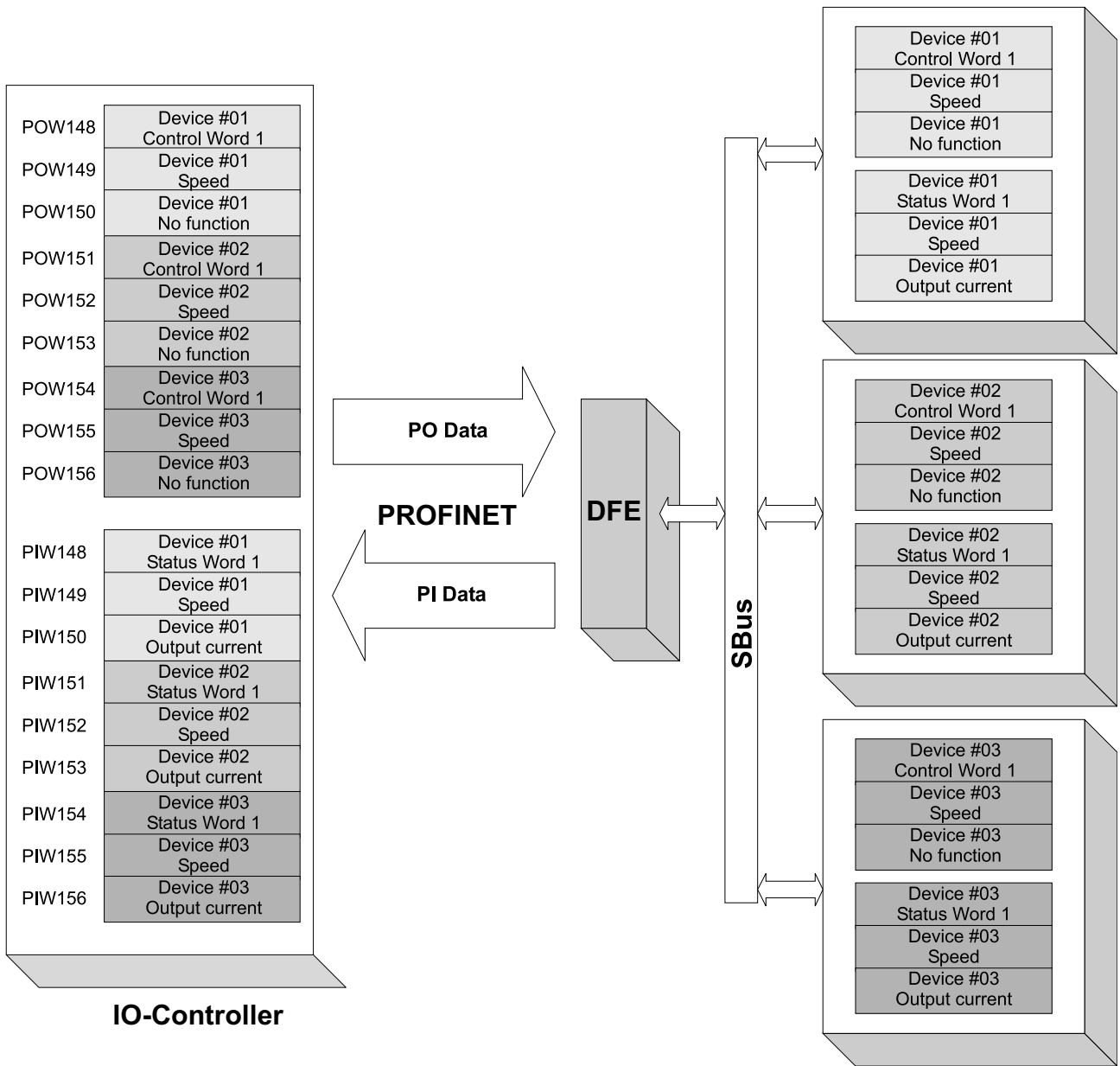

62322AXX



5.3 Setting the MOVIDRIVE® MDX61B

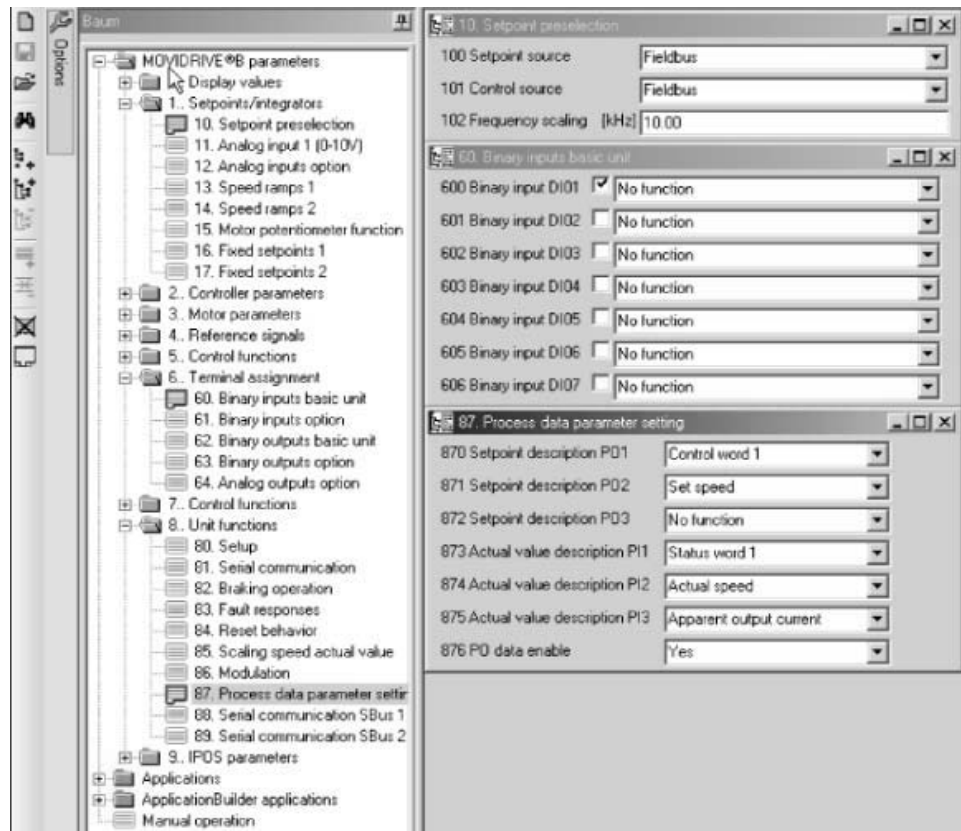

11638AEN

To control the drive inverter via PROFINET, you must first switch the drive inverter to control signal source (P101) and setpoint source (P100) = FIELDDBUS. The FIELDDBUS setting means the drive inverter parameters are set for control and setpoint entry via PROFINET. The MOVIDRIVE® drive inverter then responds to the process output data transmitted from the master programmable controller.

The parameters of the MOVIDRIVE® drive inverter can be set straight away via PROFINET without any further settings once the PROFINET option card has been installed. For example, all parameters can be set by the master programmable controller after power-on.

Activation of the control signal source and setpoint source FIELDDBUS is signaled to the machine control using the "Fieldbus mode active" bit in the status word.

For safety reasons, you must also enable the drive inverter at the terminals for control via the fieldbus system. Therefore, you must wire and program the terminals in such a way that the drive inverter is enabled via the input terminals. For example, the simplest way of enabling the drive inverter at the terminals is to connect the DI00 (function /CONTROL INHIBIT) input terminal to a DC +24 V signal and to program input terminals DI01 ... DI03 to NO FUNCTION.



5.4 Setting the MOVITRAC® B

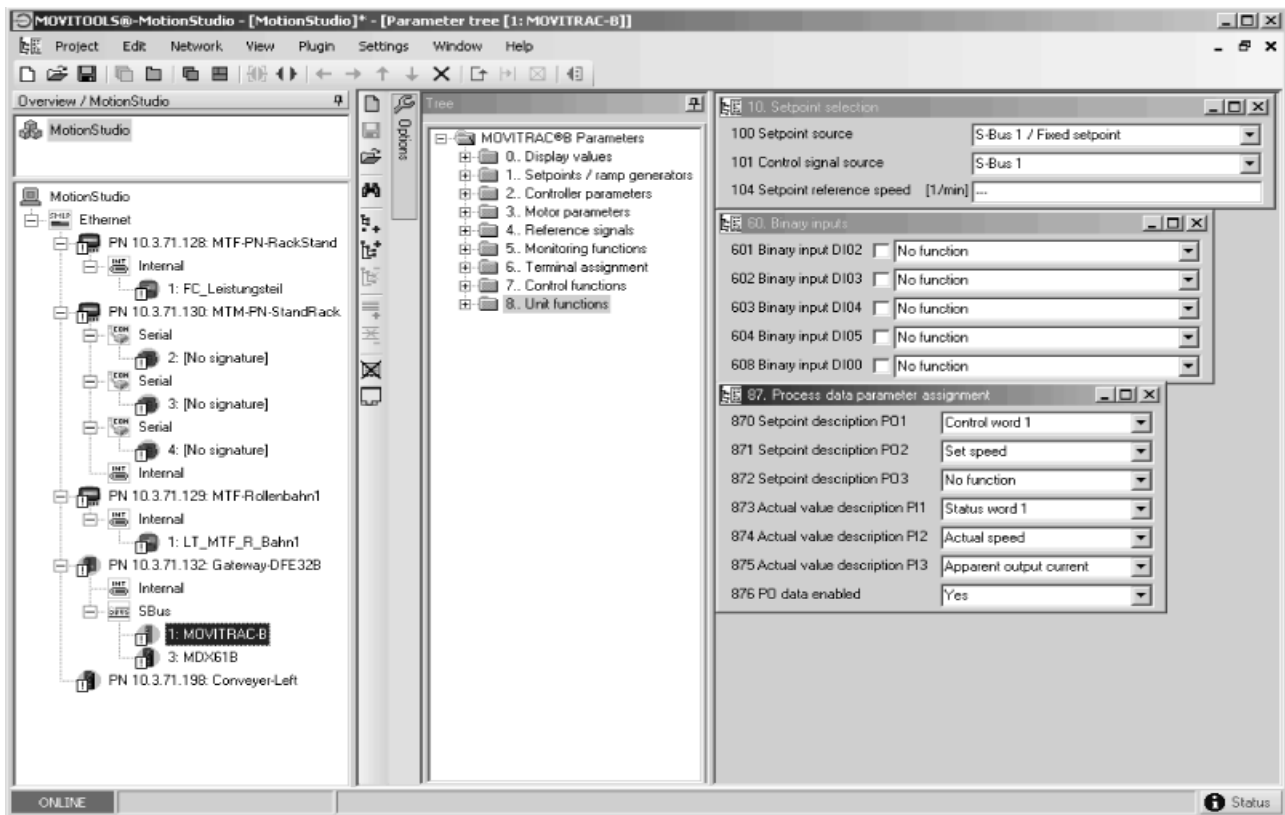

11736AEN

To control the frequency inverter via PROFINET, you must switch the drive inverter to *control signal source* (*P101*) and *setpoint source* (*P100*) = SBus beforehand. The SBus setting means the inverter parameters are set for control and setpoint entry via gateway. The MOVITRAC® frequency inverter then responds to the process output data transmitted from the master programmable controller.

It is necessary to set the SBus1 timeout interval (*P815*) to a value other than 0 ms for the MOVITRAC® frequency inverter to stop if faulty SBus communication is encountered. We recommend a value in the range 50 to 200 ms.

Activation of the control signal source and setpoint source SBus is signaled to the machine control using the "SBus mode active" bit in the status word.

For safety reasons, you must also enable the inverter at the terminals for control via the fieldbus system. Consequently, you must wire and program the terminals in such a way that the inverter is enabled via the input terminals. The simplest way of enabling the frequency inverter at the terminals is, for example, to connect the DI01 (function CW/STOP) input terminal to a DC +24-V signal and to set the remaining input terminals to NO FUNCTION.

INFORMATION



- Set the parameter *P881 SBus address* to values between 1 and 8 in ascending order. 8.
- The SBus address 0 is used by DFE32B gateway and therefore must not be used.
- Set *P883 SBus timeout* to values between 50 and 200 ms.



5.5 Startup procedure for MDX61B with DFE32B option

The following sections will describe the the startup procedure for a MOVIDRIVE® B with the DFE32B PROFINET IO option step-by-step.

5.5.1 Preliminary work

Step 1: Install the required software

1. FTDI driver for USB11A programming interface
 - Connect USB11A to the PC. Windows hardware detection installs the required FTDI driver.
 - The FTDI driver is available on the Software ROM 7 or on the SEW website.
2. GSD file: SEW-DFE32B-2-Port_V2.1-JJJJ.MM.TT.xml
3. MOVITOOLS® MotionStudio version 5.40 or later.

Step 2: Installing the devices

1. Install MOVIDRIVE® MDX60B/61B according to operating instructions:
 - Supply system cable
 - Motor cable
 - Braking resistor
 - DC 24 V backup voltage
2. Install PROFINET and connect DFE32B to PROFINET.

5.5.2 Starting up MOVIDRIVE® B with DC 24 V or AC 400 V

Step 1: Configuring MOVIDRIVE® B

1. Start MOVITOOLS® MotionStudio and open a new project.
Specify a project name and assign USB11A programming interface according to serial COM interface.
 - When the USB11A programming interface is connected to the PC for the first time, Windows hardware detection installs the required FTDI driver
 - If USB11A is not recognized, check the assignment to the COM interface. The matching COM port is marked by "USB".
2. Connect the PC to MOVIDRIVE® B via USB11A programming interface.
3. Perform a unit scan. To do so, select the unit using the mouse button and make a right-mouse click to open the context menu. Then choose [Startup] / [Parameter tree] from the menu.
4. Set *P100 setpoint source* and *P101 control signal source* to "Fieldbus".
5. For simple control via fieldbus, the binary inputs can be set to "No Function" via parameters P601 ... P608.
6. Check the parameterization for the process data (P87x). The parameters for control word and status word must be set. Set *P876 PO data enable* to "Yes".



Step 2: Configuring PROFINET

1. Start the control manufacturer's software to configure the hardware (e.g. STEP 7-HWKONFIG).
2. Install the GSD file if necessary (→ section "Preliminary work")
3. Check whether PC and control are located in the same subnetwork:
 - Are the IP addresses of PC and CPU identical up to the lowest byte?
 - Is the subnet mask identical?
4. Check whether a TCP/IP communication can be established with the controller.
5. Carry out the PROFINET configuration according to this manual.
 - Assign PROFINET device name
 - Assign IP configuration if necessary
 - Perform process data configuration
 - Load the project planning to the controller
6. The BUS FAULT LED of the DFE32B option is off when PROFINET is successfully configured. Process data is now being exchanged.
7. Extent control program and set up process data exchange to MOVIDRIVE® B.
8. Start MOVITOOLS® MotionStudio and open a new project. Set up "Ethernet" as communication interface.
 - Alternatively, MOVITOOLS® MotionStudio can be operated via serial communication with USB11A. Connect PC with MOVIDRIVE® B.
9. Perform a unit scan.
10. Select MOVIDRIVE® B, make a right mouse click and choose [Diagnostic] / [Bus monitor] from the context menu. Check whether the project data exchange between control and MOVIDRIVE® is working.
11. Switch on the supply voltage and enable MOVIDRIVE® B at the terminals (DI00=1). Activate unit enable via control word 1 = 0x0006 .
 - If MOVIDRIVE® B remains in "No Enable" condition, check terminal assignment (parameter group P60x) and supply further binary inputs with DC 24 V if required.



5.6 Startup procedure for the DFE32B option as gateway

The following sections will describe the the startup procedure for a MOVITRAC® B with the DFE32B PROFINET IO option as gateway step-by-step.

5.6.1 Preliminary work

Step 1: Install the required software

1. FTDI driver for USB11A programming interface
 - Connect USB11A to the PC. Windows hardware detection installs the required FTDI driver.
 - The FTDI driver is available on the Software ROM 7 or on the SEW website.
2. GSD file: SEW-DFE32B-2-Port_V2.1-JJJJ.MM.TT.xml
3. MOVITOOLS® MotionStudio version 5.40 or later.

Step 2: Installing the devices

1. Install MOVITRAC® B according to the operating instructions:
 - Supply system cable
 - Motor cable
 - Braking resistor
 - DC 24 V backup voltage
2. Install PROFINET and connect gateway to PROFINET.
3. Install the system bus according to this manual.
4. Activate SBus terminating resistor at final node.



5.6.2 Starting up units with DC 24 V or AC 400 V

Step 1: Configure MOVITRAC® B

1. Start MOVITOOLS® MotionStudio and open a new project.
Specify a project name and assign USB11A programming interface according to serial COM interface.
 - When the USB11A programming interface is connected to the PC for the first time, Windows hardware detection installs the required FTDI driver
 - If USB11A is not recognized, check the assignment to the COM interface. The matching COM port is marked by "USB".
2. Connect the PC to MOVITRAC® B via USB11A programming interface.
3. Perform a unit scan. To do so, select the unit using the mouse button and make a right-mouse click to open the context menu. Then choose [Startup] / [Parameter tree] from the menu.
4. Set the parameters for *P881 SBus address* in ascending order (1 ... 8) unequal to 0
Set *P883 SBus timeout interval* to 50 ... 200 ms
5. Set *P100 setpoint source* to "SBus1/fixed setpoint" and *P101 control signal source* to "SBus1".
6. For simple control via fieldbus, the binary inputs can be set to "No Function" via parameters P601 ... P608.
7. Check the parameterization for the process data (P87x). The parameters for control word and status word must be set. Set *P876 PO data enable* to "Yes".
8. Repeat steps 2 to 7 for the individual units connected to the SBus.
9. Activate Auto setup function via "AS" DIP switch of the DFx gateway. Set "AS" DIP switch to 1. H1 LED flashes during the scan and goes out after successful completion.
10. Connect the PC to DFx gateway via USB11A programming interface.
11. Perform a unit scan. The DFx gateway and all units installed at the SBus must be accessible now.
12. Select DFx gateway and open the context menu with a right mouse click. Choose [Diagnostics] / [Monitor Fieldbus Gateway DFx] from the menu. Go to the "Gateway Configuration" tab page and check whether the "Auto setup" function has recognized all units. If not, check
 - the SBus installation
 - Whether the terminating resistor is connected to the final unit
 - The SBus addresses of the individual units



Step 2: Configuring PROFINET

1. Start the control manufacturer's software to configure the hardware (e.g. STEP 7-HWKONFIG).
2. Install the GSD file if necessary (→ section "Preliminary work")
3. Check whether PC and control are located in the same subnetwork:
 - Are the IP addresses of PC and CPU identical up to the lowest byte?
 - Is the subnet mask identical?
4. Check whether a TCP/IP communication can be established with the controller.
5. Carry out the PROFINET configuration according to this manual.
 - Assign PROFINET device name
 - Assign IP configuration if necessary
 - Perform process data configuration
 - Load the project planning to the controller
6. The BUS FAULT LED of the DFE32B option is off when PROFINET is successfully configured. Process data is now being exchanged.
7. Extend control program and set up process data exchange to DFX gateway.
8. Start MOVITOOLS[®] MotionStudio and open a new project. Set up "Ethernet" as communication interface.
 - Alternatively, MOVITOOLS[®] MotionStudio can be operated via serial communication with USB11A. Connect PC with DFX gateway.
9. Perform a unit scan. DFX gateway and all units installed at the SBus must now be accessible if the MOVITRAC[®] B units have been configured beforehand.
10. Activate the DFX gateway via the mouse and start the "Monitor DFX Feldbus Gateway" tool via the right mouse button. Go to the Process data monitor window and check whether the process data exchange between controller and gateway is working.
11. Switch on the supply voltage and enable MOVITRAC[®] B at the terminals (DI01=1). Activate unit enable via control word 1 = 0x0006
 - If MOVITRAC[®] B remains in "No Enable" condition, check terminal assignment (parameter group P60x) and supply further binary inputs with DC 24 V if required.



6 Operating Behavior in Conjunction with PROFINET

6.1 Introduction

Classic fieldbus communication is enhanced by fast Ethernet technology as a physical transmission medium using PROFINET IO. Profinet supports real-time capable process communication as well as open communication via Ethernet TCP/IP. PROFINET distinguishes between three communication classes that differentiate in terms of efficiency and functionality.

Three communication classes

- **TCP/IP**
Open Ethernet TCP/IP communication without real-time requirements (e.g. Web technology)
- **RT (Real-Time)**
IO data exchange between automation units in real-time (>1 ms).
- **IRT (Isochronous Real-Time)**
Isochronous real-time communication for synchronized IO data exchange (e.g. for motion control applications - not for DFE32B option).

The DFE32B option meets the requirements of the PROFINET RT class and provides open communication via TCP/IP or UDP/IP.

Three unit classes

PROFINET IO differentiates between three unit types - "IO controller", "IO device" and "IO supervisor."

- **IO controller**
The IO controller undertakes the master function for the cyclic IO data exchange with the decentralized field units and is usually implemented as a communication interface of a controller. It is similar to a PROFIBUS DP master class 1. A PROFINET IO system can have several IO controllers.
- **IO device**
All field units of PROFINET IO that are controlled by an IO controller are designated as IO devices, e.g. I/O, drives, valve terminals, etc. IO devices are comparable with PROFIBUS DP slave nodes. The DFE32B option is a PROFINET IO device.
- **IO supervisor**
Programming devices/PC with corresponding engineering/diagnostic tools are designated as IO supervisors. IO supervisors have access to process and parameter data as well as alarm and diagnostic information.



Communication model

The communication model of PROFINET IO is based on the many years of experience with PROFIBUS DP-V1. The master slave access procedure was mapped on a provider-consumer model.

Several communication channels are used for the data exchange between IO controller and IO devices. The cyclic IO data and the event-driven alarms are transferred via real-time channels. The standard channel based on UDP/IP is used for parameterization, configuration and diagnostic information.

Unit model

The existing decentralized periphery of PROFIBUS DP has been enhanced for the device model. The device model is based on slot and subslot mechanisms where modular devices with slots can be implemented for modules and submodules. In this way, the slot and submodules are represented by subslots for the modules. These mechanisms also enable logical modularization, e.g. for a drive system (→ following figure).

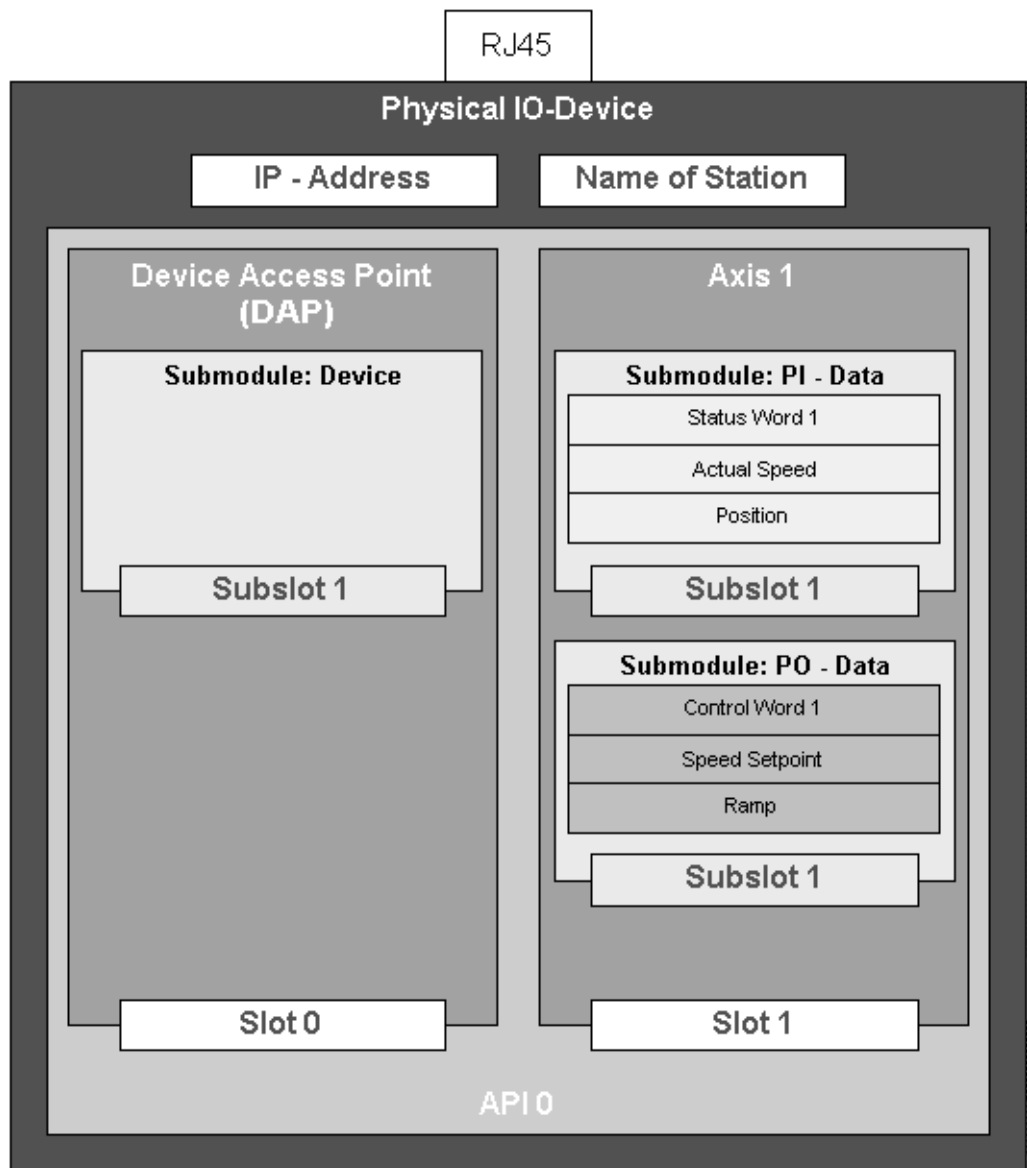

58645AXX



A single drive axle is represented as a module under PROFINET IO. Several submodules can be plugged into this module. The submodules determine the process data interface to the IO controller or the data traffic partner. Thus they have provider or consumer quality. The model provides the option to plug several modules into an IO device for multi-axis systems that have a common PROFINET IO interface. In this way, each module again represents a single axis. Slot 0 is used as a Device Access Point (DAP) and usually represents the IO device.

6.2 The integrated Ethernet switch

You can use the integrated Ethernet switch to achieve line topologies known from the fieldbus technology. Other bus topologies, such as star or tree, are also possible. Ring topologies are not supported.

INFORMATION



The number of industrial Ethernet switches connected to the line affects the telegram runtime. If a telegram passes through the units, the telegram runtime is delayed by the store & forward function of the Ethernet switch:

- For a telegram length of 64 bytes by approximately 10 μ s (at 100 Mbit/s)
- For a telegram length of 1500 bytes by approximately 130 μ s (at 100 Mbit/s)

This means that the more units a telegram has to pass through, the higher the telegram runtime is.

Auto-crossing

The two ports leading out of the Ethernet switch have auto-crossing functionality. This means that they can use both patch and cross-over cables to connect to the next Ethernet node.

Auto-negotiation

The baud rate and the duplex mode is negotiated by both Ethernet nodes when establishing the connection. For this purpose, both Ethernet ports of the PROFINET connection support an auto-negotiation functionality and work with a baud rate of either 100 Mbit or 10 Mbit in full duplex or half-duplex mode.

INFORMATION



PROFINET IO networks must be operated at a baud rate of 100 Mbit in full duplex mode.

Monitoring the LINK status

Both ports allow for a monitoring of the LINK status. You can set up this function via the STEP 7 hardware configuration as follows:

- Select slot 0 in STEP 7.
- Select [Object properties] from the context menu.
- Select the "Parameters" tab.

Only set the monitoring for the port that sends data packages to other nodes and not to the control. If a LINK DOWN is detected when the monitoring function is switched on, the PROFINET device sends a diagnostics alarm to the control via the other port (→ section "PROFINET alarms using the example of MOVIDRIVE® B")

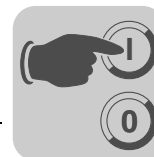

6.3 Process data configuration

For the DFE32B option, Slot 1 must be set to "slot not used". Slot 2 allows for modules with 1 to 10 I/O words. After the unit has been switched on and before the IO controller establishes the communication, the configuration is set to 3 process data words I/O. It can be changed by the IO controller while the communication is being established. The current configuration is displayed in *P090 PD configuration*.

Permitted configurations

ID	Process data length
101	1 I/O process data word
102	2 I/O process data words
103	3 I/O process data words
104	4 I/O process data words
105	5 I/O process data words
106	6 I/O process data words
107	7 I/O process data words
108	8 I/O process data words
109	9 I/O process data words
110	10 I/O process data words

The DAP (Device Access Point) is designated as ID 100 (slot 0, subslot 1)

INFORMATION



The project planning for the DFE32B option is compatible to the DFE12B option. That means that you do not have to change the project planning when you replace the DFE12B option with the DFE32B option. The DFE32B option then accepts 1 ... 10 process data words 10 process data words.



6.4 MOVIDRIVE® MDX61B – control

The drive inverter is controlled via the process data channel which is up to 10 I/O words in length. These process data words may be mapped in the I/O or peripheral area of the controller if a programmable controller is used as IO controller and can be addressed as usual.

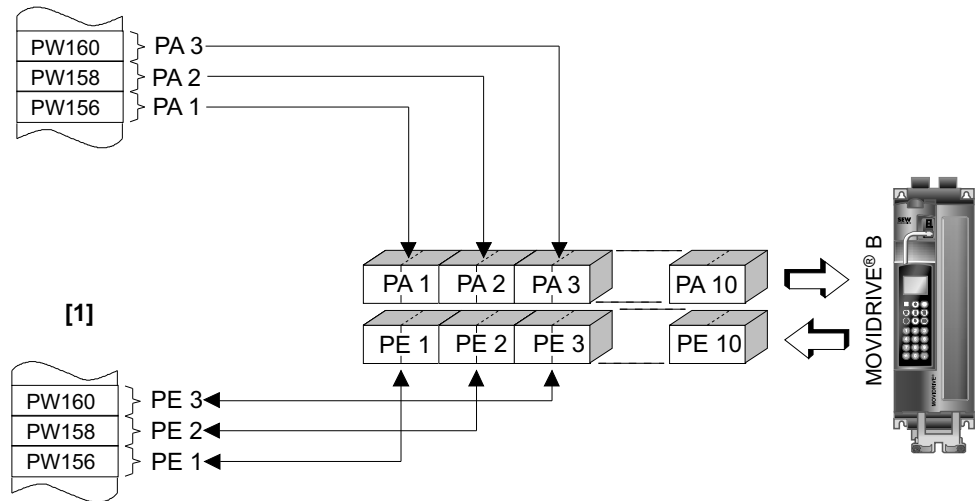

62321AXX

Figure 2: Mapping PROFINET data in the PLC address range

[1] PLC address range

PI1 ... PI10 Process input data

PO1 ... PO10 Process output data

INFORMATION



For more information about controlling via the process data channel, in particular regarding the coding of the control and status word, refer to the Fieldbus Unit Profile manual.

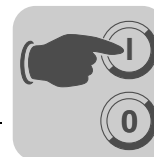

6.4.1 SIMATIC S7 with MOVIDRIVE® MDX61B – control example

The drive inverter is controlled via SIMATIC S7 depending on the selected process data configuration, either directly via load and transfer commands or via the special system functions *SFC 14 DPRD_DAT* and *SFC15 DPWR_DAT*.

In principle, S7 data lengths of 3 bytes or more than 4 bytes must be transmitted using system functions SFC14 and SFC15.

Consequently, the data in the following table applies:

Process data configuration	STEP 7 access via
1 PD	Load/transfer commands
2 PD	Load/transfer commands
3 PD	System functions SFC14/15 (length: 6 bytes)
6 PD	System functions SFC14/15 (length: 12 bytes)
10 PD	System functions SFC14/15 (length: 20 bytes)

6.4.2 PROFINET timeout (MOVIDRIVE® MDX61B)

If the data transfer via PROFINET is faulty or interrupted, the response monitoring time in MOVIDRIVE® elapses (if configured in the IO control). The **BUS FAULT** LED lights up or flashes to indicate that no new user data is being received. At the same time, MOVIDRIVE® performs the error response selected with *P831 Fieldbus timeout response*.

P819 Fieldbus timeout displays the response monitoring time specified by the IO controller during the PROFINET startup. The timeout can only be changed via the IO controller. Although modifications made via the keypad or MOVITOOLS® MotionStudio are displayed, they do not have any effect and are overwritten when the PROFINET is next started up.

6.4.3 Fieldbus timeout response (MOVIDRIVE® MDX61B)

Parameter *P831 Response Fieldbus Timeout* is used to set the error response that is triggered via the fieldbus timeout monitoring function. The setting made here must correspond to the setting in the master system (S7: response monitoring).



6.5 MOVITRAC® B (gateway) – control

The inverter is controlled via the process data channel, which is up to 3 I/O words in length. These process data words may be mapped in the I/O or peripheral area of the controller if a programmable controller is used as IO controller and can be addressed as usual.

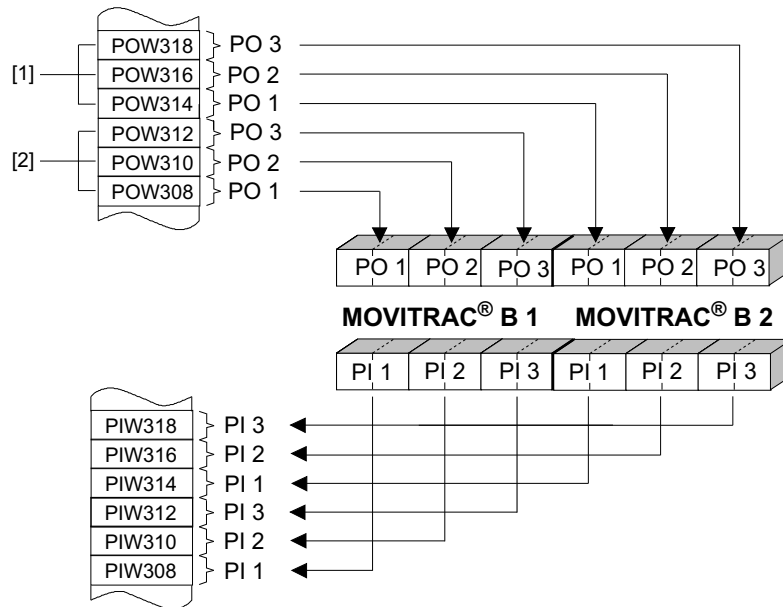
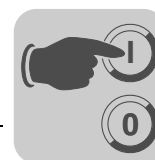

Figure 3: Mapping PROFINET data in the PLC address range

58612AXX

- [1] Address range MOVITRAC® B, unit 2
- [2] Address range MOVITRAC® B, unit 1

PO = process output data / PI = process input data



6.5.1 Control example for SIMATIC S7 with MOVITRAC® B (gateway)

The drive inverter is controlled using SIMATIC S7 in accordance with the selected process data configuration either directly using load and transfer commands or by means of special system functions SFC 14 DPRD_DAT and SFC15 DPWR_DAT.

In principle, S7 data lengths of 3 bytes or more than 4 bytes must be transmitted using system functions SFC14 and SFC15.

Process data configuration	STEP 7 access via
3 PD ... 24 PD	System functions SFC14/15 (Length 6 ... 48 bytes)
Param + 3 PD ... 24 PD	System functions SFC14/15 (Length 6 ... 48 bytes for PD + 8 bytes for parameter)

6.5.2 SBus timeout

If one or more drive inverters on the SBus can no longer be addressed by the DFE32B, the gateway displays error code *F11 System error* in status word 1 of the corresponding inverter. The **H1** LED (system error) lights up, and the error is also displayed via the diagnostics interface. It is necessary to set the *SBus timeout interval (P815)* of the MOVITRAC® B system error to a value other than 0 for the inverter to stop. The error resets itself in the gateway, which means the current process data are exchanged immediately after communication is restarted.

6.5.3 Unit errors

The gateways detect a series of errors during the self test and respond by locking themselves. For the exact error responses and according measures please refer to the error list (→ "Error list in gateway operation"). A hardware defect causes error *F111 system error* to be displayed on the fieldbus process input data for status words 1 of all drive inverters. The **H1** LED (system error) at the DFE is lit. The exact error code of the gateway status can be displayed via the diagnostics interface with MOVITOOLS® MotionStudio (Tool "Status").

6.5.4 Fieldbus timeout response of the DFE32B in gateway operation

You can set how the gateway should respond in case of timeout using the *P831 Fieldbus timeout response* parameter.

No response	The drives on the subordinate SBus continue with the last setpoint value. These drives cannot be controlled when the PROFIBUS communication is interrupted.
PA_DATA = 0 (factory setting)	The rapid stop is activated for all drives that have a process data configuration with control word 1 or 2 when a PROFINET timeout is detected. For this, the gateway sets the bits 0 to 2 of the control word to 0. The drives are stopped via the rapid stop ramp.



6.6 SIMATIC S7 Sample program

INFORMATION



This example is a special and free service that demonstrates only the basic approach to generating a PLC program. SEW is not liable for the contents of the sample program.

In this example, the project planning for MOVIDRIVE® B or MOVITRAC® B has the process data configuration "3 PD" on input addresses PIW576... and output addresses POW576....

A data block DB3 is created with about 50 data words.

When SFC14 is called, the process input data is copied to data block DB3, data words 0, 2 and 4. When SFC15 is called after the control program has been processed, the process output data are copied from data words 20, 22 and 24 to the output address POW 576 ...

Note the length specification in bytes for the RECORD parameter. The length information must correspond to the configured length.

Refer to the online help for STEP 7 for further information about the system functions.

```
//Start of cyclical program processing in OB1
BEGIN
NETWORK
TITLE = Copy PI data from inverter to DB3, words 0/2/4
CALL SFC 14 (DPRD_DAT) //READ IO DeviceRecord
LADDR := W#16#240 //Input address 576
RET_VAL:= MW 30 //Result in flag word 30
RECORD := P#DB3.DBX 0.0 BYTE 6 //Pointer

NETWORK
TITLE =PLC program with drive application
// PLC program uses the process data in DB3 for
// drive control

L DB3.DBW 0//Load PI1 (status word 1)
L DB3.DBW 2 //Load PI2 (actual speed value)
L DB3.DBW 4 //Load PI3 (no function)

L W#16#0006
T DB3.DBW 20//Write 6hex to PO1 (control word = enable)
L 1500
T DB3.DBW 22//Write 1500dec to PO2 (speed setpoint = 300 rpm)
L W#16#0000
T DB3.DBW 24//Write 0hex to PO3 (however, it has no function)

//End of cyclical program processing in OB1
NETWORK
TITLE =Copy PO data from DB3, word 20/22/24 to inverter
CALL SFC 15 (DPWR_DAT) //WRITE IO Device Record
LADDR := W#16#240 //Output address 576 = 240hex
RECORD := P#DB3.DBX 20.0 BYTE 6 //Pointer to DB/DW
RET_VAL:= MW 32 //Result in flag word 32
```



6.7 PROFINET alarms using the example of MOVIDRIVE® B

The DFE32B supports diagnostics alarms in case of a unit error. These diagnostic alarms are switched off at the factory. Proceed as follows to enable the diagnostics alarms in STEP 7 HWKONFIG (→ following figure).

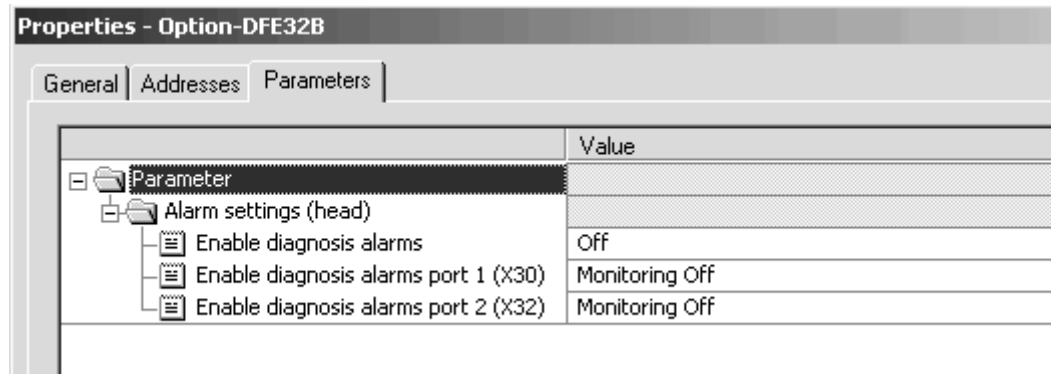

62269AEN

Diagnostics alarm of the MOVIDRIVE®

- Select slot 2 of DFE32B.
- Press the right mouse button and select [Object properties] or double-click on the slot. The "DFE32B properties" window opens.
- Activate the "Parameters" tab.
- Set the diagnostics alarms to "ON" and confirm with [OK].

In case of an error of the MOVIDRIVE®, a diagnostics alarm is generated and you can read the error message of the MOVIDRIVE® in plain text.

Diagnostics alarm of the integrated switch

- Select slot 0 of DFE32B.
- Press the right mouse button and select [Object properties] or double-click on the slot. The "DFE32B properties" window opens.
- Activate the "Parameters" tab. Set "Alarm port 1" or "Alarm port 2" to "ON" and click [OK]. In a line topology, the respective port of the Ethernet node must be monitored that leads to the subsequent Ethernet node (coming from the PLC).

The DFE32B uses this setting to monitor the unit communication with adjacent nodes. A diagnostics alarm is generated if the DFE32B detects an inactive partner at port 1 or 2.



Operating Behavior in Conjunction with PROFINET

PROFINET alarms using the example of MOVIDRIVE® B

A unit error of the MOVIDRIVE® B or the integrated switch results in a diagnostics alarm being sent to the SIMATIC control as a so-called "incoming event". The "SF" LED of the controller lights up red. You can determine the cause of the error in STEP 7 HWKONFIG. Go to ONLINE, mark the symbol of the DFE32B and check the module information via the context menu (right mouse button).

The screenshot displays the SIMATIC Manager HW Config interface. The main window shows a rack configuration with a CPU 317-2 and various modules. A diagnostics alarm is active, and the 'Module Information - SEW' dialog is open. The 'IO Device Diagnostics' tab is selected, showing the following information:

- Path: ProfinetRack\SIMATIC 300-Station\CPU 317-2
- Operating mode of the CPU: RUN
- Status: Error
- IO Controller Device Number: 0
- Manufacturer's ID: 16# 010A
- Device Identification: 16# 0001

The 'Channel-Specific Diagnostics' table shows the following error:

Slot	Channel ...	Error
1		F26 External terminal

The 'Help on Channel-specific Diagnostics' dialog is also open, providing the following information:

- Diagnostic row: F26 External terminal
- Help: Possible cause: Read in external fault signal via programmable input.

Buttons for 'Close', 'Update', 'Print...', and 'Help' are visible at the bottom of the 'Module Information' dialog.

58647AXX

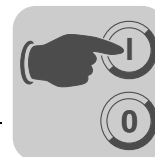

6.8 PROFINET configuration with topology detection

6.8.1 Introduction

The PROFINET technology detection allows for projecting and monitoring the structure of the network with the PROFINET IO controller in addition to the PROFINET IO devices.

The so-called "Physical device (PHDEV)" is the starting point for project planning. PDEV is a model for the Ethernet interface and can be found in slot 0 in the project planning with an "Ethernet interface" subslot and one subslot for each Ethernet port.

The Ethernet ports made visible in this way can be connected to the project planning tool. The result is an image of the desired Ethernet routing for the plant. This image is stored in the PROFINET IO controller.

In order to be able to determine the real plant topology, the PROFINET IO devices must support the so-called LLDP (Link Layer Discovery Protocol). The PROFINET IO devices exchange information with the neighboring PROFINET IO devices via LLDP. Via LLDP, each PROFINET IO device cyclically sends information on its own PROFINET device name and port number. The neighboring unit receives and stores this information. Now a PROFINET IO controller can read the stored information from the PROFINET IO devices, thus determining the real plant topology.

By comparing the projected topology with the real topology, you can detect any missing or incorrectly wired PROFINET IO devices and localize them in the plant.

Apart from cabling you can still determine the transmission characteristics for the ports. For example, you can set an "Auto-negotiation" port to "100 Mbit full duplex". The settings will be monitored.

SNMP (Simple Network Management Protocol) as a protocol for network diagnostics extends the topology detection with standard diagnostics mechanisms from the IT area.



6.8.2 Creating a PROFINET project and starting the topology editor

The following section describes the the project planning procedure for a PROFINET topology with the SIMATIC STEP 7 topology editor. There are various ways to perform project planning in SIMATIC STEP 7. This example will focus on **one** approach.

1. In STEP 7 HW Config, import the PROFINET devices from the hardware catalog into the PROFINET network as usual.

Make sure that the PROFINET IO controller supports the topology detection. The controller manufacturer will provide according information.

The hardware catalog contains several entries for each SEW interface marked as different versions. An entry marked with "ALT" does not support the PROFINET IO topology detection.

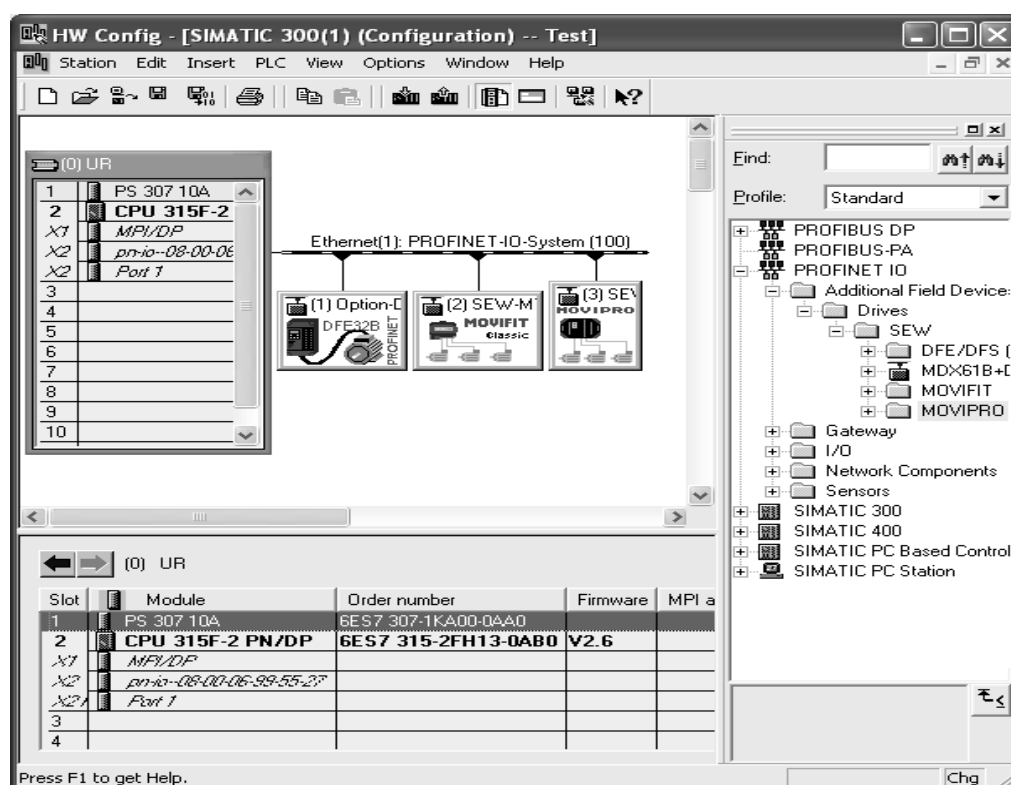

12186AEN

2. Right-click on the "PROFINET IO system" and select "PROFINET IO topology" from the context menu to start the topology editor.

The "Topology editor" window is displayed.

3. Proceed according to section "Specifying the topology and detecting faulty connections".



6.8.3 Specifying the topology and detecting faulty connections

Topology detection via topology editor

The topology detection is to compare the current topology (online topology) with the topology from the project planning (offline topology). Any deviations suggest faulty connections in the PROFINET network.

The following section provides an introduction as to how to use the topology editor to specify PROFINET nodes and detect faulty connections to ports.

Refer to the online help for a detailed description and important additional information (e.g. the color code of the comparison results).

Click [Help] to open the online help in the open topology editor.

Specifying the topology

Proceed as follows to specify the topology of nodes in a PROFINET network:

1. Start the topology editor according to section "Creating a PROFINET project and starting the topology editor".
2. Select the "Offline/online comparison" tab.

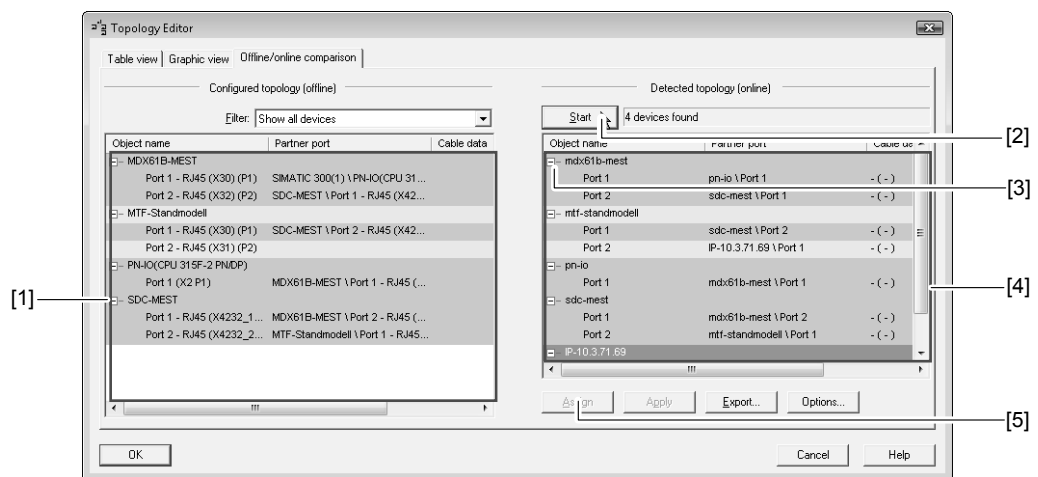

67798AEN

- [1] "Offline topology" list
 - [2] [Start] button
 - [3] Plus/minus symbol
 - [4] "Online topology" list
 - [5] [Assign] button
3. Click [Start] [2] to determine the online topology and compare it with the topology from project planning (offline topology).
The left part of the window displays the "Configured topology (offline)" list [1] and the right part displays the "Detected topology (online)" list [4].
The color code (the online help) and the order of the entries provide information regarding the comparison result.
 4. Make sure that the assignment corresponds to your requirements and is applied to the project planning.
 - If required, change the assignment of the devices. Mark the respective device in both lists and click [Assign] [5].



5. Make sure that the connection of the partner ports corresponds to your requirements and is applied to the project planning.
 - Click the plus sign [3] in front of the respective device in the right part of the window (online topology) [3] to have the partner ports displayed.
 - Change the connection of the partner ports if required. Mark the respective port and select [Apply port connection] from the context menu (right-click). To interrupt port connections, mark the respective port in the left part of the window and select [Interrupt port connection].
 - Repeat the procedure until all ports in the list are marked "green".

Detecting faulty connections

Faulty connections can be detected in the graphic view of the topology editor.

Proceed as follows to switch to the graphic view:

1. Start the topology editor according to section "Creating a PROFINET project and starting the topology editor".
2. Select the "graphic view" tab.

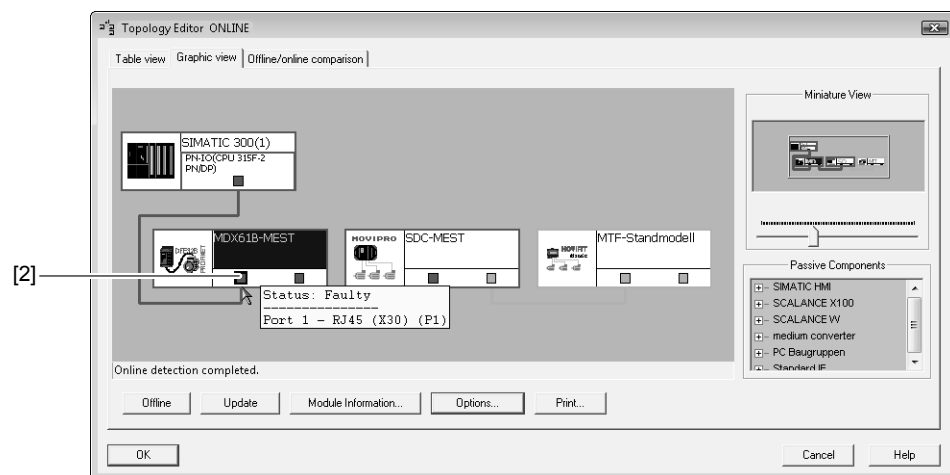

67799AEN

[1] Port with faulty connection

The graphic view provides a clear display of your PROFINET network (offline or online) with all devices and connected ports.

Faulty connections between ports are indicated by red lines.

3. Move the cursor over the port with the faulty connection [1] to display a status message for the error.

The present example illustrates a faulty connection between the controller and "port 1" of the first device.

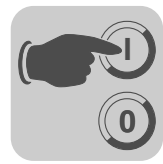

6.8.4 Changing the port properties

The two Ethernet ports of the PROFINET interface are set to "Automatic setup" by default. Observe the following for this default setup:

- Auto-negotiation and Auto-crossover are activated.
- The baud rate and the duplex mode are configured automatically.
- The neighboring port must also be set to "Automatic setup".
- You can use patch or crossover cables.

You may set a port to "100 Mbit/s full duplex". Observe the following for this setup:

- This setting must also be made for the port of the neighbor unit, otherwise it would work with 100 Mbit/s half duplex.
- If auto-crossover is deactivated, you have to use cross cables.

Proceed as follows to set a port to "100 Mbit/s full duplex":

1. Select a unit in STEP 7 HW Config.
2. Select the desired port on slot 0.
3. Right-click on the port and select "Object properties" from the context menu.
The "Object properties ..." window is displayed.
4. Select the "Options" tab [1].



67800AEN

- [1] "Auto-negotiation/auto-crossover" checkbox
[2] "Transmission medium/duplex" selection list

5. From the "Transmission medium/duplex" [2] select "TP/ITP with 100 Mbit/s full duplex".
6. Deactivate the "Auto-negotiation/auto-crossover" checkbox [1].



6.8.5 Topology diagnostics

Topology errors are reported to the PROFINET IO controller as diagnostics alarms. In the event of an error, the EXT-F-LED of the PROFINET IO controller is lit. The error is also indicated by a red cross [1] in STEP 7 HW Config.

Steckplatz	Baugruppe	Bestellnummer	E...	A...	D...
0	myMovifit	182x xxx x			1636
X1	Ethernet Interface				1637
P1	Port 1 - RJ45 (X30)				1637
P2	Port 2 - RJ45 (X31)				1636
1	Leerplatz				16368
2	MOVIFIT Status		518...		
3	Leerplatz				16367

68001AEN

[1] "Red cross" symbol for errors

Possible causes:

- Ethernet ports swapped
- Wrong port property settings
- Units cannot be addressed

Proceed as follows to display information on an error:

1. Select the unit or the respective slot.
2. Right-click on the port and select "Module status" from the context menu.
A window is displayed.
3. Select the "Communication diagnostics" tab.



6.8.6 Port statistics

Proceed as follows to display the port statistics for an Ethernet port in STEP 7 HW Config:

1. Click the "ONLINE → OFFLINE", to switch to the "Online" communication mode.
2. Select a unit.
3. Select the desired port on slot 0.
4. Right-click on the port and select "Module status" from the context menu.

The "Module status ..." window is displayed.

Select the "Statistics" tab [1].

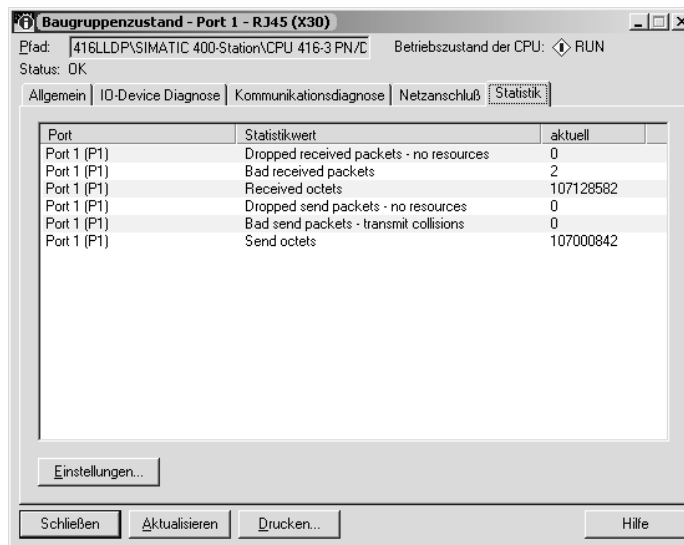

68002AEN

The following statistic values can be displayed:

- **Dropped received packets – no resources**
Shows the number of valid Ethernet packets dropped upon reception. A large number of dropped valid packets suggests a high load on the bus system. In this case, try to reduce the utilization by especially reducing the number of broadcast and multicast telegrams and reducing the IO cycle or the number of PROFINET units in a line if required.
- **Bad received packets**
Shows the number of faulty Ethernet packets. A high number suggests a bus error. In this case, check the cabling and shielding of the network.
- **Received octets**
Shows the number of received packets.



- **Dropped sent packets – no resource**

Shows the number of valid Ethernet packets dropped during transmission. A large number of dropped valid packets suggests a high load on the bus system. In this case, try to reduce the utilization by especially reducing the number of broadcast and multicast telegrams and reducing the IO cycle or the number of PROFINET units in a line if required.

- **Bad sent packets – transmit collisions**

Shows the number of Ethernet packets dropped due to collisions. There should be no collisions in a switched network.

- **Sent Octets**

Shows the number of transmitted packets.



7 Parameterization via PROFIdrive Data Set 47

7.1 Introducing PROFINET data sets

With "Read record" and "Write record", PROFINET offers acyclic services that can be used to transfer parameter data between the PROFINET controller (master) and a PROFINET device (slave). Via UDP (User Datagram Protocol), the priority of this data exchange is lower than the priority of the process data exchange.

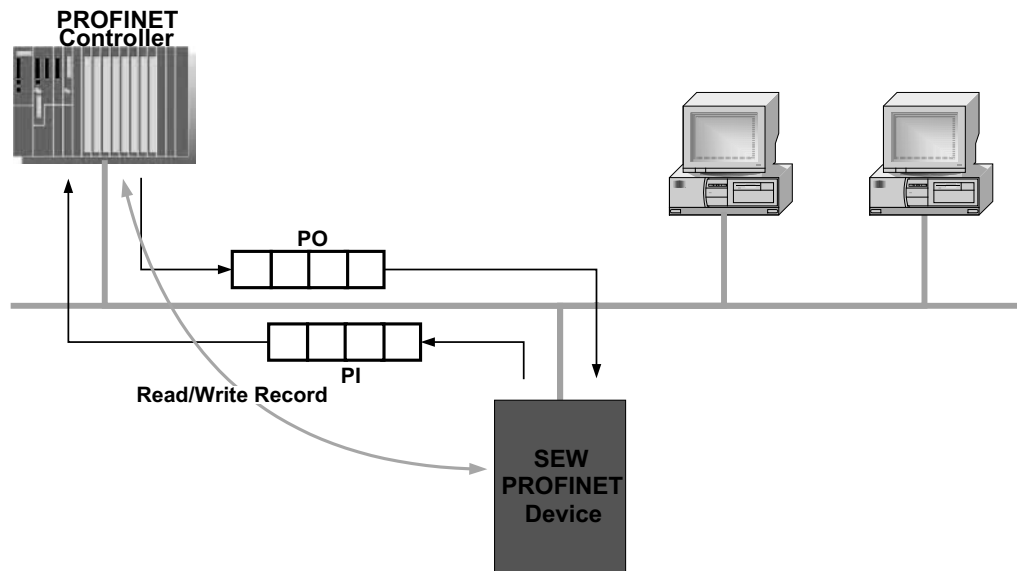

62204AXX

The user data transported via an acyclic PROFINET service is grouped in a dataset. Each dataset is clearly addressed by the following characteristics:

- API
- Slot number
- Subslot number
- Index

The structure of dataset 47 is used for the parameter exchange with SEW-EURODRIVE PROFINET units. The structure of dataset 47 is specified in the PROFIdrive profile drive technology of the PROFIBUS user organization as of V4.0 as PROFINET parameter channel. Different procedures for accessing parameter data of the SEW-EURODRIVE PROFINET unit are provided via this parameter channel.



7.1.1 Features of the SEW-EURODRIVE PROFINET devices

The SEW-EURODRIVE PROFINET units that support acyclic Read Record and Write Record services all have the same communication characteristics. The units are basically controlled via a PROFINET controller with cyclic process data. Additionally, this controller (usually a PLC) can set the parameters for the SEW-EURODRIVE PROFINET unit via Read Record and Write Record.

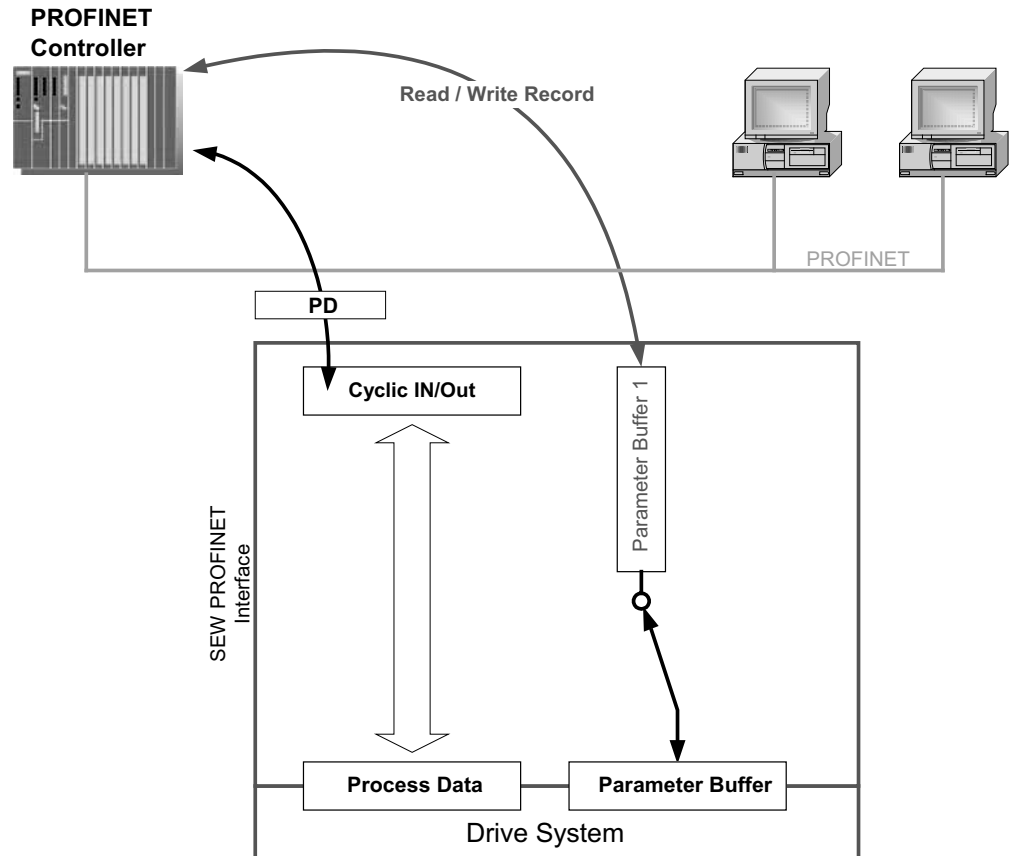

62205AXX

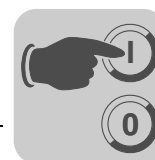

7.2 Structure of the PROFINET parameter channel

Generally, the parameterization for the drives to the PROFIdrive-Base Mode Parameter Access of profile version 4.0 is implemented via data set 47. The *Request ID* entry is used to distinguish between parameter access based on PROFIdrive profile or via SEW-MOVILINK® services. The following table shows the possible codes of the individual elements. The data set structure is the same for PROFIdrive and MOVILINK® access.



62206AXX

The following MOVILINK® services are supported:

- 8-byte MOVILINK® parameter channel with all the services supported by the inverter such as
 - READ parameter
 - WRITE parameter
 - WRITE parameter volatile
 - etc.

Field	Data type	Values
	Unsigned8	0x00 0x01 ... 0xFF
		Reserved
Request ID	Unsigned8	0x40 0x41
		SEW MOVILINK® service SEW Data Transport
Response ID	Unsigned8	<u>Response (+):</u> 0x00 0x40 0x41
		Reserviert SEW-MOVILINK®-Service (+) SEW Data Transport
		<u>Response (-):</u> 0xC0 0x41
		SEW-MOVILINK®-Service (-) SEW Data Transport
	Unsigned8	0x00 ... 0xFF
		Number of axes 0 ... 255
No. of Parameters	Unsigned8	0x01 ... 0x13
		1 ... 19 DWORDs (240 DP-V1 data bytes)
Attribute	Unsigned8	For SEW MOVILINK® (Request ID = 0x40): 0x00 0x10 0x20 0x40 0x50 0x60 0x80 0x90 0xA0 ... 0xF0
		No service READ Parameter WRITE Parameter Read Minimum Read Maximum Read Default Read Attribute Read EEPROM Reserved
		SEW data transport: 0x10 Value
No. of Elements	Unsigned8	0x00 0x01 ... 0x75
		For parameters that are not indexed Quantity 1 ... 117
Parameter Number	Unsigned16	0x0000 ... 0xFFFF
		MOVILINK® parameter index
Subindex	Unsigned16	0x0000
		SEW: always 0
Format	Unsigned8	0x43 0x44
		Double word Error
No. of Values	Unsigned8	0x00 ... 0xEA
		Quantity 0 ... 234
Error Value	Unsigned16	0x0080 + MOVILINK®-Additional Code Low For SEW MOVILINK® 16 Bit error value



7.2.1 Parameterization via PROFIdrive data set 47 – procedure

Parameters are accessed with the combination of the *WRITE RECORD* and *READ RECORD* PROFINET services. The parameterization request is transferred to the IO device using the *WRITE.req*, Then it is processed internally.

The controller now sends a *READ.req* to pick up the parameterization response. The device sends a positive response *READ.res*. The user data now contain the parameterization response of the parameterization request that was previously sent with *WRITE.req* (see the following figure). This mechanism applies to a PROFINET controller.

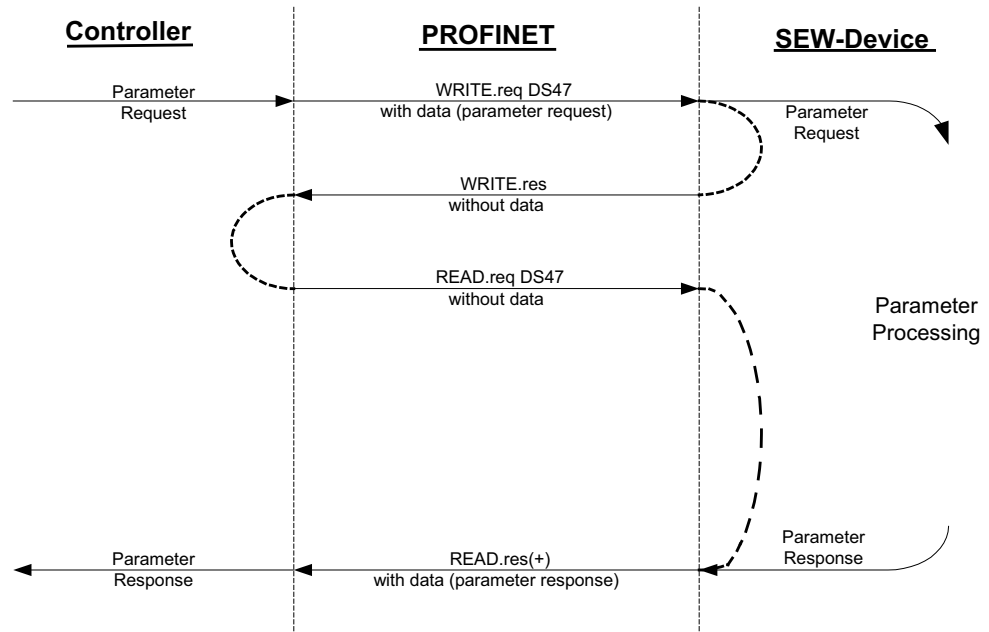

62208AXX

Figure 4: Telegram sequence for parameter access via Read/Write Record



7.2.2 Controller processing sequence

If the bus cycles are very short, the request for the parameterization response arrives before the SEW device has concluded the parameter access in the device. This means that the response data from the SEW device is not available yet. In this state, the device delays the response to the *Read Record Request*.

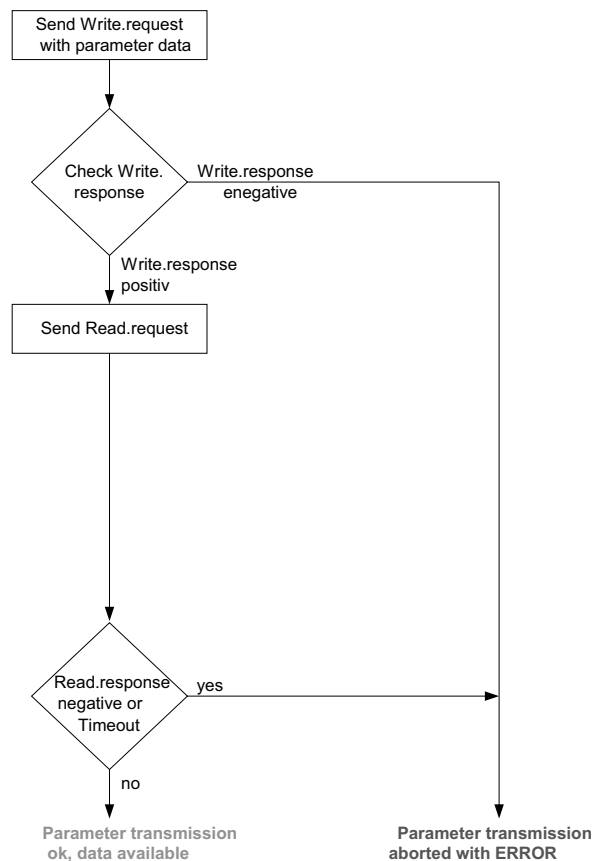

62209AEN



7.2.3 Addressing connected inverters

The structure of the DS47 data set defines an *axis* element. This element is used to reach multi-axis drives that are operated via one PROFINET interface. The *axis* element addresses one of the units connected via the PROFINET interface.

Addressing a MOVIDRIVE® B on the PROFINET

With the setting *Axis = 0*, the parameters of the MOVIDRIVE® B drive inverter are accessed. Since there are no drive units connected to the MOVIDRIVE® B, an access with *Axis > 0* is returned with an error code.

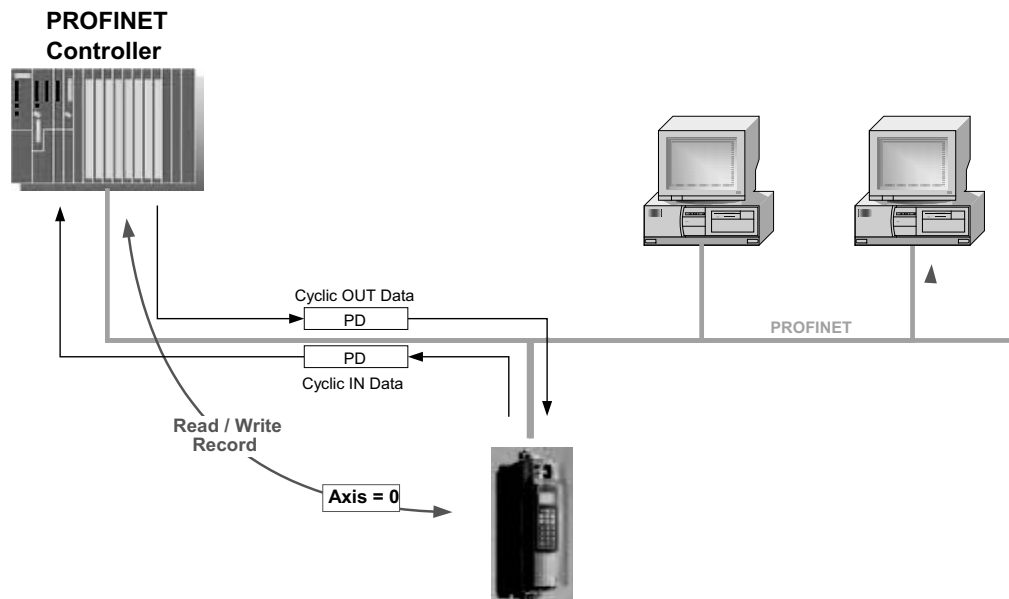

62210AXX

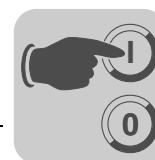

7.2.4 MOVILINK® parameter requests

The MOVILINK® parameter channel of the SEW inverter is directly mapped in the structure of data set 47. The Request ID 0x40 (SEW MOVILINK® service) is used for the exchange of MOVILINK® parameterization orders. Parameter access with MOVILINK® services usually takes place according to the structure described below. The typical telegram sequence is used for data set 47.

Request ID: 0x40 SEW MOVILINK® service

The actual service is defined by the data set element *Attribute* in the MOVILINK® parameter channel. The high nibble of the element corresponds to the MOVILINK® service code.

Example for reading a parameter via MOVILINK®

The following tables give an example of the structure of the *WRITE.request* and *READ.response* user data for reading an individual parameter via the MOVILINK® parameter channel.

Sending a parameter request

The table shows the coding of the user data for the *WRITE.request* PROFINET service. The *WRITE.request* service is used to transfer the parameterization request to the inverter. The firmware version is read.

The following table shows the WRITE request header for transferring the parameterization request.

Service	WRITE. request	Description
API	0	Fixed setting = 0
Slot_Number	0	Random (is not evaluated)
Subslot_Number	1	Fixed setting = 1
Index	47	Index of the dataset for the parameter request; constant index 47
Length	10	10 byte user data for parameter request

The following table shows the WRITE.request user data for MOVILINK® "Read parameters".

Byte	Field	Value	Description
0		0x01	Individual reference number for the parameterization request is mirrored in the parameterization response
1	Request ID	0x40	SEW MOVILINK® service
2		0x00	Axis number; 0 = Single axis
3	No. of parameters	0x01	1 parameter
4	Attributes	0x10	MOVILINK® service "READ parameter"
5	No. of elements	0x00	0 = access to direct value, no subelement
6, 7	Parameter Number	0x206C	MOVILINK® index 8300 = Firmware version
8, 9	Subindex	0x0000	Subindex 0



Query parameter response

The following table shows the coding of the READ.request user data including the PROFINET header.

Service	READ. request	Description
API	0	Fixed setting = 0
Slot_Number	0	Random (is not evaluated)
Subslot_Number	1	Fixed setting = 1
Index	47	Index of the dataset for the parameter request; constant index 47
Length	240	Maximum length of response buffer in the master

Positive MOVILINK[®] parameterization response

The table shows the READ.response user data with the positive response data of the parameterization request. The parameter value for index 8300 (firmware version) is returned as an example.

Service	READ. request	Description
API	0	Fixed setting = 0
Slot_Number	0	Random (is not evaluated)
Subslot_Number	1	Fixed setting = 1
Index	47	Index of the dataset for the parameter request; constant index 47
Length	10	Maximum length of response buffer in the master

Byte	Field	Value	Description
0		0x01	Mirrored reference number from the parameterization request
1	Response ID	0x40	Positive MOVILINK [®] response
2		0x00	Mirrored axis number; 0 = single axis
3	No. of parameters	0x01	1 parameter
4	Format	0x43	Parameter format: Double word
5	No. of values	0x01	1 value
6, 7	Value High	0x311C	Higher-order part of the parameter
8, 9	Value Low	0x7289	Lower-order part of the parameter
			Decoding: 0x 311C 7289 = 823947913 dec >> firmware version 823 947 9.13



Example for writing a parameter via MOVILINK®

The following tables show the sequence of the *WRITE* and *READ* services for volatile writing of the value 12345 to IPOS^{plus}® variable H0 (parameter index 11000) as an example. The MOVILINK® service *WRITE Parameter volatile* is used for this purpose.

Send "WRITE parameter volatile" request

Service	WRITE.request	Description
API	0	Fixed setting = 0
Slot_Number	0	Random (is not evaluated)
Subslot_Number	1	Fixed setting = 1
Index	47	Index of the dataset for the parameter request; constant index 47
Length	16	16-byte user data for order buffer

The following table shows the WRITE.request user data for MOVILINK® "Write Parameter volatile".

Byte	Field	Value	Description
0		0x01	Individual reference number for the parameterization request is mirrored in the parameterization response
1	Request ID	0x40	SEW MOVILINK® service
2		0x00	Axis number; 0 = single axis
3	No. of parameters	0x01	1 parameter
4	Attributes	0x30	MOVILINK® service WRITE parameter volatile
5	No. of elements	0x00	0 = access to direct value, no subelement
6, 7	Parameter Number	0x2AF8	Parameter index 11000 = "IPOS variable H0"
8, 9	Subindex	0x0000	Subindex 0
10	Format	0x43	Double word
11	No. of values	0x01	Change 1 parameter value
12, 13	Value High word	0x0000	Higher-order part of the parameter value
14, 15	Value Low word	0x0BB8	Lower-order part of the parameter value

After sending this WRITE.request, the WRITE.response is received. If there was no status conflict in processing the parameter channel, a positive WRITE.response occurs. Otherwise, the status error is located in Error_code_1.



Query parameter response

The following table shows the coding of the READ.req user data including the PROFINET header.

Service	READ. request	Description
API	0	Fixed setting = 0
Slot_Number	0	Random (is not evaluated)
Subslot_Number	1	Fixed setting = 1
Index	47	Index of the dataset for the parameter request; constant index 47
Length	240	Maximum length of response buffer in the master

Positive response to "WRITE Parameter volatile"

Service	READ. response	Description
API	0	Fixed setting = 0
Slot_Number	0	Random (is not evaluated)
Subslot_Number	1	Fixed setting = 1
Index	47	Index of the dataset for the parameter request; constant index 47
Length	4	4 byte user data in response buffer

Byte	Field	Value	Description
0		0x01	Mirrored reference number from the parameterization request
1	Response ID	0x40	Positive MOVILINK [®] response
2		0x00	Mirrored axis number; 0 = single axis
3	No. of parameters	0x01	1 parameter

Negative parameter response

The following table shows the coding of a negative response of a MOVILINK[®] service. Bit 7 is entered in the the response ID if the response is negative.

Service	WRITE. response	Description
API	0	Fixed setting = 0
Slot_Number	0	Random (is not evaluated)
Subslot_Number	1	Fixed setting = 1
Index	47	Index of the dataset for the parameter request; constant index 47
Length	8	8 byte user data in response buffer

Byte	Field	Value	Description
0		0x01	Mirrored reference number from the parameterization request
1	Response ID	0xC0	Negative MOVILINK [®] response
2		0x00	Mirrored axis number; 0 for single axis
3	No. of parameters	0x01	1 parameter
4	Format	0x44	Error
5	No. of values	0x01	1 Error code
6, 7	Error value	0x0811	MOVILINK [®] return code e.g. error class 0x08, Add. code 0x11 (see section "MOVILINK [®] parameterization return codes for PROFINET" on page 81)



**MOVILINK®
return codes of
PROFINET
parameterization**

The following table shows the return codes that are returned by the SEW PROFINET interface module in case of an error in the PROFINET parameter access.

MOVILINK® return code (hex)	Description
0x0810	Invalid index, parameter index does not exist in the unit
0x0811	Function/parameter not implemented
0x0812	Read access only
0x0813	Parameter lock activated
0x0814	Factory setting is active
0x0815	Value for parameter too large
0x0816	Value for parameter too small
0x0817	Required option card not installed
0x0818	Error in system software
0x0819	Parameter access only via RS-485 process interface
0x081A	Parameter access only via RS-485 diagnostics interface
0x081B	Parameter is access-protected
0x081C	Controller inhibit is required
0x081D	Invalid value for parameter
0x081E	Factory setting was activated
0x081F	Parameter was not saved in EEPROM
0x0820	Parameter cannot be changed with output stage enabled/reserved
0x0821	Reserved
0x0822	Reserved
0x0823	Parameter may only be changed at IPOS program stop
0x0824	Parameter may only be changed when auto setup is deactivated
0x0505	Incorrect coding of management and reserved byte
0x0602	Communication error between inverter system and fieldbus interface
0x0502	Timeout of secondary connection (e.g. during reset or with Sys-Fault)
0x0608	Incorrect coding of the format field



7.2.5 PROFIdrive parameter requests

The PROFIdrive parameter channel of SEW inverters is directly mapped in the structure of data set 47. Parameter access with PROFIdrive services usually takes place according to the structure described below. The typical telegram sequence is used for data set 47. PROFIdrive only defines the two request IDs

Request ID: 0x01request parameter (PROFIdrive)

Request ID: 0x02change parameter (PROFIdrive)

This means there is restricted data access in comparison with the MOVILINK[®] services.

INFORMATION



The request ID *0x02 Change Parameter (PROFIdrive)* results in remanent write access to the selected parameter. Consequently, the internal flash/EEPROM of the inverter is written with each write access. Use the MOVILINK[®] service "WRITE Parameter volatile" if parameters must be written cyclically at short intervals. With this service, you only alter the parameter values in the RAM of the inverter.

Reading a parameter via PROFIdrive – example

The following tables show an example of the structure of the WRITE.request and READ.res user data for reading an individual parameter via the MOVILINK[®] parameter channel.

Sending a parameter request

The table shows the coding of the user data for the WRITE.req service specifying the PROFINET header. The WRITE.req service is used to transfer the parameterization request to the inverter.

Service:	WRITE.request	Description
Slot_Number	0	Random, (is not evaluated)
Index	47	Index of the data set; constant index 47
Length	10	10 byte user data for parameter request

Byte	Field	Value	Description
0		0x01	Individual reference number for the parameterization request is mirrored in the parameterization response
1	Request ID	0x01	Request parameter (PROFIdrive)
2		0x00	Axis number; 0 = single axis
3	No. of parameters	0x01	1 parameter
4	Attributes	0x10	Access to parameter value
5	No. of elements	0x00	0 = access to direct value, no subelement
6, 7	Parameter Number	0x206C	MOVILINK [®] index 8300 = Firmware version
8, 9	Subindex	0x0000	Subindex 0

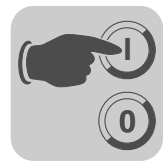

Query parameter response

The following table shows the coding of the READ.req USER DATA including the PN header.

Service:	READ.request	Description
Slot_Number	0	Random, (is not evaluated)
Index	47	Index of the data set; constant index 47
Length	240	Maximum length of response buffer in the PN controller

Positive PROFIdrive parameterization response

The table shows the READ.res user data with the positive response data of the parameterization request. The parameter value for index 8300 (firmware version) is returned as an example.

Service:	READ.request	Description
Slot_Number	0	Random, (is not evaluated)
Index	47	Index of the data set; constant index 47
Length	10	10 byte user data in response buffer

Byte	Field	Value	Description
0		0x01	Mirrored reference number from the parameterization request
1	Response ID	0x01	Positive response for "Request Parameter"
2		0x00	Mirrored axis number; 0 = single axis
3	No. of parameters	0x01	1 parameter
4	Format	0x43	Parameter format: Double word
5	No. of values	0x01	1 value
6, 7	Value Hi	0x311C	Higher-order part of the parameter
8, 9	Value Lo	0x7289	Lower-order part of the parameter
			Decoding: 0x 311C 7289 = 823947913 dec >> firmware version 823 947 9.13



Example for writing a parameter via PROFIdrive

The following tables show an example of the structure of the *WRITE* and *READ* services for the **remanent** writing of the internal setpoint n11 (see section "Example for writing a parameter via MOVILINK[®]", page 79). The *Change parameter* PROFIdrive service is used for this purpose.

Send "WRITE parameter" request

The following table shows the PROFINET header of the WRITE request with parameterization request.

Service:	WRITE.request	Description
Slot_Number	0	Random, (is not evaluated)
Index	47	Index of the data set; constant index 47
Length	16	16-byte user data for order buffer

The following table shows the WRITE.req user data for the "Change Parameter" PROFIdrive service .

Byte	Field	Value	Description
0		0x01	Individual reference number for the parameterization request is mirrored in the parameterization response
1	Request ID	0x02	Change parameter (PROFIdrive)
2		0x01	Axis number; 0 = single axis
3	No. of parameters	0x01	1 parameter
4	Attributes	0x10	Access to parameter value
5	No. of elements	0x00	0 = access to direct value, no subelement
6, 7	Parameter Number	0x7129	Parameter index 8489 = P160 n11
8, 9	Subindex	0x0000	Subindex 0
10	Format	0x43	Double word
11	No. of values	0x01	Change 1 parameter value
12, 13	Value HiWord	0x0000	Higher-order part of the parameter value
14, 15	Value LoWord	0x0BB8	Lower-order part of the parameter value

After sending this WRITE.request, the WRITE.response is received. If there was no status conflict in processing the parameter channel, a positive WRITE.response occurs. Otherwise, the status error is located in Error_code_1.

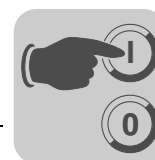

Query parameter response

The following table shows the coding of the WRITE.req user data including the PROFINET header.

Field	Value	Description
Function_Num		READ.req
Slot_Number	X	Slot_Number not used
Index	47	Index of the data set
Length	240	Maximum length of response buffer in the PN controller

Positive response to "WRITE parameter"

The following table shows the PROFINET header of the positive READ.response with parameterization response.

Service:	READ.response	Description
Slot_Number	0	Random, (is not evaluated)
Index	47	Index of the data set; constant index 47
Length	4	4 byte user data in response buffer

The following table shows the positive response for the "Change Parameter" PROFIdrive service .

Byte	Field	Value	Description
0		0x01	Mirrored reference number from the parameterization request
1	Response ID	0x02	Positive PROFIdrive response
2		0x01	Mirrored axis number; 0 = Single axis
3	No. of parameters	0x01	1 parameter

Negative parameter response

The following table shows the coding of a negative response of a PROFIdrive service. Bit 7 is entered in the response ID if the response is negative.

Service:	READ.response	Description
Slot_Number	0	Random, (is not evaluated)
Index	47	Index of the data set; constant index 47
Length	8	8 byte user data in response buffer

Byte	Field	Value	Description
0	Response reference	0x01	Mirrored reference number from the parameterization request
1	Response ID	0x810x82	Negative response for "Request parameter," negative response for "Change Parameter"
2		0x00	Mirrored axis number; 0 = single axis
3	No. of parameters	0x01	1 parameter
4	Format	0x44	Error
5	No. of values	0x01	1 Error code
6, 7	Error value	0x0811	MOVILINK [®] return code e.g. error class 0x08, Add. code 0x11 (see section "MOVILINK [®] return codes for PROFINET", page 81)



PROFIdrive return codes for PROFINET

The following table shows the coding of the error number in the PROFIdrive parameter response according to PROFIdrive profile V3.1. This table applies if you use the PROFIdrive services "Request Parameter" or "Change Parameter".

Error no.	Meaning	Used for
0x00	Invalid parameter number.	Access to non-existent parameters
0x01	Parameter value cannot be changed	An attempt was made to change a parameter value that cannot be changed
0x02	Minimum or maximum value exceeded	An attempt was made to change a value to one that is outside of the limit values
0x03	Incorrect subindex	Access to non-existent subindex
0x04	No assignment	Access with subindex to parameter that is not indexed
0x05	Incorrect data type	An attempt was made to change a replace a value with one that does not correspond to the data type of the parameter
0x06	Setting not permitted (can only be reset)	An attempt was made to set a value to one larger than 0 where this is not permitted
0x07	Description element cannot be changed	Access to description element that cannot be changed
0x08	Reserved	(PROFIdrive Profile V2: PPO write query for IR not available)
0x09	Description does not exist	Access to description that is not accessible (parameter value exists)
0x0A	Reserved	(PROFIdrive Profile V2: incorrect access group)
0x0B	No operation priority	An attempt was made to change a parameter without change rights
0x0C	Reserved	(PROFIdrive Profile V2: incorrect password)
0x0D	Reserved	(PROFIdrive Profile V2: text cannot be read in cyclic data transfer)
0x0E	Reserved	(PROFIdrive Profile V2: name cannot be read in cyclic data transfer)
0x0F	No text assignment available	Access to text assignment that is not accessible (parameter value exists)
0x10	Reserved	(PROFIdrive Profile V2: no PPO write)
0x11	Request cannot be executed due to the operating mode	Access is currently not possible and the reason is not explained
0x12	Reserved	(PROFIdrive Profile V2: other error)
0x13	Reserved	(PROFIdrive Profile V2: data cannot be read in cyclic exchange)
0x14	Incorrect value	An attempt was made to change a value to one that is in the permitted range but is not permitted due to other long-term reasons (parameter with specified individual values)
0x15	Response is too long	The length of the current response exceeds the maximum transmittable length
0x16	Invalid parameter address	Invalid value or value that is not valid for this attribute, number of elements, parameter number, subindex or a combination of these factors.
0x17	Incorrect format	Write request: Invalid format or parameter data format that is not supported
0x18	Number of values is not consistent	Write request: Number of values of parameter data does not correspond to the number of elements in the parameter address
0x19	Axis does not exist	Access to an axis that does not exist
up to 0x64	Reserved	-
0x65..0xFF	Depends on the manufacturer	-



7.3 Read/write parameters via data set 47

7.3.1 Sample program for SIMATIC S7

The STEP 7 code stored in the GSD file shows how parameters are accessed via the STEP 7 system function modules SFB 52/53. You can copy the STEP 7 code and import/compile it as a STEP 7 source.

INFORMATION



- There is an example of a function module for SIMATIC S7 controls available for download in the Software section on the SEW website (www.sew-eurodrive.de).
- This example is a special and free service that demonstrates only the basic approach to generating a PLC program. SEW is not liable for the contents of the sample program.

7.3.2 Technical data PROFINET for MOVIDRIVE® DFE32B

GSD file for PROFINET:GSDML-V2.1-SEW-DFE-DFS-2Ports-yyyy.mm.dd.xml	
Module name for project planning:	MOVIDRIVE® DFE32B
Supported data set:	Index 47
Supported slot number:	Recommended: 0
Manufacturer code:	10A hex (SEW-EURODRIVE)
Profile ID:	0
C2 response timeout	1 s
Max. length C1 channel:	240 bytes
Max. length C2 channel:	240 bytes



7.3.3 Error codes of the PROFINET services

The following table shows possible error codes of PROFINET services that may occur in the event of an error in the communication on PROFINET telegram level. This table is relevant if you want to write your own parameterization module based on the PROFINET services because the error codes are reported directly back on the telegram level.

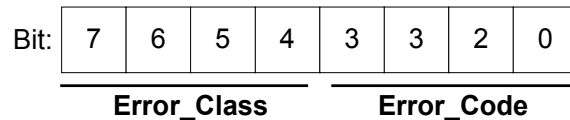

Error_Class (from PROFINET specification)	Error_Code (from PROFINET specification)	PROFINET Parameter channel
0x0 ... 0x9 hex = reserved		
0xA = application	0x0 = read error 0x2 = module failure 0x3 to 0x7 = reserved 0x8 = version conflict 0xA to 0xF = user specific	
0xB = access	0x0 = invalid index	0xB0 = No data block Index 47 (DB47); parameter requests are not supported
	0x1 = write length error 0x2 = invalid slot 0x3 = type conflict 0x4 = invalid area	
	0x5 = state conflict	0xB5 = Access to DB 47 temporarily not possible due to internal processing status
	0x6 = access denied	
	0x7 = invalid range	0xB7 = WRITE DB 47 with error in the DB 47 header
	0x8 = invalid parameter 0x9 = invalid type 0xA to 0xF = user specific	
0xC = resource	0x0 = read constraint conflict 0x1 = write constraint conflict 0x2 = resource busy 0x3 = resource unavailable 0x4..0x7 = reserved 0x8..0xF = user specific	
0xD...0xF = user specific		



8 Integrated Web Server

The DFE32B option card has a homepage for simple web diagnostics of MOVIDRIVE[®] and MOVITRAC[®]. Enter the IP address from project planning to access the homepage. You can use the web page to access information about service and diagnostics.

8.1 Software requirements

The website has been tested with Microsoft[®] Internet Explorer 5.0 and Mozilla[®] Firefox 2.0. To display dynamic elements you will need the Java 2 Runtime Environment SE, v1.5.0 or above.

If the Java 2 Runtime environment is not installed on your system, the program will connect to Java and start an automatic download, if you allow it. Should you encounter any problems, you can also download Java 2 Runtime from www.sun.com and install it locally.

8.2 Security settings

If you are using a firewall or if you have a personal firewall installed on your system, they could prevent you from accessing the Ethernet units. In this situation, you should allow outgoing TCP/IP and UDP/IP traffic.

- The applet "sewAppletsMoviEWeb.JAppletWeb" will prompt you to accept a certificate. Click [Execute]. The certificate will be imported to the certificate list of the Java 2 Runtime environment
- Select the checkbox "Always trust content from this publisher" in order to avoid this window for future executions.



8.3 Homepage layout MOVIDRIVE® MDX61B with DFE32B option

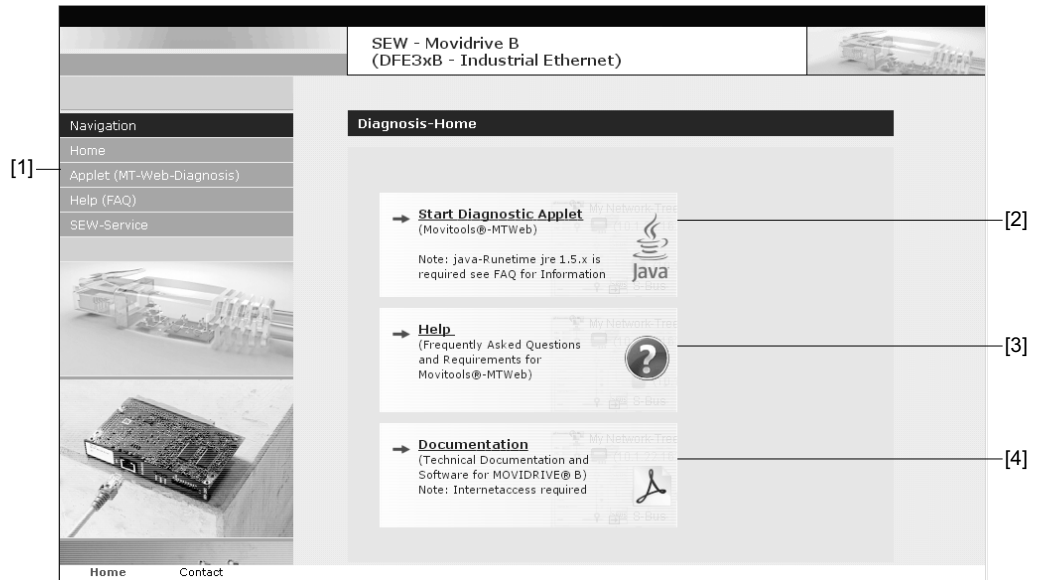

62223AXX

[1] Navigation bar	
[2] Main window (Home)	Button for starting the diagnostics applet
[3] Main window (Home)	Button for displaying website help
[4] Main window (Home)	Link to the MOVIDRIVE® B documentation page (Internet access required)



8.4 Structure of the diagnostics applet

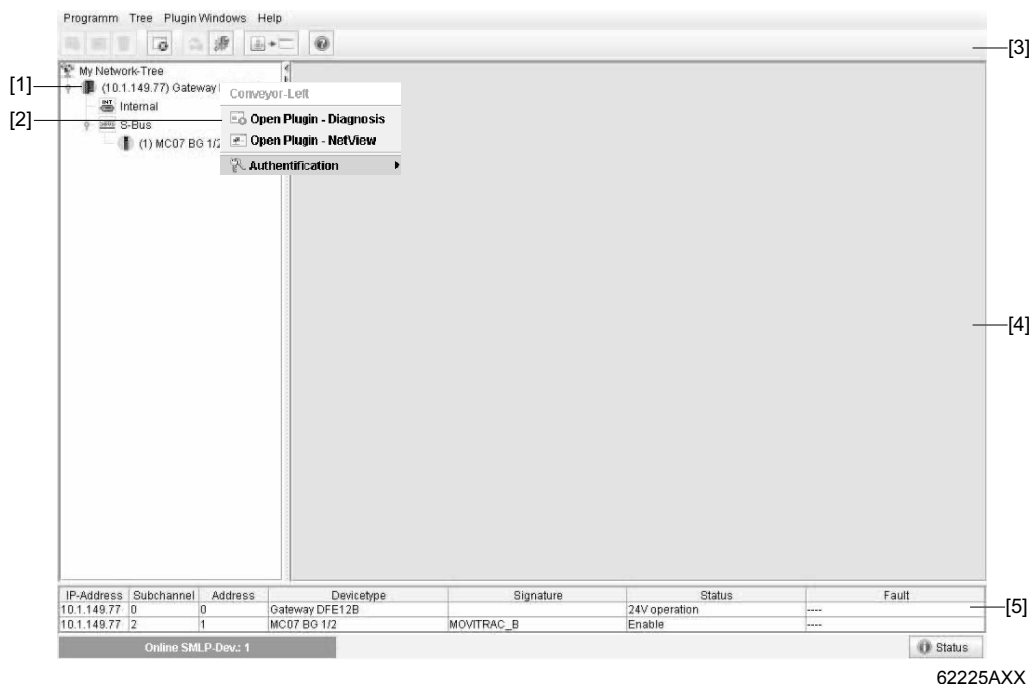

62225AXX

<p>[1] Tree view/Overview</p>	<p>The tree displays the MOVIDRIVE® B Ethernet unit in the network node "My Network Tree". Individual subsystems of the corresponding unit versions are displayed below that; they may contain additional units.</p>
<p>[2] Popup menu when you right-click on a unit in the tree</p>	<p>You can navigate to the plug-ins of an individual unit by right-clicking a unit in the tree. A popup window appears, which leads you to that unit's plug-ins. You can also adjust the access settings for a MOVIDRIVE® B (see section "Access protection"). To detect new units and have them displayed in the tree, right-click on the network node and select "Scan".</p>
<p>[3] Toolbar (Quick selection using buttons)</p>	 <p>[a] Rescan unit tree and display it in the tree [b] Open plug-in for selected unit in unit tree [c] Overview plug-in for selected unit in unit tree, see section "Plug-in window (Overview)" [d] Close the selected plug-in [e] Settings for Ethernet communication and scanner [f] Change to window mode or applet mode [g] Display information dialog box</p>
<p>[4] Plug-in window</p>	<p>See section "Plug-in window"</p>
<p>[5] Status table and unit status</p>	<p>The table is visible by default. It lists all units and subunits found during a scan. Since the status table sends cyclical parameter requests to the unit, you can also close the table using the status button (bottom right).</p>



Plug-in window

[1] Movidrive Plug-in

[2] Overview | IP-Settings | Busmonitor | Display Values

[3] Signature: MDxPROFINET Edit

Unit type: MDX61B0005-5A3

Operating Time: 813 h 45 min

Firmware Version: 824 854 0.17

Firmware Revision: 912

Status

Inverter status: Enabled

Parameterset: Parameter set 1

Operating status: Enable

Fault text: F0 - No fault

Status

62226AXX

[1] Tab for opened plug-ins	If you have opened multiple plug-ins (e.g. plug-ins of various units), they are listed in the tab.
[2] Tab within the plug-in (shows parameter displays being implemented)	If the selected unit has several display columns, the tab will display those columns.
[3] Main window with display values and figures	The main window gives a visualization of the parameters.



Example: bus monitor plug-in for MOVIDRIVE®

This plug-in is used to display the process data between the controller and the MOVIDRIVE® B as well as to diagnose the process data assignment.

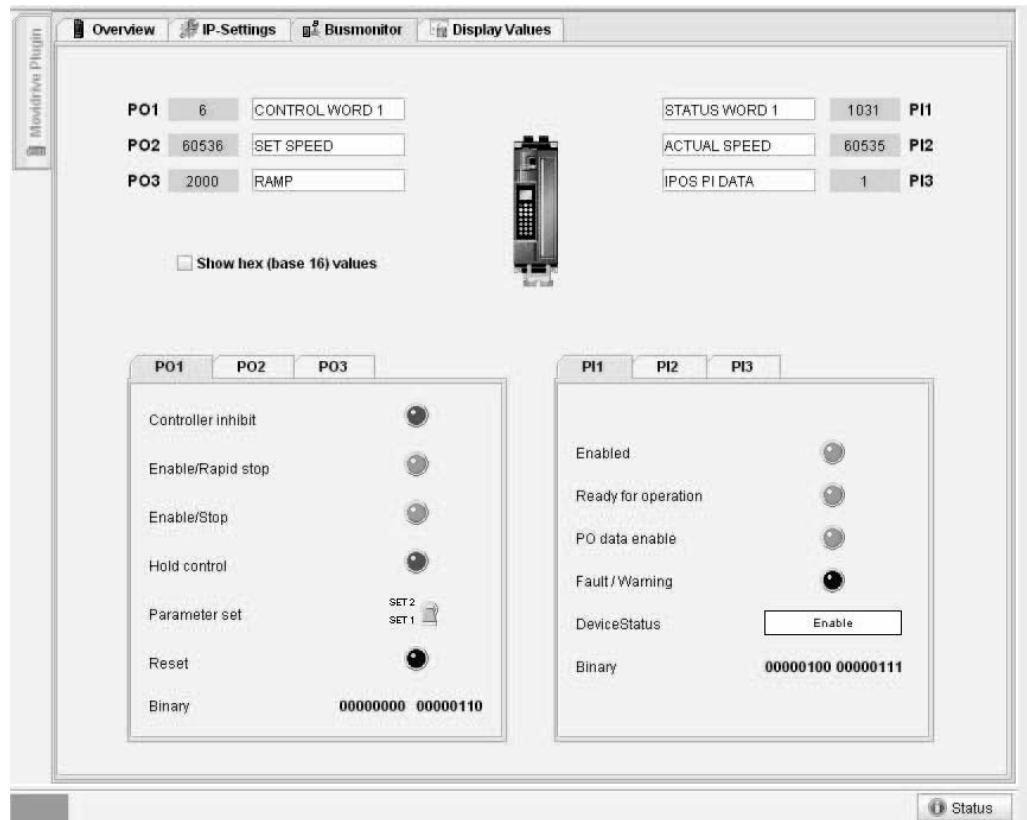

62229AXX



Integrated Web Server Structure of the diagnostics applet

Example: Bus monitor plug-in for MOVITRAC®

This plug-in is used to display the process data between the control and the MOVITRAC® B and also for diagnosing the process data assignment.

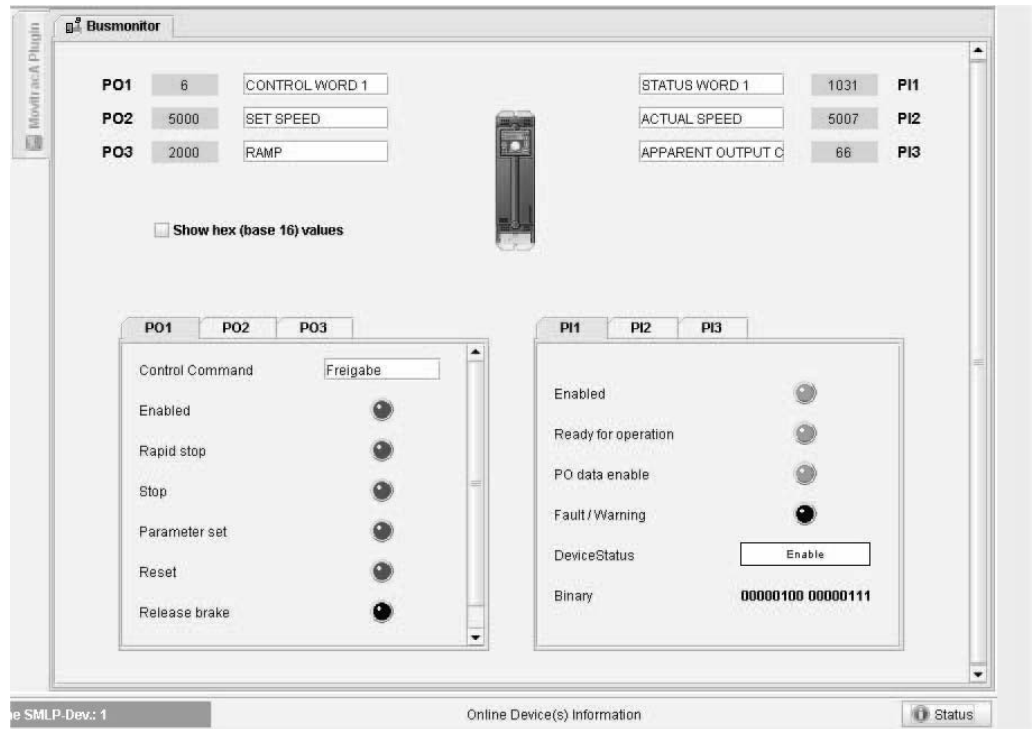

62230AXX



8.5 Access protection

Access to the drive parameters and diagnostics information can be protected by a password. Access protection is deactivated by default. You can activate the access protection function by assigning a password [2]. To deactivate the function again, delete the password (blank password).

If access protection is activated, a login dialog [1] will appear to request the saved password.

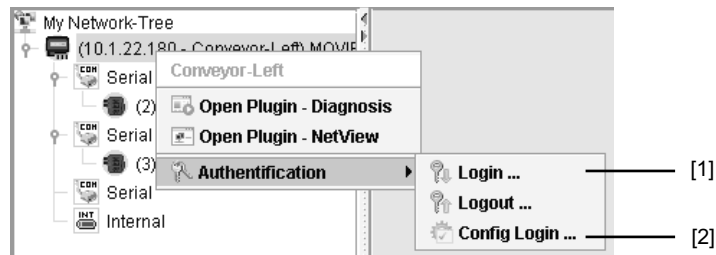

61662AXX

[1] Login



[2] Config Login



Under "User" in the login dialog, you can select "Observer" or "Maintenance".

- Observer
 - The drive unit parameters can be read with MOVITOOLS® MotionStudio but cannot be changed.
 - The current parameter settings can be uploaded from the unit to the PC (parameter set upload).
 - It is not possible to download a parameter set or an IPOSplus® program.
 - Diagnostics via MOVITOOLS® MotionStudio is possible, the scope settings, however, cannot be changed.

- Maintenance
 - MOVITOOLS® MotionStudio can be operated without any limitations.



9 MOVITOOLS® MotionStudio – Operation

9.1 About MOVITOOLS® MotionStudio

9.1.1 Tasks

The software package enables you to perform the following tasks with consistency:

- Establishing communication with units
- Executing functions with the units

9.1.2 Establishing communication with other units

The SEW Communication Server is integrated into the MOVITOOLS® MotionStudio software package for establishing communication with the units.

The SEW Communication Server allows you to create **communication channels**. Once the channels are established, the units communicate via these communication channels using their communication options. You can operate up to four communication channels at the same time.

MOVITOOLS® MotionStudio supports the following types of communication channels:

- Serial (RS-485) via interface adapters
- System bus (SBus) via interface adapters
- Ethernet
- EtherCAT
- Fieldbus (PROFIBUS DP/DP-V1)
- Tool Calling Interface

The available channels can vary depending on the units and its communication options.

9.1.3 Executing functions with the units

The software package offers uniformity in executing the following functions:

- Parameterization (e. g. in the parameter tree of the unit)
- Startup
- Visualization and diagnostics
- Programming

The following basic components are integrated into the MOVITOOLS® MotionStudio software package, allowing you to use the units to execute functions:

- MotionStudio
- MOVITOOLS®

All functions communicate using **tools**. MOVITOOLS® MotionStudio provides the right tools for every unit type.



9.2 First steps

9.3 Starting the software and creating the project

Proceed as follows to start MOVITOOLS® MotionStudio and create a project:

1. Start the MOVITOOLS® MotionStudio from the Windows start menu via:
[Start] / [Program Files] / [SEW] / [MOVITOOLS MotionStudio] / [MOVITOOLS MotionStudio]
2. Create a project with a name and directory.

9.4 Establishing communication and scanning the network

Proceed as follows to establish a communication with MOVITOOLS® MotionStudio and scan your network:

1. Set up a communication channel to communicate with your units.
For detailed information on how to configure a communication channel, see the section regarding the relevant communication type.
2. Scan your network (unit scan). Press the [Start network scan] button [1] in the toolbar.



[1]

64334AXX



9.5 Configuring units

Proceed as follows to configure a unit:

1. Mark the unit (usually the power section [1]) in the network view.
2. Right-click to open the context menu and display the tools for configuring the unit.

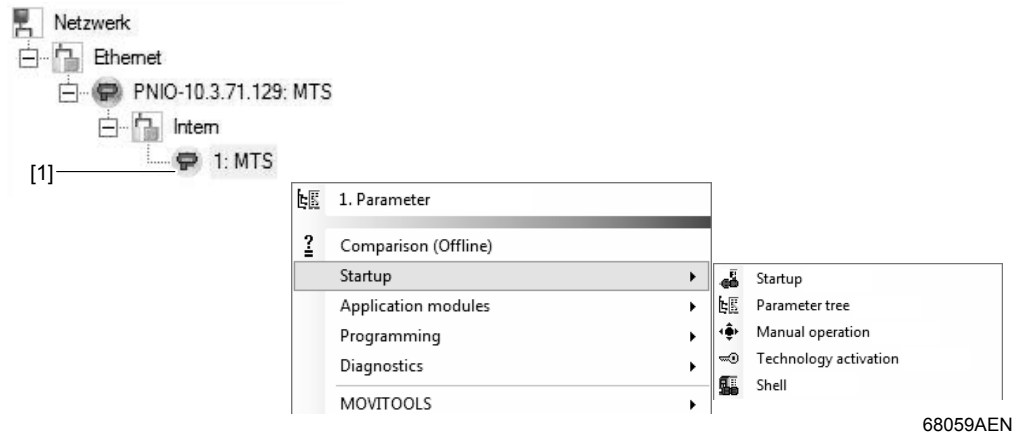

68059AEN

The example shows the context menu with the tools for MOVIDRIVE®. The communication mode is set to "online" and the unit is scanned in the network view.

3. Select a tool (e.g. "Parameter tree") to configure the unit.

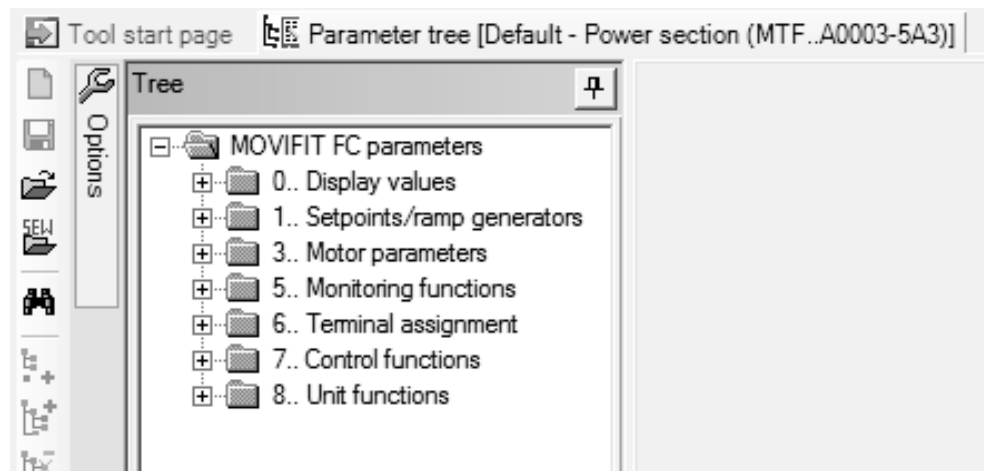

68060AEN



9.6 Connection mode

9.6.1 Overview

MOVITOOLS® MotionStudio differentiates between "online" and "offline" communication mode. You can select the communication mode yourself. Depending on the selected communication mode, you can choose offline or online tools specific to your unit.

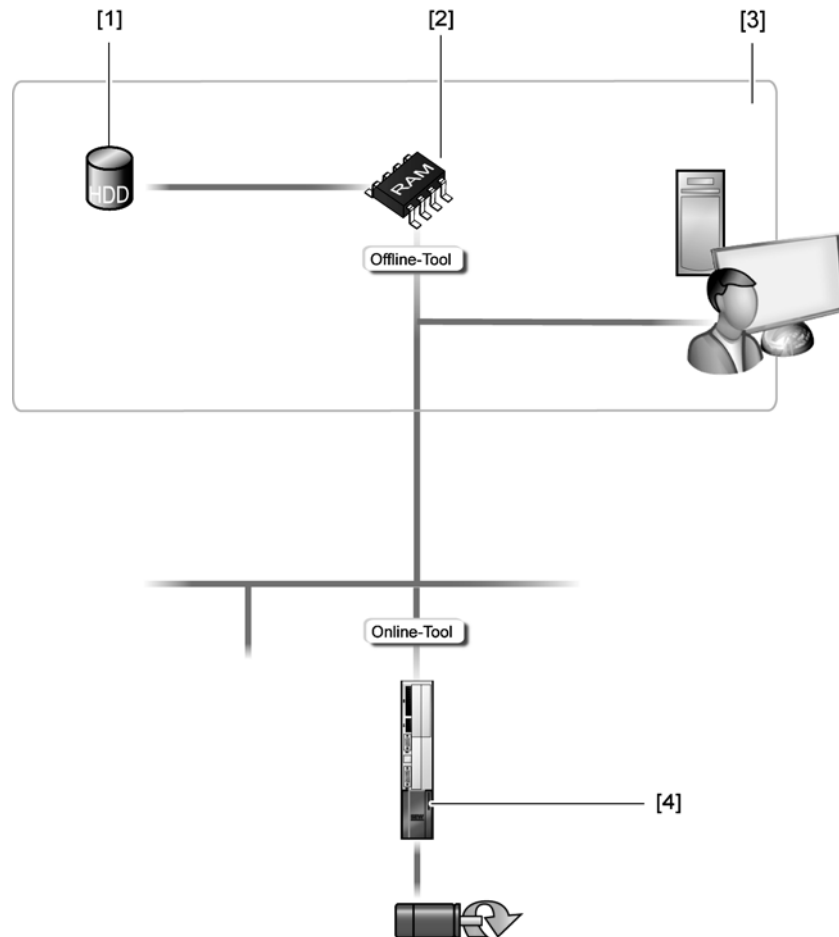

12187AXX

The following figure illustrates the two types of tools:

- [1] Hard drive of the engineering PC
- [2] RAM of the engineering PC
- [3] Engineering PC
- [4] Unit

Tools	Description
Offline tools	<p>Changes made using offline tools affect "ONLY" the RAM [2].</p> <ul style="list-style-type: none"> • Save your project so that the changes can be stored on the hard disk [1] of your engineering PC [3]. • Perform the "Download (PC->unit)" function if you want to transfer the changes to your unit [4] as well.
Online tools	<p>Changes made using online tools affect "ONLY" the unit [4].</p> <ul style="list-style-type: none"> • Perform the "Upload (unit->PC)" function if you want to transfer the changes to your RAM. • Save your project so that the changes can be stored on the hard disk [1] of your engineering PC [3].



INFORMATION



- The "online" communication mode is **NOT** a response message which informs you that you are currently connected to the unit or that your unit is ready for communication. Should you require this feedback, observe section "Setting the cyclical accessibility test" in the online help (or the manual) of MOVITOOLS® MotionStudio.
- Project management commands (such as "download" and "upload"), the online unit status, and the "unit scan" work independent of the set communication mode.
- MOVITOOLS® MotionStudio starts up in the communication mode that you set before you closed down.

9.6.2 Setting the connection mode (online or offline)

Proceed as follows to set the connection mode:

1. Select the connection mode:
 - "Switch to online mode" [1] for functions (online tools) that should directly influence the unit.
 - "Switch to offline mode" [2] for functions (offline tools) that should influence your project.

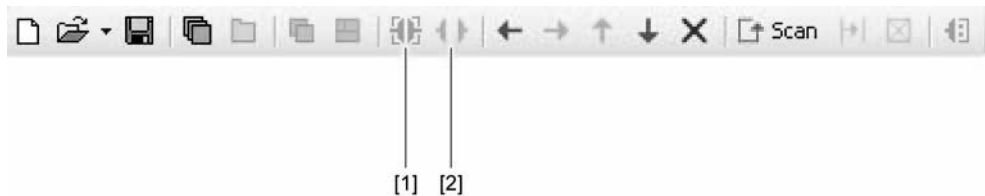

64337AXX

- [1] "Switch to online mode" icon
 [2] "Switch to offline mode" icon

2. Select the unit node.
3. Right-click to open the context menu and display the tools for configuring the unit.



9.7 Serial (RS-485) communication via interface adapter

9.7.1 Engineering via interface adapters (serial)

As your unit supports "Serial" communication, you can use a suitable interface adapter for engineering.

The interface adapter is additional hardware that you can obtain from SEW-EURODRIVE. You can use it to connect your engineering PC with the respective communication option of the unit.

The following table shows you the different types of interface adapters available, and for which units they are suitable.

Type of interface adapter (option)	Order no.	Scope of delivery	Units
USB11A (USB to RS-485)	08248311	2 connection cables: <ul style="list-style-type: none"> TAE connection cable with 2 RJ10 plugs USB connection cable with USB-A plug and USB-B plug 	<ul style="list-style-type: none"> MOVIDRIVE® B MOVITRAC® 07A MOVITRAC® B MOVIFIT® MC/FC/SC MOVIGEAR® UFx11A fieldbus gateways DFx fieldbus gateways DHx MOVI-PLC® controller MFx/MQx fieldbus interfaces for MOVIMOT®
UWS21B (RS-232 to RS-485)	18204562	2 connection cables: <ul style="list-style-type: none"> TAE connection cable with 2 RJ10 plugs Connection cable with 9-pin D-sub plug 	
UWS11A (RS-232 to RS-485) for mounting rail	822689X	Without	

As the majority of PCs come equipped with USB interfaces instead of RS-232 interfaces, the following section only focuses on the USB11A interface.

9.7.2 Taking the USB11A interface adapter into operation

Overview

The USB11A interface adapter uses a COM redirector. This assigns the first free COM port to the interface adapter.

The following section describes how to connect the USB11A interface adapter and, if required, install the respective drivers.



Connecting the USB11A interface adapter

The following figure shows how the USB11A interface adapter [2] is connected with the unit [4] and with the PC [1] via the diagnostic socket [3].

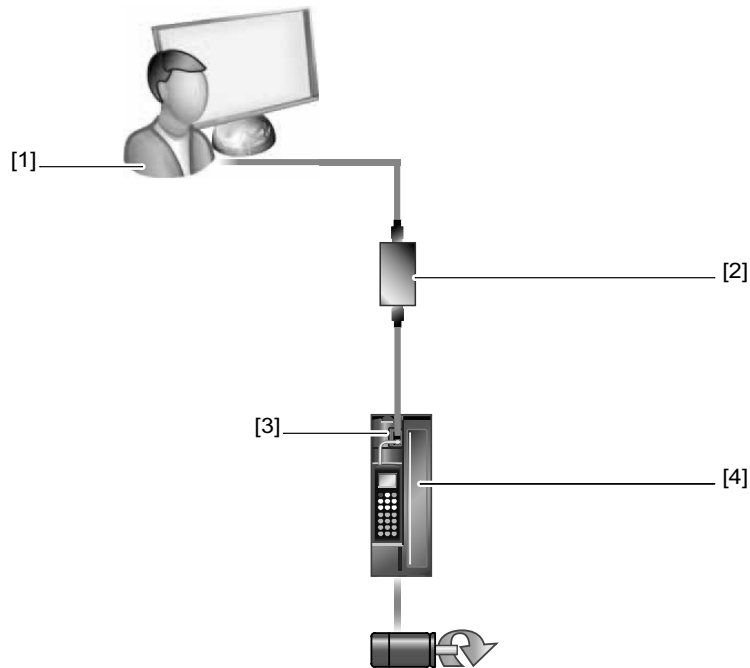

68061AXX

- [1] PC
- [2] USB11A with two connection cables (included in the scope of delivery)
- [3] Diagnostic socket of the unit
- [4] Unit (MOVIDRIVE® in this example)

Proceed as follows to connect the USB11A interface adapter with the PC and your unit:

1. Connect the USB11A interface adapter [2] with the two connection cables provided.
2. Plug the RJ10 connector of the first connector cable into the diagnostics socket [3] of the unit [4].
3. Plug the USB-A connector of the second connection cable into a free USB port on your PC [1].
4. If you are operating the interface adapter with MOVITOOLS® MotionStudio for the first time, you will have to install the required driver.



Installing the driver

The drivers for the USB11A interface adapter are copied to your PC during the installation of MOVITOOLS® MotionStudio.

proceed as follows to install the driver for the USB11A interface adapter:

1. Make sure that you have local administrator rights on your PC.
2. Connect the USB11A interface adapter to a free USB port on your PC.
Your PC will detect the new hardware and launch the hardware wizard.

The next steps depend on the installed version of MOVITOOLS® MotionStudio:

- As of **version 5.60**, the hardware wizard automatically installs the drivers. With this, the driver installation is complete and the interface adapter is ready for operation.
 - For **version 5.50** and earlier, follow the instructions of the hardware wizard (step 3).
3. Click on [Browse] and go to the MOVITOOLS® MotionStudio installation folder.
 4. Enter the following path:
`"..\Program Files\SEW\MotionStudio\Driver\FTDI_V2_XXYY"`
 5. Click the [Next] button to install the driver and assign the first free COM port of the PC to the interface adapter.

Checking the COM port of the USB11A on the PC

Proceed as follows to check which virtual COM port has been assigned to the USB11A interface adapter on the PC:

1. Select the following item from the Windows start menu:
[Start] / [Setup] / [Control panel] / [System]
2. Open the "Hardware" tab.
3. Click [Device manager].
4. Open the "Connections (COM and LPT)" folder.

You will see which virtual COM port has been assigned to the interface adapter, e.g.: "USB Serial Port (COM3)".

INFORMATION



Change the COM port of the USB11A to prevent a conflict with another COM port.

It is possible that another device (e.g. an internal modem) uses the same COM port as the USB11A interface adapter.

- Select the COM port of USB11A in the device manager.
- In the context menu, click the [Properties] button and assign the USB11A another COM port.
- Restart your system for the changes to become effective.



9.7.3 Configuring the serial communication

You must have a serial connection between your PC and the units you want to configure. You can establish one, for example, using the USB11A interface adapter.

Proceed as follows to configure serial communication:

1. Click on "Configure communication plugs" [1] in the toolbar.

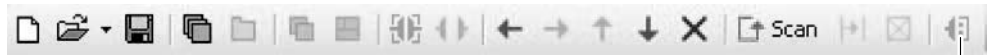

[1]

68062AXX

- [1] "Configure communication plugs" symbol

This will open the "Configure communication plugs" window.

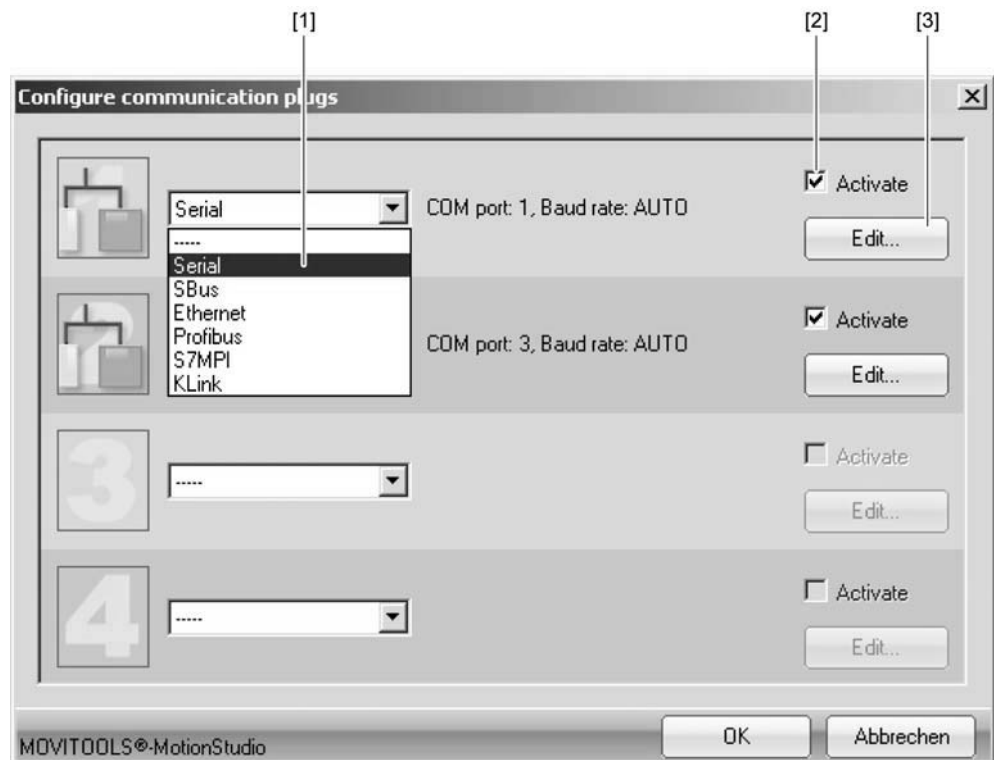

12188AEN

- [1] "Type of communication" dropdown menu
[2] "Activate" checkbox
[3] [Edit] button



- From the list [1], select "Serial" as the communication type.
In the example, "Serial" is activated as the communication type for the first communication channel [2].
- Press the [Edit] button [3] on the right side of the "Configure communication plugs" window.
This will display the settings for the "serial" communication type.



12189AEN

- It might be necessary to change the preset communication parameters on the tab pages [Basic settings] and [Advanced settings]. Refer to the detailed description of the communication parameters.



9.7.4 Communication parameters, serial (RS-485)

The following table describes the [basic setting] for the serial (RS-485) communication channel:

Communication parameters	Description	Note
COM port	Serial port connected to the interface adapter	<ul style="list-style-type: none"> If there is no value entered here, the SEW Communication Server uses the first available port. A USB interface adapter is indicated by the addition of "(USB)".
Baud rate	Transmission speed with which the connected PC communicates with the unit in the network via the communication channel.	<ul style="list-style-type: none"> Possible values: <ul style="list-style-type: none"> 9.6 kBit/s 57.6 kBit/s AUTO (default setting) Find the correct value for the connected unit in the documentation. If you set "AUTO", the units are scanned with both baud rates in succession. Set the starting value for automatic baud rate detection under [Settings] / [Options] / [Communication].

The following table describes the [extended setting] for the serial (RS-485) communication channel:

Communication parameters	Description	Note
Parameter telegrams	Telegram with a single parameter	Used for transmitting a single parameter of a unit.
Multibyte telegrams	Telegram with several parameters	Used for transmitting the complete parameter set of a unit.
Timeout	Waiting time in [ms] that the master waits for a response from the slave after it has sent a request.	<ul style="list-style-type: none"> Default setting: <ul style="list-style-type: none"> 100 ms (parameter telegram) 350 ms (multibyte telegram) Increase the value if not all units are detected during a network scan.
Retries	Number of request retries after the timeout is exceeded	Default setting: 3



9.8 Communication SBus (CAN) via interface adapter

9.8.1 Engineering via interface adapter (SBus)

Since your unit supports the "SBus" communication option, you can use a suitable interface adapter for engineering.

The interface adapter is an additional hardware component available from SEW-EURODRIVE. You can use it to connect your engineering PC with the respective communication option of the unit.

The following table shows the different types of interface adapters (options) available, and for which units they are suitable:

Interface adapter type (option)	Order no.	Scope of delivery	Units
PC-CAN interface from SEW (incl. prefabricated connection cable with integrated terminating resistor)	18210597	<ul style="list-style-type: none"> Prefabricated cable with 9-pin D-sub connector for connection to the unit, length 2 m A 120 ohm terminating resistor is fitted to one end of the prefabricated cable (between CAN_H and CAN_L). 	<ul style="list-style-type: none"> MOVIAXIS® MOVIDRIVE® B MOVITRAC® B MOVI-PLC® (<i>basic and advanced</i>)
PCAN-USB ISO from Peak	IPEH 002022	<ul style="list-style-type: none"> Without connection cable Without terminating resistor 	

To connect the PC CAN interface to the unit, you need an additional connection cable with terminating resistor. The scope of delivery of the PC CAN interface from SEW includes a prefabricated connection cable on the unit with terminating resistor. Therefore, only this PC-CAN interface is described in the following chapter.

9.8.2 Starting up the USB-CAN interface

Overview

This section describes how to connect the PC-CAN interface from SEW to the SBus interface or your units and what must be considered for this.

CAN pin assignment

The figure below shows the pin assignment of the 9-pin D-sub connector of the PC-CAN interface from SEW (view from top):

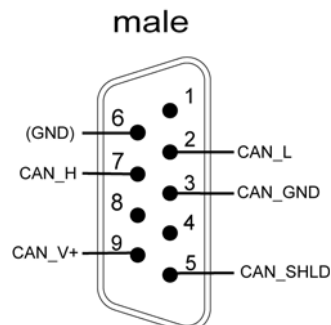

12191AXX



Connecting the USB-CAN inter- face to the unit



INFORMATION

Faulty data transmission

- Use only shielded cables suitable (approved) for CAN networks.

The figure shows how the USB-CAN interface adapter [2] from SEW is connected with the unit [4] and the PC [1] via the SBus interface [3], in this example the unit is a MOVIDRIVE®.

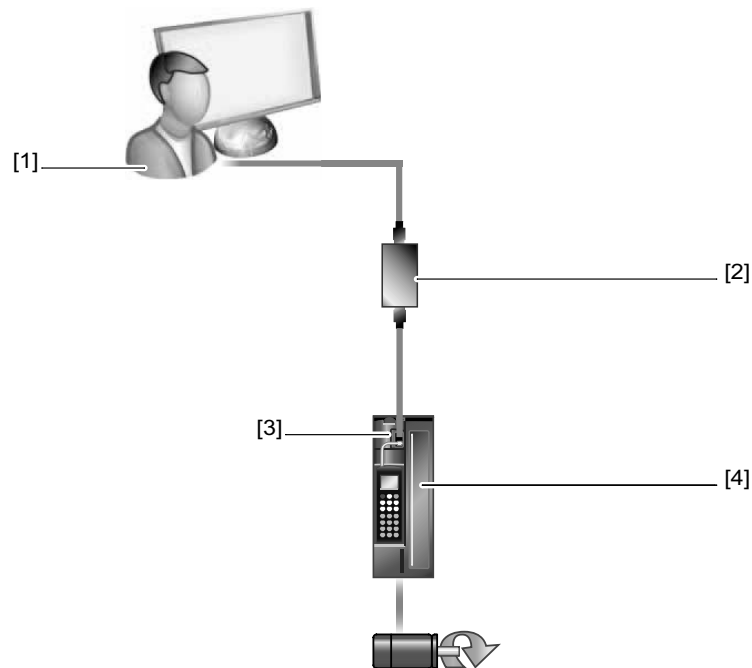

68061AXX

[1] PC

[2] USB-CAN interface with prefabricated connection cable with terminating resistor (included in the scope of delivery)

[3] SBus interface of the unit (terminal X30 on DFC11B)

[4] Unit (MOVIDRIVE® with connection option DFC11B in this example)



Proceed as follows to connect the USB-CAN interface with the PC and your unit:

1. Connect the 9-pin D-sub connector of the USB-CAN interface with the prefabricated connection cable. Make sure that the cable end with the terminating resistor leads to the USB-CAN interface.
2. Connect the second cable end (without terminating resistor) with the SBus interface [3] of the unit [4].
 - If MOVIDRIVE® is equipped with the DFC11B connection option, you can connect the D-sub plug of the prefabricated cable directly with terminal X30.
 - Without the connection option, connect the cores of the prefabricated cable to the X12 terminal of MOVIDRIVE® as follows:

Signal	Terminal on MOVIDRIVE®	CAN pin assignment (9-pin D-sub connector)	Core (Deviations are possible)
CAN_H	X12:2	PIN 7	Brown
CAN_L	X12:3	PIN 2	White
CAN_GND	X12:1	PIN 3	Shielding

3. If the unit is operated within a CAN network, connect the terminating resistor at the last unit.
 4. Plug the USB-A connector of the USB cable into a free USB interface on your PC [1].
- For detailed information about the startup of a USB-CAN interface in connection with a MOVIAXIS® unit, refer to the "MOVIAXIS® MX Multi-Axis Servo Inverter" operating instructions.

9.8.3 Configuring the communication via SBus

You need an SBus connection between your PC and the units you want to configure. You can use a USB-CAN interface for this purpose.

Proceed as follows to configure SBus communication:

1. Click on "Configure communication plugs" [1] in the toolbar.



[1]

68062AXX

[1] "Configure communication plugs" symbol



This will open the "Configure communication plugs" window.

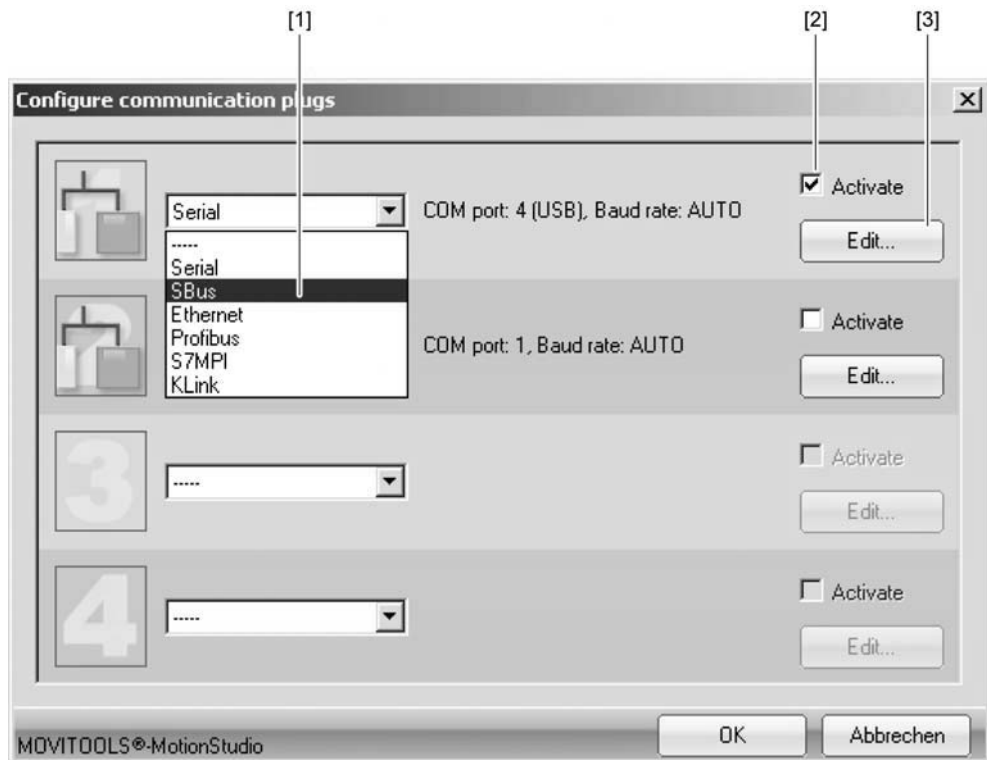

12193AEN

- [1] "Type of communication" dropdown menu
- [2] "Activate" checkbox
- [3] [Edit] button



2. From the list [1], select "SBus" as the communication type.
In the example, "SBus" is activated as the communication type for the first communication channel [2].
3. Press the [Edit] button [3] on the right side of the "Configure communication plugs" window.



12192AEN

This will display the settings for the "SBus" communication type.

4. It might be necessary to change the preset communication parameters on the tab pages [Basic settings] and [Advanced settings]. When doing so, refer to the detailed description of the communication parameters.



9.8.4 Communication parameters for SBus

The following table describes the [Basic setting] for the SBus communication channel:

Communication parameters	Description	Note
Baud rate	Transmission speed with which the connected PC communicates with the unit in the network via the communication channel.	<ul style="list-style-type: none"> Adjustable values (permitted total cable length): <ul style="list-style-type: none"> 125 kBaud (500 m) 250 kBaud (250 m) 500 kBaud (100 m) (default) 1 MBaud (25 m) All connected units must support the same baud rate.

The following table describes the [Advanced setting] for the SBus communication channel:

Communication parameters	Description	Note
Parameter telegrams	Telegram with a single parameter	Used for transmitting a single parameter of a unit.
Multibyte telegrams	Telegram with several parameters	Used for transmitting the complete parameter set of a unit.
Timeout	Waiting time in [ms] that the master waits for a response from the slave after it has sent a request.	<ul style="list-style-type: none"> Default setting: <ul style="list-style-type: none"> 100 ms (parameter telegram) 350 ms (multibyte telegram) Increase the value if not all units are detected during a network scan.
Retries	Number of request retries after the timeout is exceeded	Default setting: 3



9.9 Communication via Ethernet

9.9.1 Address Editor

Overview

The Address Editor is a freeware tool by SEW-EURODRIVE GmbH & Co KG.

It is available once the "MOVITOOLS® MotionStudio" engineering software is installed. However, it is used separately.

You can use the Address Editor to establish a communication for your units via Ethernet and to address the units.

If you use a patch cable to connect the Ethernet interface of your engineering PC to the Ethernet, the Address Editor detects all Ethernet nodes in the connected network segment (local network).

Unlike with "MOVITOOLS® MotionStudio", you will **not** have to adjust the IP address of the engineering PC to the local network.

This means the Address Editor is a useful addition to "MOVITOOLS® MotionStudio".

Proceed as follows if you have added other Ethernet nodes to an existing network:

- Start the Address Editor
- Search for Ethernet nodes

Once you have found the added Ethernet nodes, you have two options:

- Setting the detected Ethernet nodes according to the network (addressing)
- Setting the engineering PC according to the network (address)

Opening the Address Editor

You can use the Address Editor once MOVITOOLS® MotionStudio has been installed.

Do the following to start the Address Editor:

1. Close MOVITOOLS® MotionStudio.
2. Start the Address Editor from the Windows start menu via:
[Start] / [Programs] / [SEW] / MOVITOOLS MotionStudio] / [Address Editor (Address Tool)]



Searching for Ethernet nodes

You can use the Address Editor to find Ethernet nodes in a network. It can also be used for detecting new Ethernet nodes. The Address Editor also helps you to locate the Ethernet interface of detected Ethernet nodes.

Proceed as follows to search for Ethernet nodes and localize the hardware:

1. Select "Ethernet" as the interface for PC and unit. To do so, click on the corresponding option field in the lower part of the window.
2. Click [Next] to confirm your selection and proceed to the next dialog.
3. Wait for the network scan to start **automatically**. The default setting for the waiting time (scan timeout) is 3 s [2]

Note: If you no units are detected during the network scan, the wiring might be inadequate, or you have several network cards installed (activated) in your PC.

In this case, proceed as follows:

- Select the required card. To do so, click "Select network card" [3] in the toolbar.
- Start the network scan **manually**. To do so, click "Start network scan" [1] in the toolbar.

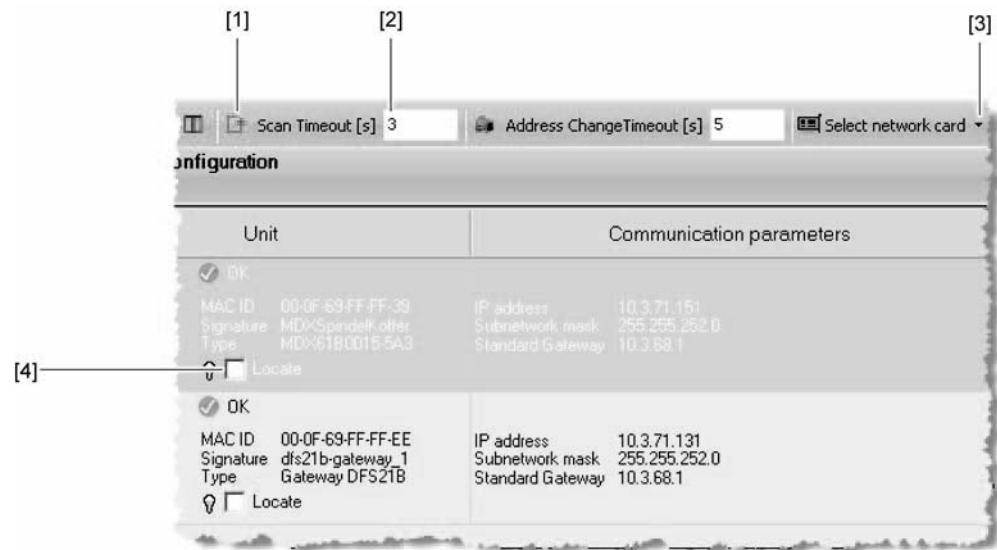

64348AXX

- [1] "Start network scan" icon
- [2] "Scan timeout" edit box
- [3] "Select network card" icon
- [4] "Localize" check box

As a result, the current addresses of all Ethernet nodes in the connected network will be displayed.

4. Mark the "Localize" check box [4] to localize an Ethernet node.

The link/act LED of the first Ethernet interface of the respective Ethernet node will flash green.



Adjusting located Ethernet nodes to the network (address)

Proceed as follows to adjust (address) the localized Ethernet nodes to the network:

1. Double-click in the "Communication parameters" area of the respective unit [1].

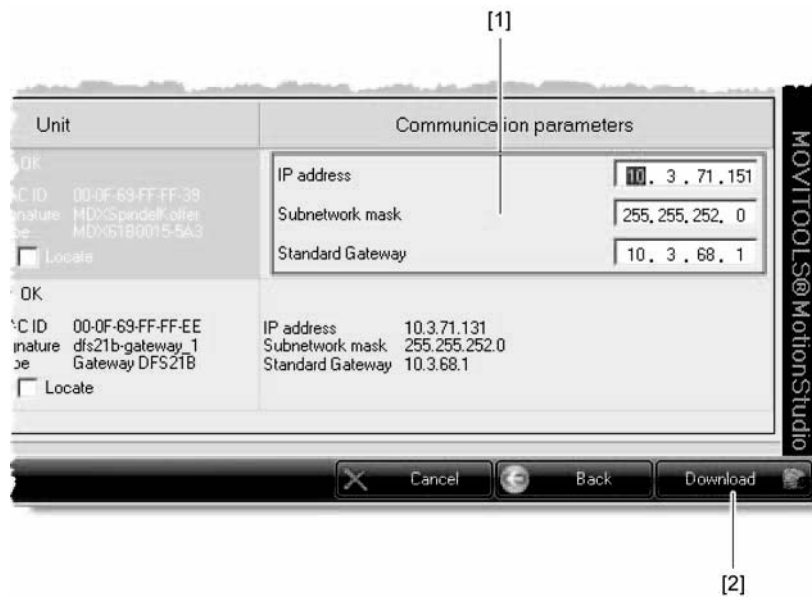

64349AXX

[1] "Communication parameters" window

[2] [Download] button

You can now change the following settings:

- IP address of the Ethernet node
- IP address of the subnet mask
- IP address of the standard gateway
- DHCP startup configuration (if supported by the unit)

2. Transmit the address changes to the Ethernet node. Click on [Download] [2].
3. Switch the unit off and on again in order to apply the changes.



Adjusting the engineering PC to the network (address)

To the following to adapt the engineering PC to the network setting (addressing):

1. Select the following item from the Windows start menu:
[Start] / [Setup] / [Network connections]
2. Select the corresponding PC interface.
3. Select "Properties" from the context menu.
4. Activate the checkbox with the entry "Internet protocol (TCP/IP)".
5. Click on the [Properties] button.
6. Activate the "Use the following IP address" checkbox.
7. For the subnetwork mask and standard gateway, enter the same IP addresses that are used for other Ethernet nodes in this local network.
8. For the engineering PC, enter an IP address that meets the following conditions:
 - In the blocks that define the **network**, the address segment for the engineering PC must correspond to the other Ethernet nodes.
 - In the blocks that define the **node**, the address segment for the engineering PC must differ from the other stations.
 - The last block must not contain the values "0", "4", "127" or "255".

NOTE: In the IP address of the subnet mask (such as 255.255.255.0), the values in the blocks have the following meaning:

 - "255", defines the address of the network where the nodes are located.
 - "0", defines the address of the actual node to distinguish it from other nodes.



9.9.2 Configuring the communication channel via Ethernet

Do the following to configure a communication channel for Ethernet:

1. Click on "Configure communication plugs" [1] in the toolbar.

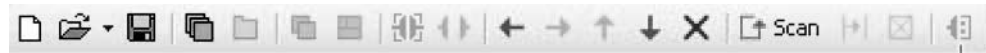

[1]
64341AXX

- [1] "Configure communication plugs" symbol

This opens the "Configure communication plugs" window.

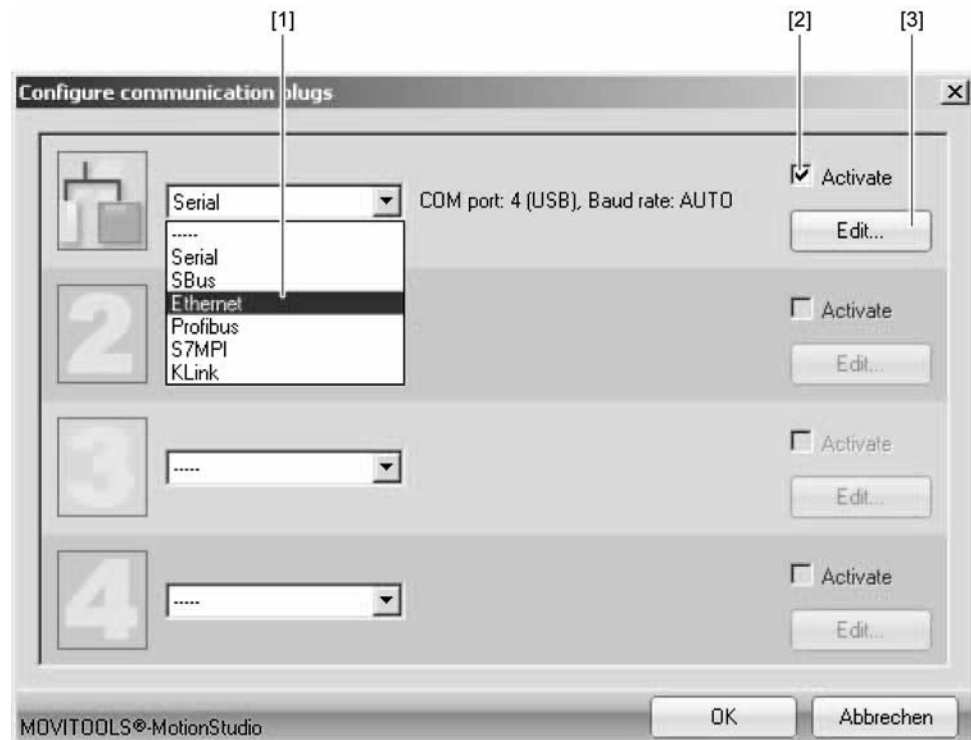

64351AEN

- [1] "Type of communication" dropdown menu
 [2] "Activate" checkbox
 [3] [Edit] button

2. From the list [1], select "Ethernet" as the communication type.

In the example, "ETHERNET" is activated as the communication type for the first communication channel [2].

3. Click [Edit] [3] in the right section of the window.

This will display the settings for the "Ethernet" communication type.

4. Set up the SMLP protocol. Select the "SMLP settings" tab.

SMLP stands for **Simple MOVILINK® Protocol**. This is the SEW-EURODRIVE unit protocol and is transmitted directly via TCP/IP.



- Set the parameters. Follow the instructions described in the section "Setting communication parameters for SMLP".

9.9.3 Setting communication parameters for SMLP

Proceed as follows to set the Ethernet communication parameters:

- Change the set communication parameters if necessary. When doing so, refer to the detailed description of the communication parameters.

NOTE: During a unit scan, the system recognizes only units that are in the same (local) network segment as the PC that is running on MOVITOOLS® MotionStudio. If you have units that are outside the local network segment, add the IP addresses of these units to the list of SMLP servers.

- Add an IP address by opening the context menu and selecting [Add IP address] [1].

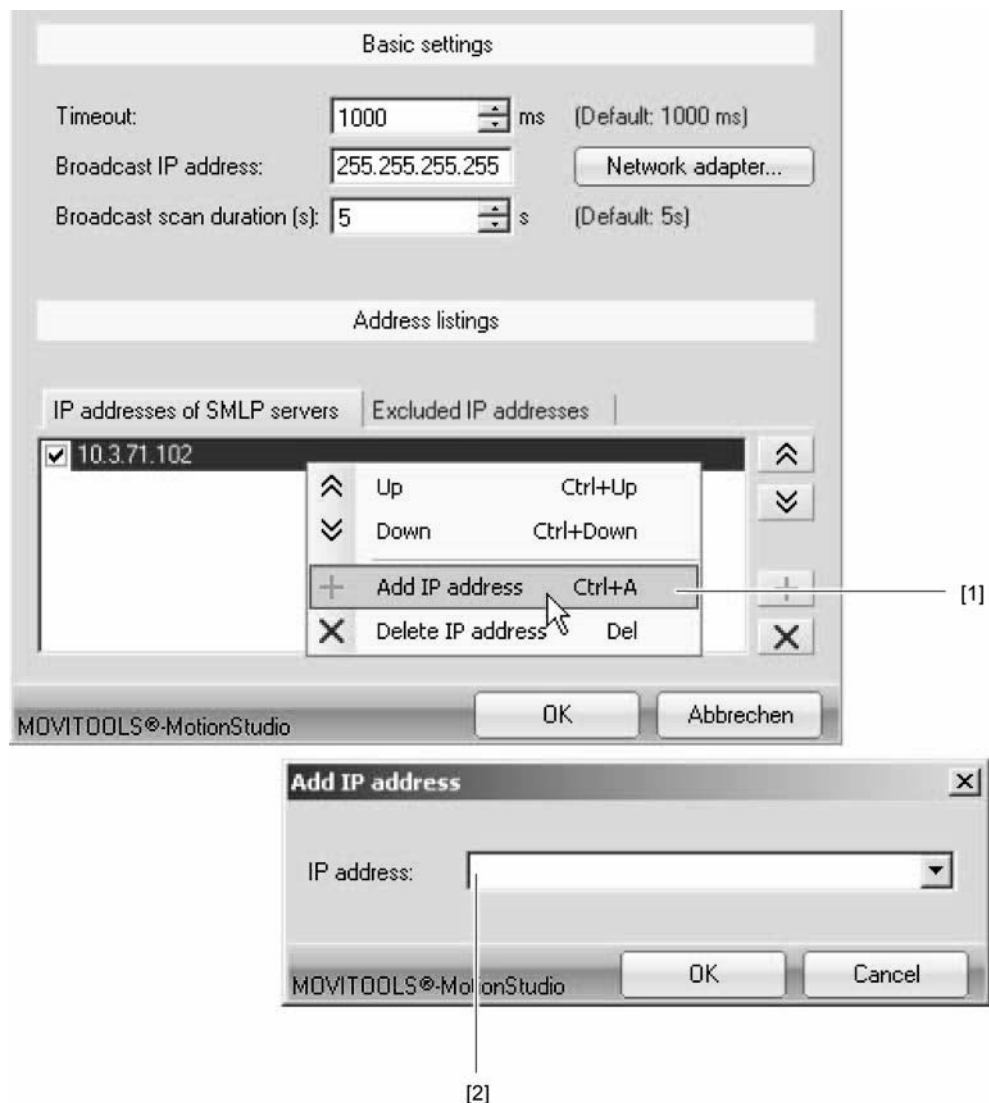

[1] [Add IP address] button

[2] "IP address" edit box

64352AEN



3. Enter the IP address in the input field [2] and click the [OK] button.

9.9.4 Communication parameters for SMLP

The following table describes the communication parameters for SMLP:

Communication parameters	Description	Note
Timeout	Waiting time in ms that the client waits for a response from the server after it has made a request.	<ul style="list-style-type: none"> • Default setting: 1000 ms • Increase the value as required if a delay in communication is causing malfunctions.
Broadcast IP address	IP address of the local network segment within which the unit scan is carried out.	In the default setting, the unit scan only detects units that are in the local network segment.
IP address of SMLP server	IP address of the SMLP server or of other units that are to be included in the unit scan but are outside the local network segment.	<ul style="list-style-type: none"> • Enter the IP address of units that are to be included in the unit scan but are outside the local network segment. • Enter the IP address of the SIMATIC S7 control, if you are operating an indirect Ethernet to PROFIBUS communication via SIMATIC S7.
Excluded IP address	IP addresses of units that should not be included in the unit scan	Enter the IP address of units that should not be included in the unit scan. This can be units that are not ready for communication (for example because they have not been started up yet)

9.9.5 Communication ports used

The following table describes the communication ports used by MOVITOOLS® MotionStudio:

Use	No. of the communication port	Description
ETH server	300	For using a PC as Ethernet gateway with the program "ETHServer.exe"
SEW communication server	301	For communication between MOVITOOLS® MotionStudio and the SEW Communication Server
Offline data server	302	For communication of MOVITOOLS® MotionStudio in offline mode
MOVIVISION® server	303	For communication with a PC with active MOVIVISION® server
MOVI-PLC® visualization	304	For communication between MOVI-PLC® and the 3D simulation of MOVITOOLS® MotionStudio
TCI server	305	For communication via TCI
EcEngineeringServer remote control (in preparation)	306	For direct communication (without master) with SEW EtherCAT slaves
EcEngineeringServer mailbox gateway (in preparation)	307	For direct communication (without master) with SEW EtherCAT slaves



9.10 Executing functions with the units

9.10.1 Unit parameterization

Units are parameterized in the parameter tree. It displays all unit parameters, grouped into folders.

You can manage the unit parameters using the context menu and the toolbar. The following steps illustrate how to read/edit unit parameters.

9.10.2 Reading or changing unit parameters

proceed as follows to read or change unit parameters:

1. Switch to the required view (project view or network view).
2. Select the connection mode:
 - Click the "Switch to online mode" button [1] if you want to read or change parameters directly on the **unit**.
 - Click the "Switch to offline mode" button [2] if you want to read or change parameters in the **project**.



[1] "Switch to online mode" icon

[2] "Switch to offline mode" icon

3. Select the unit you want to parameterize.
4. Open the context menu and select the [Parameter tree] command.
Then, the "Parameter tree" view opens on the right section of the screen.

64337AXX



- Expand the "Parameter tree" up to the node you require.

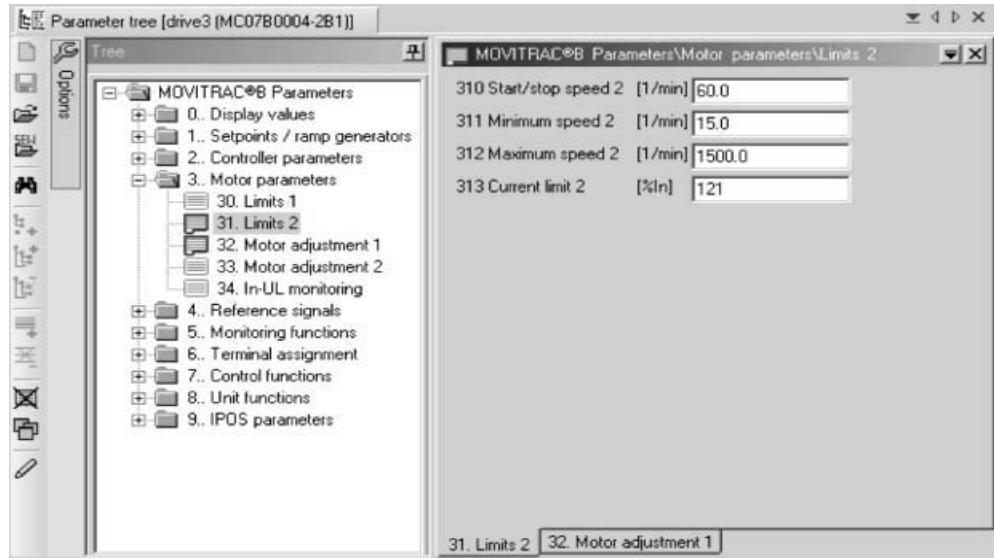

12079AEN

- Double-click to display a particular group of unit parameters.
- Press the enter key to finalize any changes you make to numerical values in the input fields.

INFORMATION



- Refer to the parameter list in the unit documentation for detailed information on the unit parameters.

9.10.3 Starting up units (online)

Do the following to start up the units (online):

- Switch to the network view.
- In the toolbar, click on "Switch to online mode" [1].



[1]

64354AXX

- "Switch to online mode" icon
- Select the unit you want to startup.
- Open the context menu and select the command [Startup] / [Startup].
The Startup wizard opens.
- Follow the instructions of the startup wizard and then load the startup data into your unit.



10 Error Diagnostics

10.1 *Diagnostics procedures*

The diagnostics procedures described in the following section demonstrate the error analysis methods for the most frequent problems:

- Inverter does not work on PROFINET IO
- Inverter cannot be controlled using the IO controller

For more information, especially regarding the inverter parameterization for various fieldbus applications, refer to the *Fieldbus Unit Profile manual* and the *MOVIDRIVE[®] parameter list*.

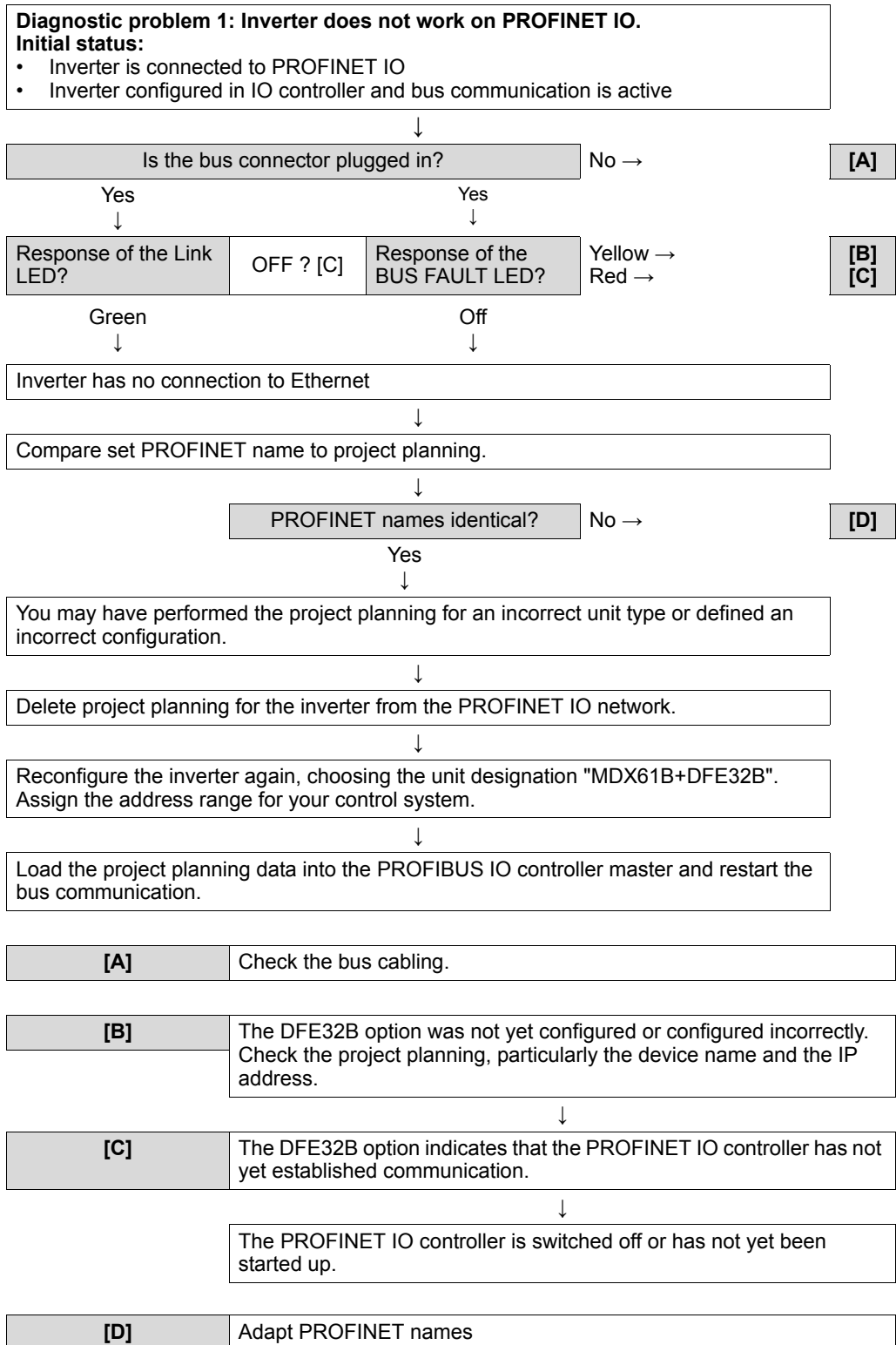



Diagnostic problem 2:

Inverter cannot be controlled via the IO controller

Initial status:

- Bus communication with inverter OK (LED BUS FAULT off)
- Inverter running with 24 V (no supply voltage)



The problem is either caused by incorrect parameterization in the inverter or a faulty control program in the PROFINET IO controller.



Use P094 ... P097 (setpoint description PO1 ... PO3) to check whether the setpoints sent by the controller are received correctly. To do so, send a setpoint other than 0 as a test in each output word.



Setpoints received?

Yes →

[A]

No



Check that the correct settings have been made for the following drive parameters:

- P100 SETPOINT SOURCE FIELD BUS
- P101 CONTROL SIGNAL SOURCE FIELD BUS
- P876 ENABLE PO DATA YES



Settings OK?

No →

[B]

Yes



The problem may be caused by your control program in the IO controller.



Check that the address used in the program is the same as the address for project planning. Note that the inverter requires consistent data and access must take place within the control program, if necessary, via special system functions (for example, SIMATIC S7, SFC 14/15).

[A]

Setpoints are transferred.
Check whether the drive inverter has been enabled at the terminals.

[B]

Correct settings.



10.2 Error list in gateway operation

Error code	Designation	Response	Cause	Measure
25	EEPROM	SBus communication stopped	Error while accessing EEPROM	Restore factory settings, perform reset and parameterize DFE again. Consult SEW service if the error reoccurs
28	Fieldbus timeout	Default: PO data = 0 Error response adjustable via P831	No communication between master and slave within the projected response monitoring.	<ul style="list-style-type: none"> • Check communications routine of the master • Extend the fieldbus timeout interval (response monitoring) in the project planning for the master or deactivate monitoring
37	Watchdog error	SBus communication stopped	Error while executing system software	Consult SEW Service.
38	Internal error	SBus communication stopped	Inverter electronics is faulty, possibly due to EMC influence	Check ground connections and shielding and correct, if necessary. Consult SEW service if this error reoccurs.
45	Error initialization	SBus communication stopped	Error after self-test during reset	Perform a reset. Consult SEW service if the error occurs again.
111	Device timeout system error	None	Check the red system error LED (H1) of the DFE. If this LED is on, one or several nodes on the SBus could not be addressed within the timeout interval. If the red system error LED (H1) flashes, the DFE itself is in an error state. In this case, error F111 was only reported to the controller via fieldbus.	Check voltage supply and SBus cabling, check SBus terminating resistors. Check the project planning if the DFE was configured with the PC. Switch DFE off and on again. If the error is still present, query the error via diagnostic interface and perform the action described in this table.

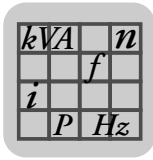

11 Technical Data

11.1 DFE32B for MOVIDRIVE® B, MOVITRAC® B and UOH11B

DFE32B option	
Part number	1821 345 6
Power consumption	P = 3 W
Voltage supply (only in gateway operation)	U = DC 24 V (-15%/+20%) I _{max} = DC 200 mA P _{max} = 3.4 W
Application protocols	<ul style="list-style-type: none"> • PROFINET IO (Ethernet frames with frame identification 8892_{hex}) to control and parameterize the inverter. • HTTP (Hypertext Transfer Protocol) for diagnostics using a Web browser. • SMLP (Simple Movilink Protocol), protocol used by MOVITOOLS®.
Port numbers used	<ul style="list-style-type: none"> • 300 (SMLP) • 80 (HTTP)
Ethernet services	<ul style="list-style-type: none"> • ARP • ICMP (ping)
ISO/OSI layer 2	Ethernet II
Baud rate	100 MBd in full duplex mode
Connection technology	RJ45
Addressing	4 byte IP address or MAC-ID (00:0F:69:xx:xx:xx)
Manufacturer ID (Vendor ID)	010A _{hex}
Tools for startup	<ul style="list-style-type: none"> • MOVITOOLS® MotionStudio version 5.40 and higher. • DBG60B keypad
Firmware status of MOVIDRIVE® MDX61B	Firmware version 824 854 0.17 or later (→ display with P076)

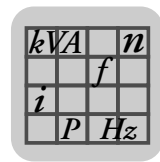

11.2 DFE32B in UOH11B gateway housing – dimension drawing

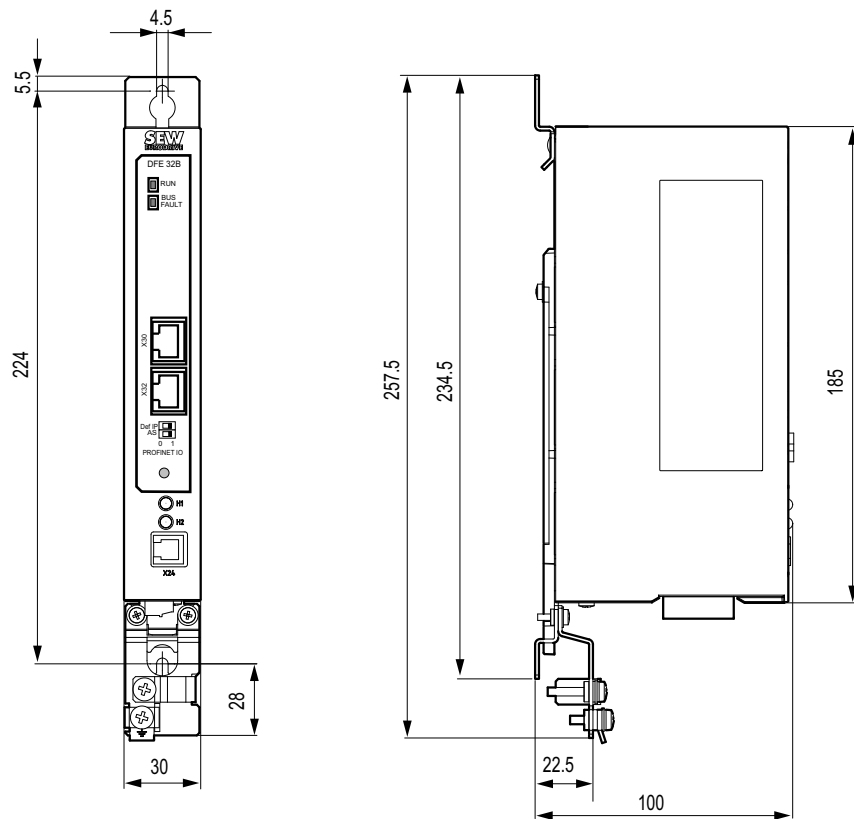

62286AXX



12 Index

- A**
- Access protection95
 - Adapters
 - Starting up the USB-CAN interface*107
 - Address Editor113
 - Addressing126
 - Assembly and Installation Notes
 - DFE32B option card in MOVIDRIVE®*
 - MDX61B*12
 - DFE32B option card in MOVITRAC® B*15
 - Assembly and installation notes12
 - DFE32B/UOH11B gateway*18
 - Installing and removing an option card*14
 - Auto setup for gateway operation43
- B**
- Baud rate 17, 126
 - Parameters for SBus*112
 - Bus cables
 - Shielding and routing*21
 - BUS FAULT LED26
- C**
- CAN
 - Starting up the USB-CAN interface*107
 - Communication
 - Configuring the communication via SBus* ...109
 - Parameters for SBus*112
 - Communication channel
 - Configuration*117
 - Configuring the serial communication*104
 - Communication connections
 - Configuring the communication channel*117
 - Configuring the serial communication*104
 - Communication type
 - Configuring the communication channel*117
 - Configuring the serial communication*104
 - Configuration
 - Communication channel*117
 - Configuring the serial communication*104
 - SBus communication*109
 - Connection
 - DFE32B option*19
 - MOVIDRIVE® B/MOVITRAC® B*20
 - System bus (SBus 1) between a MOVITRAC® B unit and DFE32B*15
 - System bus (SBus 1) between several MOVITRAC® B*16
 - Connection technology126
 - Control
 - MOVIDRIVE® MDX61B*56
 - MOVITRAC® B*58
 - Control example57
 - MOVIDRIVE® B unit replacement*25
 - MOVITRAC® B/gateway unit replacement* ...25
 - Copyright 7
- D**
- Designated use 96
 - DFE32B
 - Connection* 19
 - Operating display* 26
 - Terminal description* 19
 - Diagnostics 11, 122
 - PROFINET topology* 68
- E**
- Embedded safety notes 6
 - Error diagnostics 122
 - Error list in gateway operation 125
 - Establishing communication with other units 96
 - Exclusion of liability 7
 - Executing functions with the units 96, 120
- F**
- Fieldbus monitor 11
- G**
- Gateway operation, error list 125
 - General information 6
 - Copyright* 7
 - How to use the manual* 6
 - General notes
 - Exclusion of liability* 7
 - Right to claim under warranty* 7
- H**
- Homepage layout 90
- I**
- Interface adapter
 - USB11A, startup* 101
 - IP address 22
- L**
- Link/Activity LED 27
- M**
- Monitoring functions 11
 - MOVIAXIS®
 - Starting up the USB-CAN interface* 107
- N**
- Network classes 22
 - Notes
 - Designation in the documentation* 6
- O**
- Operating behavior 52
 - Communication model* 53
 - Process data configuration* 55
 - Three communication classes* 52
 - Three unit classes* 52



Unit model	53	PROFINET connection for MOVITRAC® B .	31, 37
Operating display DFE32B	26	Project planning with PROFINET	
BUS FAULT LED	26	Project planning for the PROFINET IO	
Link/Activity LED	27	controller	28
RUN LED	26	Protocol options	126
Option card		R	
Installation and removal	14	Resetting the IP address parameters	24
Other applicable documentation	8	Right to claim under warranty	7
P		RUN LED	26
Parameterization via PROFIdrive Data Set 47 ...	71	S	
Addressing connected inverters	76	Safety notes	8
Error codes of the PROFINET services	88	Designation in the documentation	6
Introducing PROFINET data sets	71	General safety notes for bus systems	8
PROFIdrive parameter requests	82	Hoist applications	8
Structure of the PROFINET parameter		Structure of the embedded safety notes	6
channel	73	Structure of the section-related safety notes .	6
Parameterization via PROFIdrive data set 47	74	Sample program	
Controller processing sequence	75	SIMATIC S7	60, 87
MOVILINK® parameter requests	77	SBus	
Read/write parameters	87	Timeout	59
Sample program for SIMATIC S7	87	Section-related safety notes	6
Technical data, PROFINET for		Setting	
MOVIDRIVE® DFE32B	87	MOVIDRIVE® MDX61B	45
Parameterization via PROFIdrive dataset 47		MOVITRAC® B	46
Features of the SEW-EURODRIVE		Setting the IP address parameters via DCP	24
PROFINET devices	72	Initial startup	24
Parameters		Signal words in the safety notes	6
Configuring the communication channel ...	117	SIMATIC S7	57
Configuring the communication via SBus ...	109	Sample program	60, 87
Configuring the serial communication	104	Standard gateway	23
Parameterizing units in the parameter tree	120	Starting up USB11A	101
Reading/changing unit parameters	120	Startup	
SBus	112	Starting up units	121
SMLP	119	Startup procedure for MDX61B with DFE32B	
Part number	126	Starting up MOVIDRIVE® B with	
Peak		DC 24 V or AC 400 V	47
Starting up the USB-CAN interface	107	Startup procedure for MDX61B with	
Pin assignment of an RJ45 plug connector	20	DFE32B option	47
Plug-in window	92	Preliminary work	47
Sample plug-in, bus monitor for		Startup procedure for the DFE32B option	
MOVIDRIVE®	93	as gateway	49
Sample plug-in, bus monitor for		Preliminary work	49
MOVITRAC®	94	Starting up units with DC 24 V or AC 400 V	50
Port statistics		Structure of the diagnostics applet	91
PROFINET topology	69	Subnet mask	22
Process data configuration	55	T	
Permitted configurations	55	TCP/IP addressing and subnetworks	22
PROFINET		IP address	22
Timeout	57	Standard gateway	23
Topology detection	63	Subnet mask	22
PROFINET LEDs	26	Technical data DFE32B	126
Project planning		Terminal description	
PROFINET topology	64	DFE32B option	19
Project planning for the PROFINET IO controller		Timeout	
Assigning the PROFINET device name	29	PROFINET	57
Installing the GSD file	28		



<i>SBus</i>	59
Topology detection	65
<i>PROFINET</i>	63
Topology editor	65

U

Unit replacement	25
USB-CAN interface	
<i>Startup</i>	107

W

Web server	89
<i>Access protection</i>	95
<i>Homepage layout</i>	90
<i>Plug-in window</i>	92
<i>Security settings</i>	89
<i>Software requirements</i>	89
<i>Structure of the diagnostics applet</i>	91

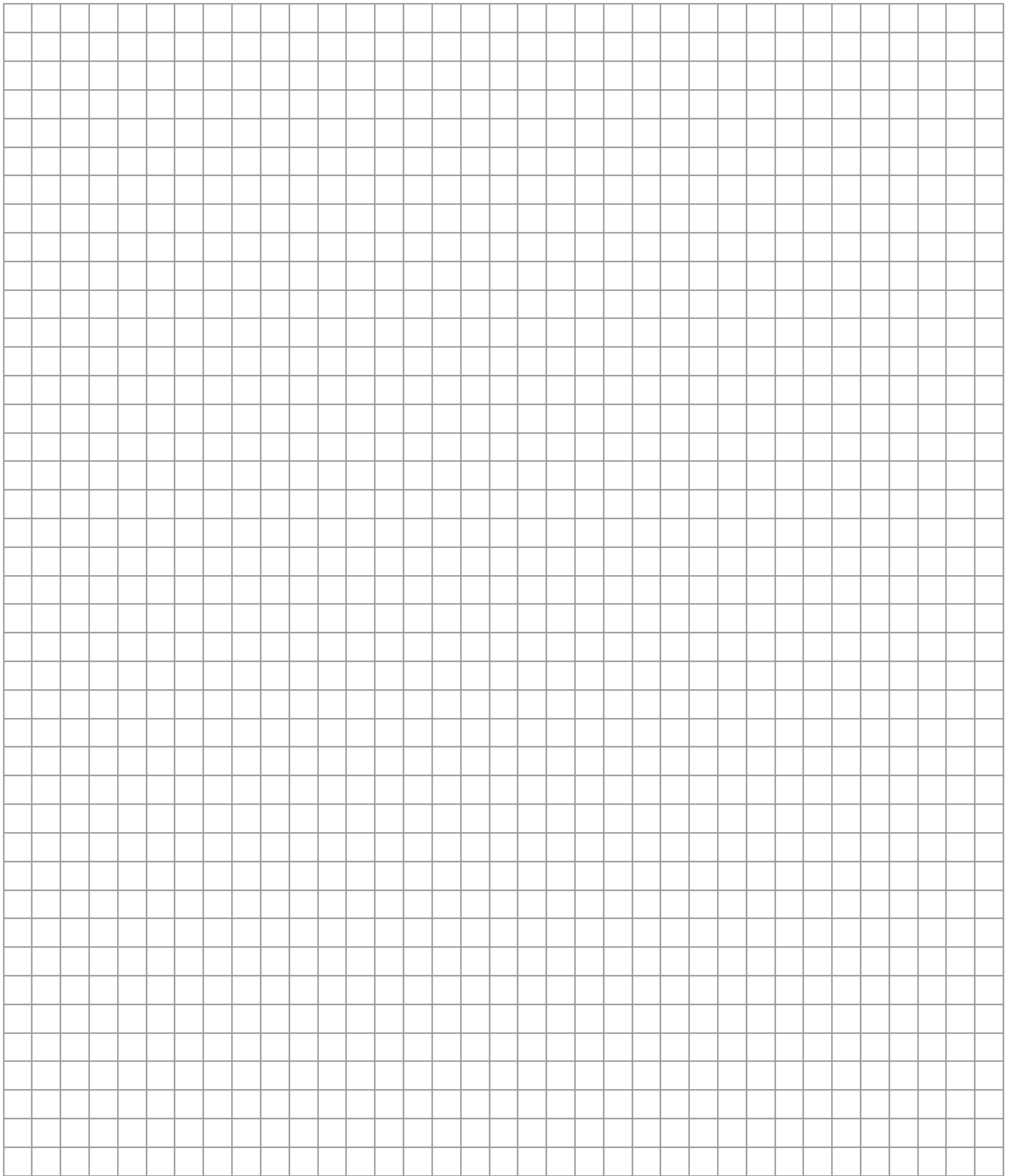



SEW-EURODRIVE
Driving the world

SEW
EURODRIVE

SEW-EURODRIVE GmbH & Co KG
P.O. Box 3023
D-76642 Bruchsal/Germany
Phone +49 7251 75-0
Fax +49 7251 75-1970
sew@sew-eurodrive.com

→ www.sew-eurodrive.com