

MOVITRAC® 31C Frequency Inverters

Addendum to the Operating Instructions FKB01 Heat Sink for Brake Resistors in Flatpack Design

Edition 10/96

- This addendum is not a replacement for the detailed operating instructions!
- Installation should only be performed by qualified electrical personnel in compliance with applicable accident prevention regulations and the MOVITRAC® 31C Operating Instructions!



FKB01 Heat Sink for Brake Resistors in Flatpack Design

(Part Number 813 099 X)

With the FKB01 heat sink, brake resistors BW 200-003 / BW 100-003 / BW 200-005 / BW100-005/ BW 047-005 (in flatpack design) can be mounted below MOVITRAC 31C sizes 1 and 2 conserving space.

The resistors are mounted in the heat sink and secured with the screws provided.

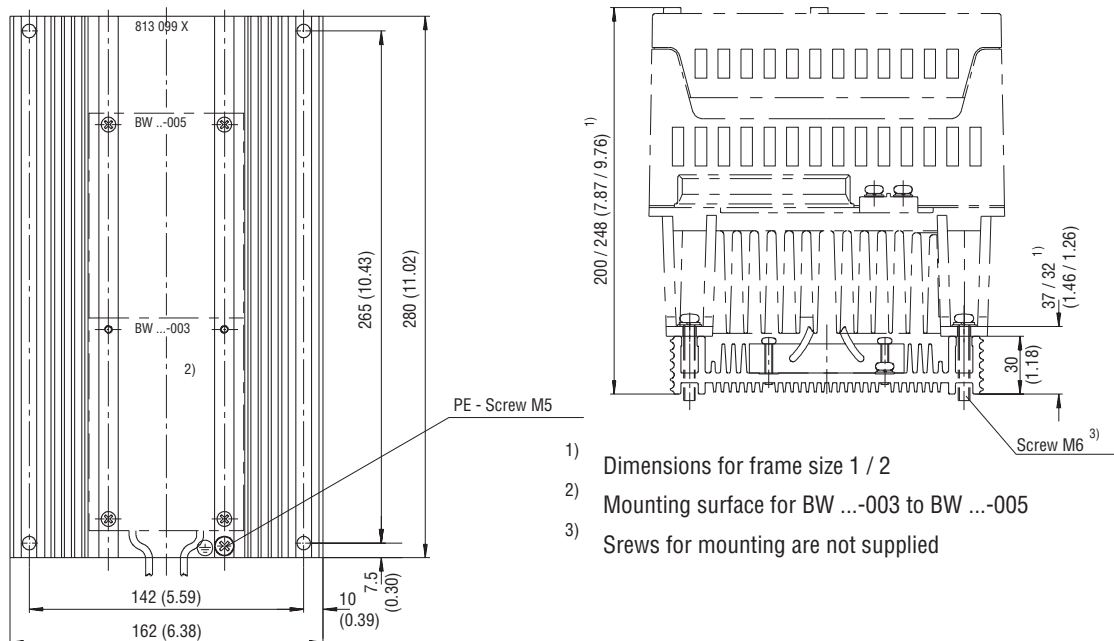

Fig. 1: FKB01 Heat sink for brake resistors in flatpack design, dimensions in mm (in)

00668AEN